



Public Works Department – Engineering Division

February 9, 2024

ADDENDUM NO. 2

PROJECT 2019 BART PEDESTRIAN AND BIKE CONNECTIVITY

NOTICE TO BIDDERS:

The following clarifications, amendments, additions and/or deletions as set forth herein shall apply to the above project contract documents and shall be made a part thereof and shall be subject to all the requirements thereof as though originally specified and/or shown. Submitters shall assure themselves that all addendum changes have been incorporated into their proposal.

A. ADDITIONS/DELETIONS

1. **Replace** the Bid Schedule – Attachment A
2. **Replace** the following Plans/Specifications:
 - a. See Revised Sheets I-5 to I-6
 - b. City Standard Details for Water and Irrigation.

B. CLARIFICATIONS

1. Please provide an estimated square footage for 'Grind Concrete' area required so bidders are apples to apples?

Bid Item #80 Grind Concrete quantity and unit has been revised to 500 SF. See Revised Bid Schedule, Attachment A.

2. There is no concrete cap bid item. The specs call for this item to be paid by the LF.?? The contract price paid per linear foot for Concrete Cap shall include full compensation for furnishing all labor, materials, tools, equipment and incidentals required to install the concrete cap over the existing pipe complete in place, including potholing, saw cutting, excavation, backfill, minor concrete cap, reinforcing, and temporary HMA paving as shown on the plans, as specified in the Standard Specifications and these technical provisions, and as directed by the Engineer.?? Please confirm that this work is not part of the contract or add a new bid item for this scope of work.

This work is not part of the contract.

-
- The measurement and payment sections for DG, asphalt paving and minor concrete items all include aggregate base.?? Please clarify if all aggregate base for DG, asphalt paving, sidewalk, and curb and gutter is to be measured and paid for by bid items 21, 79, and 145?

Bid Item# 22 is for the AB underneath the roadway AC on California Avenue, Bid Item# 24 is for the AB underneath the trail AC on California Avenue, Bid Item #88 is for the AB underneath the Bliss Avenue Path AC, and Bid item #161 is for AB underneath the Railroad Avenue Path AC. Sidewalk and curb and gutter shall be paid for by its respective bid item.

- There is no bid item for the wayfinding sign called out on Bliss Ave and method of payment.?? Please confirm how this item is to be paid for.

Bid Item # 129, Wayfinding Sign-Bliss Ave has been added. See Revised Bid Schedule, Attachment A.

- There are 3 inlets called out to be removed on California Ave and no method of payment.?? Please confirm how these are paid for.

Bid Item #69 – Remove Storm Drain Inlet, has been added. See Revised Bid Schedule, Attachment A.

- There is a tree called out to be removed on Bliss Ave and no method of payment.?? Please confirm how this is to be paid for.

This item shall be paid for under Bid Item #73, Clearing and Grubbing. See Revised Bid Schedule, Attachment A.

- Please provide a budget for each alternate. If the bidding amount exceed the budget, will the City reject the alternates?

The engineers estimate for the project is approximately \$5 Million. The current bid shall be awarded based on the lowest bidder for the total base bid plus bid alternate No.1. The City will award any alternates if budget allows.

- Referring to sheets L-1 through L-4, I-5 and I-6, it looks there are proposed planting areas along the new trail at California Avenue that are missing. Please clarify.

See revised Sheets I-5 and I-6 for planting and L-1 through L-4 for notes, legend, or abbreviation.

- Detail I-4/ sheet 2 of 3 on sheet I-8 shows all cables and electrical wires must be run in conduit. Please clarify if conduit is only needed at controller locations or it is needed for all 2-wire cables run from controller to remote control valves.

Bidders shall assume that it is necessary for all 2-wire cables run from controller to remote control valves See attached updated City Standard Details for water and irrigation – Attachment B

10. Detail I-4/ sheet 3 of 3 on sheet I-8 shows antenna. Please provide a location, model number and detail of antenna for bidding purposes.

Location to be determined by City Engineer in the field. Bidder shall assume a distance of 100 LF. See attached updated City Standard Details for water and irrigation – Attachment B.

11. Referring to detail I-15 on sheet I-9, provide a requirement and detail for 2-4" perforated drain pipes and grates secured with 2 self-tapping screws.

See attached updated City Standard Details for water and irrigation – Attachment B.

12. Per Standard Specifications of the State of California, Department of Transportation ("Caltrans"), section 20-2.01B(7) shows that valve boxes must be precast concrete. However, according to sheets I-8 and I-9, irrigation details show that the valve box is Brooks plastic model. Please advise

See attached updated City Standard Details for water and irrigation – Attachment B.

13. Referring to sheets I-8 thru I-11 - Irrigation details, no detail shown for irrigation sleeve. Please provide for bidding purpose.

See attached updated City Standard Details for water and irrigation – Attachment B.

14. Referring to sheet I-8, detail I-2 shows sand bedding cover and under the pipes. However, note #3 in same detail & the irrigation notes #25 on sheet I-7 show backfill which is excavated from the trench. Please clarify.

See attached updated City Standard Details for water and irrigation – Attachment B.

15. Please provide the wire sleeve size for bidding purposes, as it isn't mentioned in the document.

Wire Sleeve size shall be 2 inches..

16. Referring to sheet I-4, Irrigation legend shows that the size of Superior master valve which is noted on plans. However, sheets I-1 thru I-6 do not show size of the master valve. Please advise.

Master valve shall be the same size as the main.

17. Referring to sheet I-4, Irrigation legend shows that the size of Wilkins pressure regulating valve which is noted on plans. However, sheets I-1 thru I-6 do not show size of the pressure regulating valve. Please advise.

Pressure regulating valve shall be the same size as the main.

18. Referring to sheet I-4, irrigation legend shows the model of flow sensor which is Creative Sensor Technology FSI-T10-001. However, on sheet I-8, detail I-5 shows the model is Data Industrial IR200. Please advise.

See attached updated City Standard Details for water and irrigation – Attachment B.

19. Referring to sheets I-8 thru I-11 - Irrigation details, no detail is shown for irrigation backflow preventer device. Please provide a detail.

See attached updated City Standard Details for water and irrigation – Attachment B.

20. Referring to sheet I-1, there is a note in the top left shows "Connect existing valves to two wire path and install rain master TW-d decoders in valve boxes". Please clarify the number of existing valves to receive new decoders.

Bidder shall assume 4 existing valves.

21. Referring to sheet I-1, there is a note near Delta De Anza trail shows "Adjust irrigation sprinklers at new pathway alignment", please clarify the number of existing sprinkler & pipes at those planters or provide an as-built plan for verification.

Bidder shall assume 10 sprinklers with piping interconnecting.

22. Referring to sheet I-1, there are some drip tubing crossing the existing planting area that remains (no new plants, no new mulch), which can easily damage existing plants. Please clarify how to repair the existing planting areas.

Bidder shall assume to repair to existing or better condition.

23. Referring to Irrigation legend on sheet I-4, "Schedule 80 and schedule 40 PVC solvent weld fittings" are shown for mainline. Please confirm schedule 40 fittings could be used for mainline

Bidders shall bid for Schedule 80 for mainline.

-
24. According to sheets I-5 and I-6, there are eight remote control valves along California Avenue that are located on the mainline from basin with controller D (sheet I-4) but labeled "C". Please clarify if these valves should be named "D" and wires routed to controller D at the basin.

Correct. The valves shall be D.

25. Referring to the Bid Schedule, the unit LF is used for item #42 storm drain cleanout for bioretention strip. It is supposed to be EA. Please advise.

Correct. Bid Item #42, Storm Drain Cleanout For Bioretention Strip, has been revised to Bid Item #46, Storm Drain Cleanout For Bioretention Strip, 13 EA. See Revised Bid Schedule, Attachment A.

26. Referring to sheets L-1, L-2 & L-3, there are callouts #9 & 10 – 4-inch & 6-inch Irrigation sleeve (note 4). However, note 4 is "See sheets PD-1 & PD-2 for proposed striping and signage". Please clarify.

Disregard reference to Note 4 relating to the callout.

27. Referring to sheets L-8 & L-9, there are callouts #9 & 10 – 4-inch & 6-inch Irrigation sleeve (note 4). However, note 4 is not provided on these sheets. Please clarify.

Disregard reference to Note 4 relating to the callout.

28. Sheets L-5 thru L-9 are missing the location and limit of decomposed granite shoulder. Please advise.

See typical proposed section D on Sheet X-2 for stationing.

29. Sheets L-1, L-2, and L-3 are missing the location and limit of the bioretention strip. Please clarify.

See typical proposed section B on Sheet X-1. The bioretention strip is approximately from STA. 52+50 to STA.67+50.

30. Bid item 17 "Bioretention Basin Excavation" is a final quantity of 373 cy. Bid Items 43, 44, 48, & 49 add up to 458 cy. Shouldn't the excavation at minimum equal to the material going in plus any additional excavation need for the freeboard.

Bid Item #17, Bioretention Basin Excavation (F), has been revised to 650 CY.

Bid Item #18, Bioretention Strip Excavation (F) 458 CY, has been added.

Bid Item #44 Class 2 Permeable Material For Bioretention Strip has been renumbered to Bid Item #45, and quantity has been revised to 183 CY.

Bid Item #45, Bioretention Soil For Bioretention Basin, 137 CY has been revised to Bid Item #48, Bioretention Soil For Bioretention Strip, 275 CY.

Bid Item #49, Class 2 Permeable Material For Bioretention Basin At Harbor/California, 92 CY has been revised to Bid Item #52, Class 2 Permeable Material For Bioretention Basin At Harbor/California, 474 CY.

Bid Item #50, Bioretention Soil For Corner Basin At Harbor/California, 137 Cy Has Been Revised To Bid Item #53, Bioretention Soil For Corner Basin At Harbor/California, 711 CY.

See Revised Bid Schedule, Attachment A.

31. Plan sheet 36 calls for one Type OS Inlet. Can you provide bid item for this inlet.

Bid Item #37, Drainage Inlet (Type OS), 1 EA, has been added. See Revised Bid Schedule, Attachment A.

32. Asphalt demolition limits do not match new asphalt roadway limits.

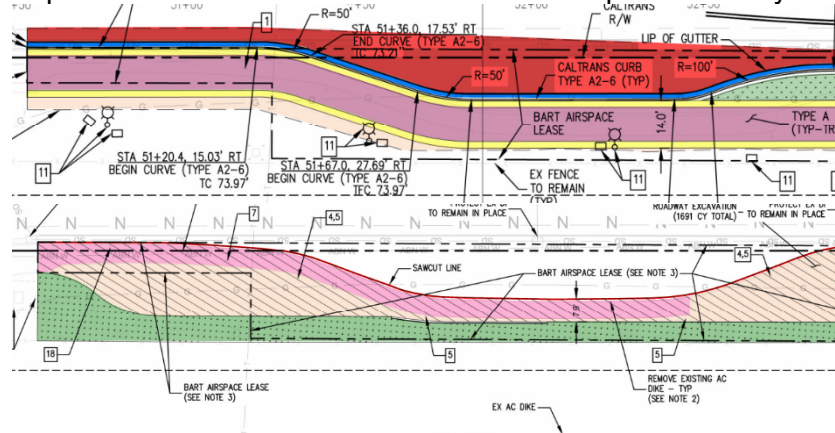

Demolition Limits have been revised. See below.

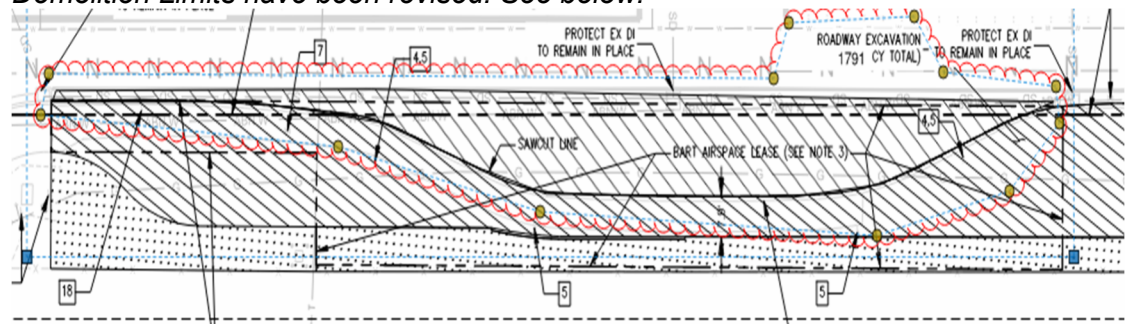

Bid Item #16 Roadway Excavation quantity has been revised to 1791 CY. See Revised Bid Schedule, Attachment A.

33. Please clarify if the 6" Perforated Pipe will be paid under bid item 92?

Bid Item #100 6" PVC Pipe (Non-Perforated) Quantity Has Been Revised To 55 LF. Bid Item #95 6" PVC Pipe (Perforated) has been revised to Bid Item #101 6" Pvc Pipe (Perforated) and the quantity has been revised To 50 LF. See Revised Bid Schedule, Attachment A.

34. Are the cleanouts part of bid item 113?

Correct. Cleanouts are included in this bid item.

35. I have a question about your paid items at the RAILROAD AVE (NORTH OF CALIFORNIA AVE) I notice you have bid items for White and Yellow Thermoplastic Pavement Markings, but I don't see a paid Item for the Green Bike Lane Markings. Please refer to PD-3.

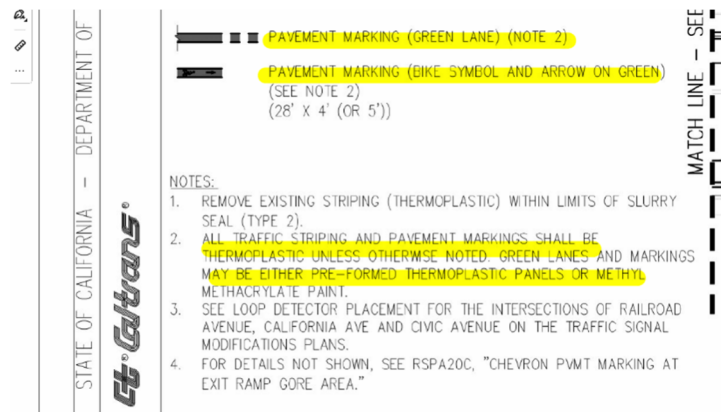

Bid Item #43, Pavement Marking (Green Bike Lanes) 350 SF, has been added. See Revised Bid Schedule, Attachment A.

36. Item #15 is the same item description as #59, is this correct or should one of the description something else?

Bid Item #15 Traffic Stripe (4" Yellow, Thermoplastic) 1816 LF has been removed. Bid Item #59 Traffic Stripe (4" Yellow, Thermoplastic) has been revised to Bid Item #64 Traffic Stripe (4" Yellow) Two Coat Paint. See Revised Bid Schedule, Attachment A.

37. Specification 51-4.02B indicates "The security wall panels shall be handled vertically at all time". It is cost prohibitive to Precast and Ship 8 to 10ft max tall

panels vertically. Please confirm if it acceptable to cast and ship these panels horizontally (eg. Flat).

The wall panels shall be handled in such a way that does not damage the final product for installation as shown on the contract documentation. If the panels are handled horizontally, it is the responsibility of the contractor to make sure the final product meets inspection.

38. *Bid Item #129, Bicycle Detector Symbol, has been revised to Bid Item #145, Bicycle/Arrow Detector Symbol. See Revised Bid Schedule, Attachment A.*

39. *Change from Addendum No 1: Bid Items #22 to Bid Item#25 have been revised to show the following:*

22	CLASS 2 AGGREGATE BASE (ROADWAY)	220	CY	\$	\$
23	TYPE A HOT MIX ASPHALT (ROADWAY)	324	TON	\$	\$
24	CLASS 2 AGGREGATE BASE (TRAIL)	700	CY	\$	\$
25	TYPE A HOT MIX ASPHALT (TRAIL)	1,355	TON	\$	\$

40. *Bid Item #63 LF – 4” Black Vinyl Chain Link Fence (CL-4) and Bid Item #64 -EA 10” Wide Black Vinyl Chain Link Access Gate (CL-4) have been revised to Bid Item #67 LF – 4” Black Vinyl Chain Link Fence (CL-4) and Bid Item #68 -EA 10” Wide Black Vinyl Chain Link Access Gate (CL-4). See Revised Bid Schedule, Attachment A.*

41. *There are no special permits/fees/inspections/requirements required with relation to PGE along California Avenue besides the lighting/work.*

42. *The project will not need Builder’s Risk Insurance.*

43. *The engineer's estimate is based on base bid and additional alternates A through E.*

44. *The lowest bid will be determined by combining the Base Bid plus Bid Alternate A only.*

BIDDERS MUST SIGN AND ATTACH one (1) copy of this addendum document to the proposal as acknowledgment of receipt of these instructions and that said addendum was properly evaluated in the proposal.

ANY PROPOSAL NOT IN COMPLIANCE WITH THIS ADDENDUM MAY BE REJECTED.



Issued: 02/09/24

Dayne Johnson, P.E.
Assistant City Engineer

ADDENDUM NO. 2, PROJECT 2019 BART PEDESTRIAN AND BIKE CONNECTIVITY is hereby acknowledged and was considered in this Project Proposal.

Bidder's Signature

Date

Firm Name

Mailing Address

City/State/Zip+4

Bid Schedule

This Bid Schedule must be completed in ink and included with the sealed Bid Proposal. Pricing must be provided for each Bid Item as indicated. Items marked "(SW)" are Specialty Work that must be performed by a qualified Subcontractor. The lump sum or unit cost for each item must be inclusive of all costs, whether direct or indirect, including profit and overhead. The sum of all amounts entered in the "Extended Total Amount" column must be identical to the Base Bid price entered in Section 1 of the Bid Proposal form

AL = Allowance CF = Cubic Feet CY = Cubic Yard EA = Each LB = Pounds
 LF = Linear Foot LS = Lump Sum SF = Square Feet TON = Ton (2000 lbs)

BID ITEM NO.	ITEM DESCRIPTION	EST. QTY.	UNIT	UNIT COST	EXTENDED TOTAL AMOUNT
1	MOBILIZATION	1	LS	\$	\$
2	TRAFFIC CONTROL SYSTEM	1	LS	\$	\$
3	CONSTRUCTION AREA SIGNS	22	EA	\$	\$
4	PROJECT FUNDING SIGN	2	EA	\$	\$
5	PROJECT INFORMATION SIGN	4	EA	\$	\$
6	LEAD COMPLIANCE PLAN	1	LS	\$	\$
7	STORMWATER POLLUTION PREVENTION PLAN (SWPPP)	1	LS	\$	\$
8	LANDSCAPE MAINTENANCE	1	LS	\$	\$
BASE BID - LOCATION: CALIFORNIA AVENUE					
9	TEMPORARY STORM DRAIN INLET PROTECTION	3	EA	\$	\$
10	CLEARING AND GRUBBING	1	LS	\$	\$
11	LAYOUT	1	LS	\$	\$
12	EXCAVATION SAFETY	1	LS	\$	\$
13	REMOVE STUMP	4	EA	\$	\$
14	REMOVE TREE	1	EA	\$	\$
15	REMOVE TRAFFIC STRIPING	20	LF	\$	\$
16	ROADWAY EXCAVATION (F)	1,791	CY	\$	\$
17	BIORETENTION BASIN EXCAVATION (F)	650	CY	\$	\$
18	BIORETENTION STRIP EXCAVATION (F)	458	CY	\$	\$
19	REMOVE CONCRETE	1,085	SF	\$	\$
20	REMOVE CURB AND GUTTER	158	LF	\$	\$
21	ADJUST WATER VALVE COVER TO GRADE (NP)	5	EA	\$	\$
22	CLASS 2 AGGREGATE BASE (ROADWAY)	220	CY	\$	\$
23	TYPE A HOT MIX ASPHALT (ROADWAY)	324	TON	\$	\$
24	CLASS 2 AGGREGATE BASE (TRAIL)	700	CY	\$	\$

BID ITEM NO.	ITEM DESCRIPTION	EST. QTY.	UNIT	UNIT COST	EXTENDED TOTAL AMOUNT
25	TYPE A HOT MIX ASPHALT (TRAIL)	1,355	TON	\$	\$
26	DECOMPOSED GRANITE	270	CY	\$	\$
27	CURB (TYPE A2-6)	225	LF	\$	\$
28	CURB (TYPE A2-6) (SEGMENTED 12" OPENING)	1,600	LF	\$	\$
29	SIDEWALK	1,375	SF	\$	\$
30	CURB RAMP	3	EA	\$	\$
31	REMOVE 18" STORM DRAIN PIPE	126	LF	\$	\$
32	ABANDON 12" STORM DRAIN PIPE	67	LF	\$	\$
33	12" RCP PIPE	547	LF	\$	\$
34	18" RCP PIPE	156	LF	\$	\$
35	DRAINAGE INLET (TYPE G1)	4	EA	\$	\$
36	DRAINAGE INLET (TYPE G3)	3	EA	\$	\$
37	DRAINAGE INLET (TYPE OS)	1	EA	\$	\$
38	REMODEL DI WITH MH TOP	2	EA	\$	\$
39	REMOVE ROADSIDE SIGN	10	EA	\$	\$
40	REMOVE ROADSIDE SIGN (PG&E GAS MARKER)	5	EA	\$	\$
41	RELOCATE ROADSIDE SIGN	5	EA	\$	\$
42	REMOVE ROADSIDE SIGN PANEL ("TOW ZONE NO PARKING")	2	EA	\$	\$
43	ROADSIDE SIGN PANEL	1	EA	\$	\$
44	ROADSIDE SIGN	10	EA	\$	\$
45	6" PVC PIPE (PERFORATED) FOR BIORETENTION STRIP	2,050	LF	\$	\$
46	STORM DRAIN CLEANOUT FOR BIORETENTION STRIP	13	EA	\$	\$
47	CLASS 2 PERMEABLE MATERIAL FOR BIORETENTION STRIP	183	CY	\$	\$
48	BIORETENTION SOIL FOR BIORETENTION STRIP	275	CY	\$	\$
49	4" PVC PIPE (PERFORATED & SOLID) FOR BIORETENTION BASIN	155	LF	\$	\$
50	STORM DRAIN CLEANOUT FOR BIORETENTION BASIN AT HARBOR/CALIFORNIA	2	EA	\$	\$
51	ENERGY DISSIPATOR FOR BIORETENTION BASIN AT HARBOR/CALIFORNIA	1	LS	\$	\$
52	CLASS 2 PERMEABLE MATERIAL FOR BIORETENTION BASIN AT HARBOR/CALIFORNIA	474	CY	\$	\$
53	BIORETENTION SOIL FOR CORNER BASIN AT HARBOR/CALIFORNIA	711	CY	\$	\$
54	SOIL PREPARATION	2,875	SF	\$	\$

BID ITEM NO.	ITEM DESCRIPTION	EST. QTY.	UNIT	UNIT COST	EXTENDED TOTAL AMOUNT
55	STONE MULCH	29	CY	\$	\$
56	WOOD MULCH	110	CY	\$	\$
57	TREES, FIFTEEN GALLON CONTAINER PLANT	5	EA	\$	\$
58	ONE GALLON CONTAINER PLANT (BIORETENTION BASIN)	668	EA	\$	\$
59	ONE GALLON CONTAINER PLANT (BIORETENTION STRIP)	980	EA	\$	\$
60	IRRIGATION SYSTEM	1	LS	\$	\$
61	TRAFFIC STRIPE (DETAIL 9) THERMOPLASTIC	1,342	LF	\$	\$
62	TRAFFIC STRIPE (DETAIL 22) THERMOPLASTIC	1,587	LF	\$	\$
63	TRAFFIC STRIPE (DETAIL 38) THERMOPLASTIC	149	LF	\$	\$
64	TRAFFIC STRIPE (4" YELLOW) TWO COAT PAINT	1,853	LF	\$	\$
65	TRAFFIC STRIPE (TYPE IV ARROW) THERMOPLASTIC	2	EA	\$	\$
66	HEADERBOARD	3,750	LF	\$	\$
67	4" BLACK VINYL CHAIN LINK FENCE (CL-4)	157	LF	\$	\$
68	10" WIDE BLACK VINYL CHAIN LINK ACCESS GATE (CL-4)	1	EA	\$	\$
69	REMOVE STORM DRAIN INLET	3	EA	\$	\$
BASE BID - LOCATION: BLISS AVENUE PATH					
70	TEMPORARY STORM DRAIN INLET PROTECTION	11	EA	\$	\$
71	LAYOUT	1	LS	\$	\$
72	TESTING & RESTORATION OF EXISTING IRRIGATION FACILITIES	1	LS	\$	\$
73	CLEARING AND GRUBBING	1	LS	\$	\$
74	ROADWAY EXCAVATION (F)	280	CY	\$	\$
75	REMOVE CONCRETE	993	SF	\$	\$
76	REMOVE CURB AND GUTTER	42	LF	\$	\$
77	RECONSTRUCT CHAIN LINK FENCE (CL-6)	172	LF	\$	\$
78	RELOCATE FENCE (CL-6)	35	LF	\$	\$
79	REMOVE PERFORATED PIPE	19	LF	\$	\$
80	GRIND CONCRETE	500	SF	\$	\$
81	ADJUST SD CLEANOUT COVER TO GRADE	1	EA	\$	\$
82	ADJUST IRRIGATION VALVE COVER TO GRADE (SERVICE)	1	EA	\$	\$
83	ADJUST IRRIGATION PULL BOX TO GRADE (SERVICE)	6	EA	\$	\$

BID ITEM NO.	ITEM DESCRIPTION	EST. QTY.	UNIT	UNIT COST	EXTENDED TOTAL AMOUNT
84	RELOCATE IRRIGATION VALVE AND COVER (SERVICE)	1	EA	\$	\$
85	RECONSTRUCT DRAINAGE INLET TOP TO GRADE	1	EA	\$	\$
86	ADA GRATE	5	EA	\$	\$
87	TRASH CAPTURE DEVICE	10	EA	\$	\$
88	CLASS 2 AGGREGATE BASE	116	CY	\$	\$
89	TYPE A HOT MIX ASPHALT	92	TON	\$	\$
90	DECOMPOSED GRANITE	31	CY	\$	\$
91	CURB (TYPE A2-6)	42	LF	\$	\$
92	SIDEWALK	3,645	SF	\$	\$
93	CURB RAMP	2	EA	\$	\$
94	DETECTABLE WARNING SURFACE IN CONCRETE PAD	68	SF	\$	\$
95	CHAIN LINK FENCE (CL-6, MODIFIED)	961	LF	\$	\$
96	4' WIDE CHAIN LINK WALK GATE (CL-6, MODIFIED)	2	EA	\$	\$
97	12" RCP PIPE	30	LF	\$	\$
98	15" RCP PIPE	42	LF	\$	\$
99	30" RCP PIPE	10	LF	\$	\$
100	6" PVC PIPE (NON-PERFORATED)	55	LF	\$	\$
101	6" PVC PIPE (PERFORATED)	50	LF	\$	\$
102	DRAINAGE INLET (TYPE G1)	6	EA	\$	\$
103	DRAINAGE INLET (TYPE G1 MODIFIED)	1	EA	\$	\$
104	FIELD INLET (2' SQUARE)	1	EA	\$	\$
105	BLIND CONNECTION (STORM DRAIN)	1	EA	\$	\$
106	BOLLARD	2	EA	\$	\$
107	REMOVABLE BOLLARD	1	EA	\$	\$
108	ROADSIDE SIGN	1	EA	\$	\$
109	RELOCATE ROADSIDE SIGN	1	EA	\$	\$
110	SECURITY CAMERA SYSTEM ALONG BLISS AVE TRAIL (SHEET E-12)	1	LS	\$	\$
111	TRENCH AND BACKFILL (BLISS AVENUE LIGHTING)	1,670	LF	\$	\$
112	2" PVC CONDUIT (BLISS AVENUE LIGHTING)	1,670	LF	\$	\$
113	#8 AWG STRANDED COPPER CONDUCTOR (BLISS AVENUE LIGHTING)	3,260	LF	\$	\$
114	#8 AWG BARE SOLID CONDUCTOR (GROUND) (BLISS AVENUE LIGHTING)	1,630	LF	\$	\$

BID ITEM NO.	ITEM DESCRIPTION	EST. QTY.	UNIT	UNIT COST	EXTENDED TOTAL AMOUNT
115	#5 PULL BOX (BLISS AVENUE LIGHTING)	22	EA	\$	\$
116	INSTALL CONDUIT IN EXISTING PULL BOX (BLISS AVENUE LIGHTING)	1	EA	\$	\$
117	CIRCUIT BREAKER (BLISS AVENUE LIGHTING)	1	EA	\$	\$
118	CONTACTOR (BLISS AVENUE LIGHTING)	1	EA	\$	\$
119	LIGHT FIXTURE, POLE, AND FOUNDATION (BLISS AVENUE LIGHTING)	14	EA	\$	\$
120	#6 AWG STRANDED COPPER CONDUCTOR	1,000	LF	\$	\$
121	#6 AWG BARE SOLID CONDUCTOR	25	LF	\$	\$
122	#4 AWG STRANDED COPPER CONDUCTOR	200	LF	\$	\$
123	REMOVE PULL BOX	3	EA	\$	\$
124	SPLICE NEW TO EXISTING CONDUCTORS	5	EA	\$	\$
125	CONNECT NEW AND EXISTING CONDUIT	6	EA	\$	\$
126	WOOD MULCH	15	CY	\$	\$
127	MODIFY BIORETENTION BASIN (BART PARKING LOT)	1	LS	\$	\$
128	RESTORE IRRIGATION SYSTEM	1	LS	\$	\$
129	WAYFINDING SIGNAGE (BLISS AVE)	1	EA	\$	\$
BASE BID - LOCATION: RAILROAD AVENUE (NORTH OF CALIFORNIA AVENUE)					
130	TEMPORARY STORM DRAIN INLET PROTECTION	13	EA	\$	\$
131	REMOVE TRAFFIC STRIPING	1,696	LF	\$	\$
132	REMOVE PAVEMENT MARKING	2,500	SF	\$	\$
133	TRAFFIC STRIPE (DETAIL 9) (THERMOPLASTIC)	2,657	LF	\$	\$
134	TRAFFIC STRIPE (DETAIL 27B) (THERMOPLASTIC)	352	LF	\$	\$
135	TRAFFIC STRIPE (DETAIL 36) (THERMOPLASTIC)	320	LF	\$	\$
136	TRAFFIC STRIPE (DETAIL 38) (THERMOPLASTIC)	539	LF	\$	\$
137	TRAFFIC STRIPE (DETAIL 39) (THERMOPLASTIC)	4,210	LF	\$	\$
138	TRAFFIC STRIPE (DETAIL 39A) (THERMOPLASTIC)	280	LF	\$	\$
139	TRAFFIC STRIPE (DETAIL 40) (THERMOPLASTIC)	220	LF	\$	\$
140	TRAFFIC STRIPE (DETAIL 24) (THERMOPLASTIC)	2,600	LF	\$	\$
141	PAVEMENT MARKING (WHITE) (THERMOPLASTIC)	4,205	SF	\$	\$
142	PAVEMENT MARKING (YELLOW) (THERMOPLASTIC)	900	SF	\$	\$
143	PAVEMENT MARKING (GREEN BIKE LANES)	350	SF	\$	\$
144	ROADSIDE SIGN	15	EA	\$	\$
145	BICYCLE/ARROW DETECTOR SYMBOL	11	EA	\$	\$

BID ITEM NO.	ITEM DESCRIPTION	EST. QTY.	UNIT	UNIT COST	EXTENDED TOTAL AMOUNT
146	SLURRY SEAL (TYPE II)	15,220	SY	\$	\$
147	BLUE REFLECTIVE PAVEMENT MARKER	2	EA	\$	\$
BASE BID - LOCATION: RAILROAD AVENUE PATH					
148	TEMPORARY STORM DRAIN INLET PROTECTION	5	EA	\$	\$
149	TREE PROTECTION AND ROOT PRUNING	1	LS	\$	\$
150	LAYOUT	1	LS	\$	\$
151	CLEARING AND GRUBBING	1	LS	\$	\$
152	REMOVE STUMP	10	EA	\$	\$
153	REMOVE TREE	12	EA	\$	\$
154	REMOVE TRAFFIC STRIPING	414	LF	\$	\$
155	ROADWAY EXCAVATION (F)	322	CY	\$	\$
156	REMOVE CONCRETE	2,965	SF	\$	\$
157	REMOVE CURB AND GUTTER	343	LF	\$	\$
158	REMOVE BENCH	1	EA	\$	\$
159	ADJUST WATER VALVE COVER TO GRADE (NP)	1	EA	\$	\$
160	ADJUST WATER METER COVER TO GRADE (SERVICE)	2	EA	\$	\$
161	CLASS 2 AGGREGATE BASE	422	CY	\$	\$
162	TYPE A HOT MIX ASPHALT	349	TON	\$	\$
163	CURB (TYPE A1-6)	32	LF	\$	\$
164	CURB (TYPE A2-6)	343	LF	\$	\$
165	SIDEWALK	3,852	SF	\$	\$
166	DECOMPOSED GRANITE	69	CY	\$	\$
167	CURB RAMP	14	EA	\$	\$
168	ISLAND PASSAGEWAY	98	SF	\$	\$
169	BUS SHELTER AND FOUNDATION	1	LS	\$	\$
170	RELOCATE TRASH CAN	1	EA	\$	\$
171	RELOCATE ROADSIDE SIGN	3	EA	\$	\$
172	WAYFINDING SIGNAGE (BART)	1	EA	\$	\$
173	ROADSIDE SIGN	16	EA	\$	\$
174	PAVEMENT MARKING (WHITE) (THERMOPLASTIC) (CROSSWALK)	2,498	SF	\$	\$
175	WOOD MULCH	373	CY	\$	\$
176	TREES, FIFTEEN GALLON CONTAINER PLANT	40	EA	\$	\$
177	4" DIAMETER IRRIGATION CONDUIT	90	LF	\$	\$
178	6" DIAMETER IRRIGATION CONDUIT	250	LF	\$	\$
179	IRRIGATION SYSTEM	1	LS	\$	\$
180	HEADERBOARD	965	LF	\$	\$

BID ITEM NO.	ITEM DESCRIPTION	EST. QTY.	UNIT	UNIT COST	EXTENDED TOTAL AMOUNT
BASE BID - TRAFFIC SIGNAL IMPROVEMENTS					
181	TRAFFIC SIGNAL SYSTEM MODIFICATIONS @ RAILROAD AVE/ BLISS AVE (SHEET E-1 TO E-2)	1	LS	\$	\$
182	MODIFICATIONS TO TRAFFIC SIGNAL AND ELECTRICAL SYSTEMS @ RAILROAD AVE/ ROUTE 4 EB RAMPS (SHEET E-3 TO E-4)	1	LS	\$	\$
183	TRAFFIC SIGNAL SYSTEM MODIFICATIONS @ RAILROAD AVE/ CALIFORNIA AVE (SHEET E-5 TO E-6)	1	LS	\$	\$
184	TRAFFIC SIGNAL SYSTEM MODIFICATIONS @ RAILROAD AVE/ CIVIC AVE (SHEET E-7 TO E-8)	1	LS	\$	\$
185	MODIFICATIONS TO TRAFFIC SIGNAL AND ELECTRICAL SYSTEMS @ CALIFORNIA AVE/HARBOR ST (SHEET E-9)	1	LS	\$	\$
186	MODIFICATIONS TO TRAFFIC SIGNAL AND ELECTRICAL SYSTEMS @ RAILROAD AVE/ ROUTE 4 EB RAMPS (SHEET E-3 TO E-4)	1	LS	\$	\$
187	TRAFFIC SIGNAL SYSTEM MODIFICATIONS @ RAILROAD AVE/ CALIFORNIA AVE (SHEET E-5 TO E-6)	1	LS	\$	\$
188	TRAFFIC SIGNAL SYSTEM MODIFICATIONS @ RAILROAD AVE/ CIVIC AVE (SHEET E-7 TO E-8)	1	LS	\$	\$
189	MODIFICATIONS TO TRAFFIC SIGNAL AND ELECTRICAL SYSTEMS @ CALIFORNIA AVE/HARBOR ST (SHEET E-9)	1	LS	\$	\$
BASE BID TOTAL					
ALTERNATE BID A – CALIFORNIA AVE LIGHTING					
190	TRENCH AND BACKFILL (CALIFORNIA AVENUE LIGHTING)	2,750	LF	\$	\$
191	2" PVC CONDUIT (CALIFORNIA AVENUE LIGHTING)	2,600	LF	\$	\$
192	3" PVC CONDUIT (CALIFORNIA AVENUE LIGHTING)	150	LF	\$	\$
193	#8 AWG STRANDED COPPER CONDUCTOR (CALIFORNIA AVENUE LIGHTING)	10,250	LF	\$	\$
194	#6 AWG BARE SOLID CONDUCTOR (GROUND) (CALIFORNIA AVENUE LIGHTING)	2,000	LF	\$	\$
195	#5 PULL BOX (CALIFORNIA AVENUE LIGHTING)	29	EA	\$	\$
196	#3 1/2 PULL BOX (CALIFORNIA AVENUE LIGHTING)	3	EA	\$	\$
197	SERVICE CABINET AND FOUNDATION (CALIFORNIA AVENUE LIGHTING)	1	EA	\$	\$
198	SERVICE RISER (CALIFORNIA AVENUE LIGHTING)	1	EA	\$	\$
199	LIGHT FIXTURE, POLE, AND FOUNDATION (CALIFORNIA AVENUE LIGHTING)	25	EA	\$	\$
ALTERNATE BID A SUBTOTAL					\$

BID ITEM NO.	ITEM DESCRIPTION	EST. QTY.	UNIT	UNIT COST	EXTENDED TOTAL AMOUNT
ALTERNATE BID B – RAILROAD AVE SECURITY WALL					
200	CLEARING AND GRUBBING	1	LS	\$	\$
201	REMOVE TREE	3	EA	\$	\$
202	LAYOUT	1	LS	\$	\$
203	16" CAST-IN-DRILLED HOLE PILE (SECURITY WALL)	804	LF	\$	\$
204	FURNISH AND ERECT PRECAST SECURITY WALL - TYPE 1 (9')	198	LF	\$	\$
205	FURNISH AND ERECT PRECAST SECURITY WALL - TYPE 1 (10')	479	LF	\$	\$
206	FURNISH AND ERECT PRECAST SECURITY WALL - TYPE 2 (8')	90	LF	\$	\$
207	FURNISH AND ERECT PRECAST SECURITY WALL - TYPE 2 (9')	240	LF	\$	\$
208	CONNECTION TO EXISTING FENCE (8' STEEL FENCE)	15	LF	\$	\$
209	FIVE GALLON VINE CONTAINER PLANT	52	EA	\$	\$
210	IRRIGATION SYSTEM	1	LS	\$	\$
ALTERNATE BID B SUBTOTAL					\$
ALTERNATE BID C – RAILROAD AVENUE PATH PLANTING AND IRRIGATION					
211	SOIL PREPARATION	48410	SF	\$	\$
212	SOD	7658	SF	\$	\$
213	WOOD HEADER	150	LF	\$	\$
214	ONE GALLON CONTAINER PLANT	926	EA	\$	\$
215	IRRIGATION SYSTEM	1	LS	\$	\$
ALTERNATE BID C SUBTOTAL					\$
ALTERNATE BID D – RAILROAD AVENUE PATH LIGHTING					
216	TRENCH AND BACKFILL (RAILROAD AVENUE LIGHTING)	2300	LF	\$	\$
217	2" PVC CONDUIT (RAILROAD AVENUE LIGHTING)	2300	LF	\$	\$
218	#8 AWG STRANDED COPPER CONDUCTOR (RAILROAD AVENUE LIGHTING)	7650	LF	\$	\$
219	#8 AWG BARE SOLID CONDUCTOR (GROUND) (RAILROAD AVENUE LIGHTING)	2550	LF	\$	\$
220	#5 PULL BOX (RAILROAD AVENUE LIGHTING)	31	EA	\$	\$
221	#6 PULL BOX (RAILROAD AVENUE LIGHTING)	2	EA	\$	\$
222	INSTALL CONDUIT IN EXISTING PULL BOX (RAILROAD AVENUE LIGHTING)	1	EA	\$	\$
223	REMOVE PULL BOX (RAILROAD AVENUE LIGHTING)	1	EA	\$	\$
224	CIRCUIT BREAKER (RAILROAD AVENUE LIGHTING)	4	EA	\$	\$

BID ITEM NO.	ITEM DESCRIPTION	EST. QTY.	UNIT	UNIT COST	EXTENDED TOTAL AMOUNT
225	CONTACTOR (RAILROAD AVENUE LIGHTING)	4	EA	\$	\$
226	LIGHT FIXTURE, POLE, AND FOUNDATION (RAILROAD AVENUE LIGHTING)	33	EA	\$	\$
ALTERNATE BID D SUBTOTAL					\$
ALTERNATE BID E – CALIFORNIA AVE STREET LIGHTING					
227	TRENCH AND BACKFILL (CALIFORNIA AVENUE LIGHTING)	1,870	LF	\$	\$
228	2" PVC CONDUIT (CALIFORNIA AVENUE LIGHTING)	2,285	LF	\$	\$
229	3" PVC CONDUIT (CALIFORNIA AVENUE LIGHTING)	125	LF	\$	\$
230	#8 AWG STRANDED COPPER CONDUCTOR (CALIFORNIA AVENUE LIGHTING)	9,610	LF	\$	\$
231	#6 AWG BARE SOLID CONDUCTOR (GROUND) (CALIFORNIA AVENUE LIGHTING)	2,410	LF	\$	\$
232	#5 PULL BOX (CALIFORNIA AVENUE LIGHTING)	9	EA	\$	\$
233	#3 1/2 PULL BOX (CALIFORNIA AVENUE LIGHTING)	3	EA	\$	\$
234	#2 PULL PGE BOX (CALIFORNIA AVENUE LIGHTING)	1	EA	\$	\$
235	SERVICE CABINET AND FOUNDATION (CALIFORNIA AVENUE LIGHTING)	1	EA	\$	\$
236	SERVICE RISER (CALIFORNIA AVENUE LIGHTING)	1	EA	\$	\$
237	STREET FIXTURE, POLE, AND FOUNDATION (CALIFORNIA AVENUE LIGHTING)	6	EA	\$	\$
ALTERNATE BID E SUBTOTAL					\$
(F) Final Pay					
(NP) Non-Participating					

TOTAL BASE BID: Items 1 through 182 inclusive: \$ _____

TOTAL ALTERNATE BID A: Items 182 through 192 inclusive: \$ _____

TOTAL ALTERNATE BID B: Items 193 through 203 inclusive: \$ _____

TOTAL ALTERNATE BID C: Items 204 through 208 inclusive: \$ _____

TOTAL ALTERNATE BID D: Items 209 through 219 inclusive: \$ _____

TOTAL ALTERNATE BID E: Items 220 through 230 inclusive: \$ _____

Note: The amounts entered above should be identical to the amounts entered in Section 1 and 2 of the Bid Proposal form.

BIDDER NAME: _____

END OF BID SCHEDULE

WATER NOTES

1. SEE THE FOLLOWING DETAILS FOR WATER LINE CRITERIA: "CALIFORNIA REGULATIONS RELATED TO DRINKING WATER", TITLE 22, SECTION 64570
2. CRITERIA FOR THE SEPARATION OF WATER MAINS AND GRAVITY SANITARY SEWERS ARE PER THE CALIFORNIA DEPARTMENT OF PUBLIC HEALTH SERVICES STANDARDS.
3. THE "CALIFORNIA WATERWORKS STANDARDS" IS AVAILABLE ONLINE AT: WWW.WATERBOARDS.CA.GOV



APPROVED _____

3/8/23

DRAFT

DATE



CITY OF
PITTSBURG

NO.	DATE	REVISION	DRAWN BY:
1	2019-01-11	NOTE 3	
			CHECKED BY: MK
			DATE: 2019-01-11
			SCALE: NONE

STANDARD DETAIL

WATER NOTES

SHEET 1 OF 1

W-1

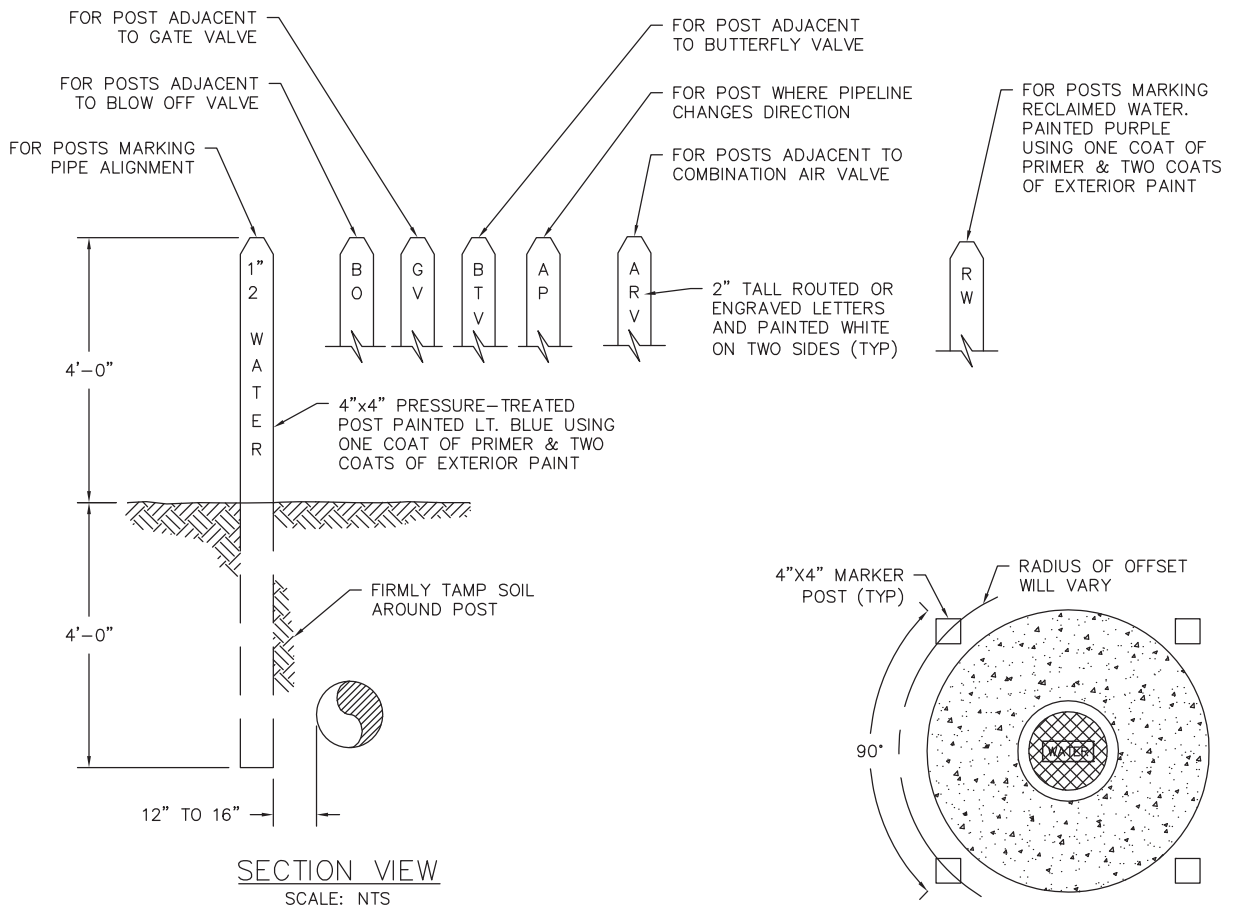

NOTES

1. WHERE THE NEW PIPELINE IS LOCATED OUTSIDE OF AN EXISTING STREET:
 - A. FOUR MARKER POSTS SHALL BE INSTALLED AT EACH APPURTENANCE (I.E. VALVE, BLOW OFF, ARV, ETC.). THE MARKER POSTS SHALL BE UNIFORMLY SPACED ON THE ARC OF A CIRCLE ABOUT THE APPURTENANCE.
 - B. A SINGLE MARKER POST SHALL BE INSTALLED AT 500' INTERVALS OR AT EACH POINT WHERE THERE IS A CHANGE IN HORIZONTAL DIRECTION.

APPROVED  DATE 3/8/23

DRAFT

 CITY OF PITTSBURGH	NO.	DATE	REVISION	DRAWN BY: BJR	STANDARD DETAIL MARKER POSTS	SHEET 1 OF 1 W-2
				CHECKED BY: MK		
				DATE: 2019-01-11		
				SCALE: NTS		

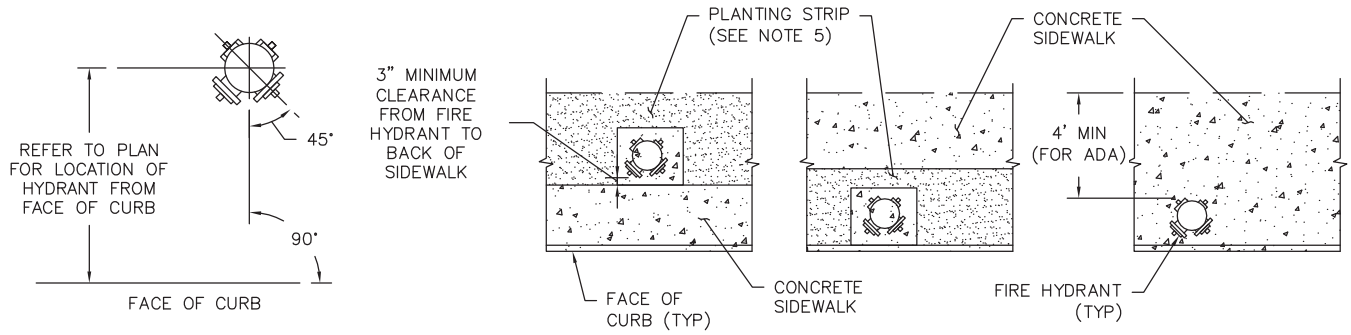

TYPICAL PLANS
SCALE: NTS

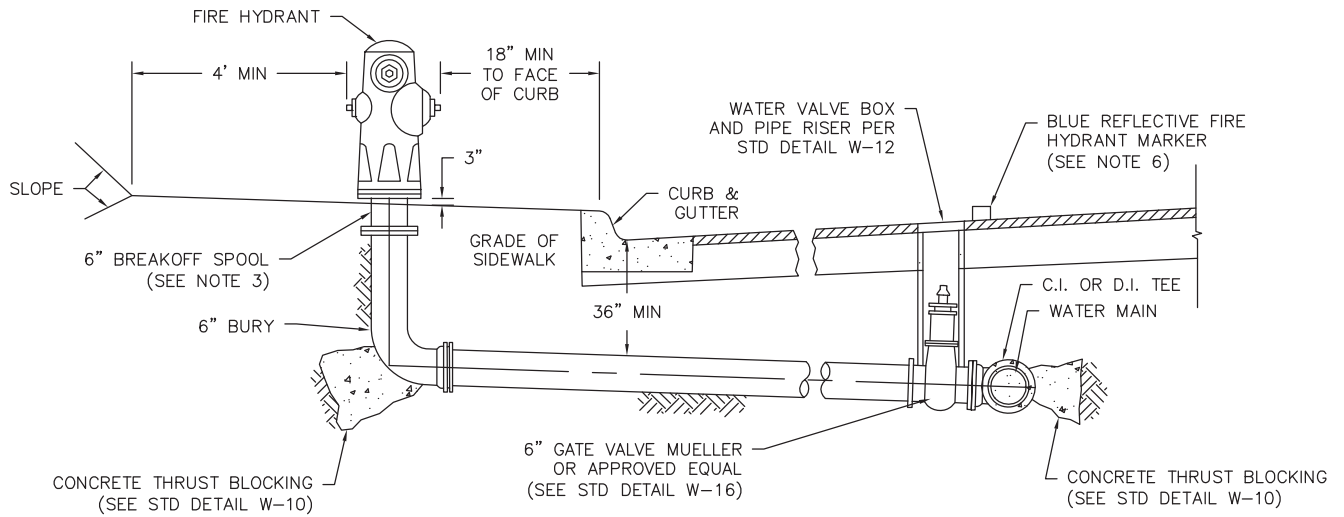

SECTION VIEW
SCALE: NTS

NOTES

1. ALL HOSE OUTLET CAPS SHALL BE ATTACHED TO HYDRANT BY CHAIN.
2. HYDRANT SHALL BE IN ACCORDANCE WITH AWWA STANDARDS, TESTED AND APPROVED BY UNDERWRITERS LABORATORIES, OR EQUIVALENT.
3. FIRE HYDRANT AND EXPOSED BREAKOFF SPOOL SHALL BE PAINTED WITH DUPONT 30-10 WHITE ENAMEL PRIMER, FOLLOWED WITH A FINISH COAT OF NO. 612-00 WHITE FULLER O'BRIEN HEAVY DUTY, HIGH GLOSS PAINT.
4. ALL FIRE HYDRANTS TO BE SAME MAKE THROUGHOUT SUBDIVISION.
5. HYDRANTS SHALL BE CENTERED ON 2' SQUARE, 4" THICK CONCRETE PAD WHEN PLACED IN LANDSCAPE OR PLANTING STRIP.
6. BLUE REFLECTIVE FIRE HYDRANT MARKER SHALL BE LOCATED PER CA MUTCD (LATEST EDITION) FIGURE 3B-102 (CA).

HOSE OUTLETS: (1) 2-1/2" NOZZLE (1) 4-1/2" NOZZLE	
MAKE	MODEL
CLOW	950
OR APPROVED EQUAL	

APPROVED  3/8/23
DATE

DRAFT

 CITY OF PITTSBURG	NO.	DATE	REVISION	DRAWN BY:	STANDARD DETAIL HYDRANT INSTALLATION – RESIDENTIAL	SHEET 1 OF 2 W-4
	1	2019-01-11	NOTES 5&6	BJR		
				CHECKED BY: MK		
				DATE: 2019-01-11		
				SCALE: NTS		

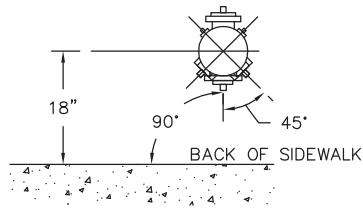

PLAN VIEW
SCALE: NTS

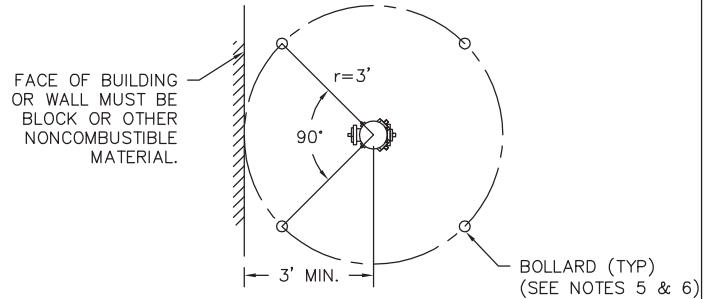

BOLLARD PLACEMENT
SCALE: NTS

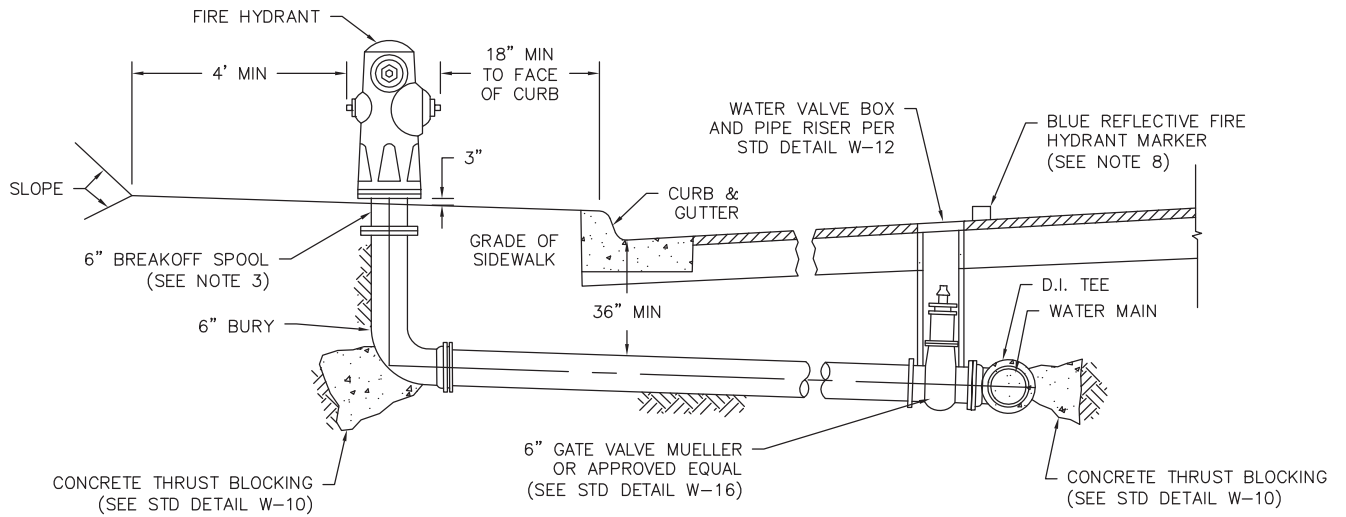

SECTION VIEW
SCALE: NTS

NOTES

1. ALL HOSE OUTLET CAPS SHALL BE ATTACHED TO HYDRANT BY CHAIN.
2. HYDRANT SHALL BE IN ACCORDANCE WITH AWWA STANDARDS, TESTED AND APPROVED BY UNDERWRITERS LABORATORIES, OR EQUIVALENT.
3. FIRE HYDRANT AND EXPOSED BREAKOFF SPOOL SHALL BE PAINTED WITH DUPONT 30-10 WHITE ENAMEL PRIMER, FOLLOWED WITH A FINISH COAT OF NO. 612-00 WHITE FULLER O'BRIEN HEAVY DUTY, HIGH GLOSS PAINT.
4. HYDRANTS LOCATED IN PAVED OR TRAVELED WAY SHALL BE PROTECTED BY FOUR BOLLARDS AS SHOWN IN BOLLARD PLACEMENT DETAIL.
5. EACH BOLLARD SHALL BE PROFESSIONALLY CLEANED AND PAINTED WITH ONE COAT OF PRIMER AND ONE FINISH COAT OF YELLOW EXTERIOR GRADE LATEX PAINT.
6. BOLLARDS SHALL BE SET IN CONCRETE, SET VERTICALLY AND PLUMBED. SEE STD DETAIL L-8 FOR BOLLARD DETAILS.
7. HYDRANTS SHALL BE CENTERED ON 2' SQUARE, 4" THICK CONCRETE PAD WHEN PLACED IN LANDSCAPE OR PLANTING STRIP.
8. BLUE REFLECTIVE FIRE HYDRANT MARKER SHALL BE LOCATED PER CA MUTCD (LATEST EDITION) FIGURE 3B-102 (CA).

HOSE OUTLETS:
(2) 2-1/2" NOZZLES
(1) 4-1/2" NOZZLE

MAKE	MODEL
CLOW	960
OR APPROVED EQUAL	

APPROVED

3/8/23

DATE

DRAFT

	NO.	DATE	REVISION	DRAWN BY: BJR	<p>STANDARD DETAIL</p> <p>HYDRANT INSTALLATION - COMMERCIAL AND INDUSTRIAL</p>	<p>SHEET 2 OF 2</p> <p>W-4</p>
	1	2019-01-11	NOTES 7&8, HYDRANT MODELS, BOLLARDS	CHECKED BY: MK		
				DATE: 2019-01-11		
				SCALE: NTS		

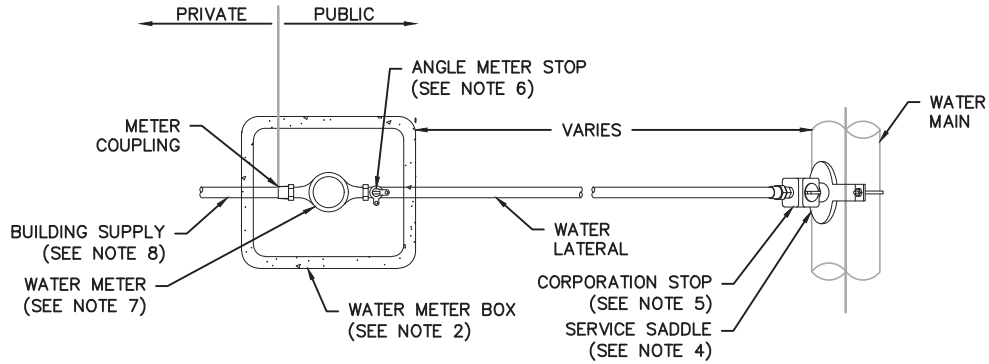

PLAN VIEW
SCALE: NTS

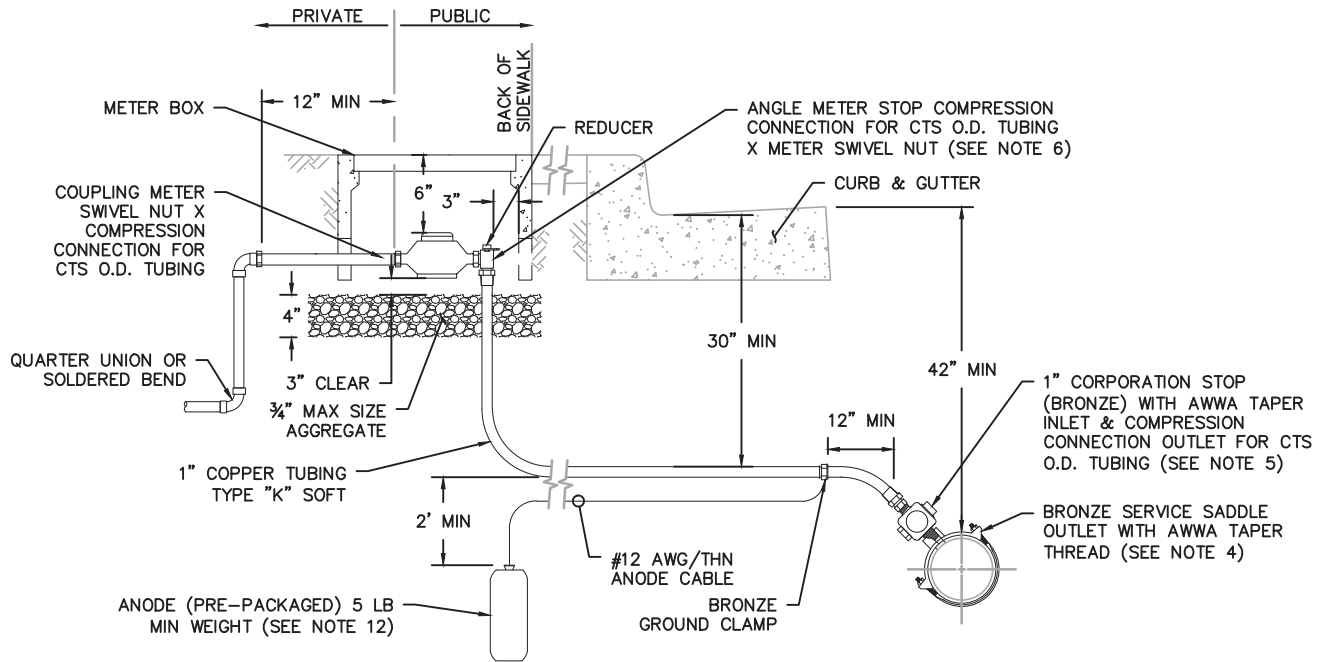

SECTION VIEW
SCALE: NTS

NOTES

1. AFTER PAYMENT OF FEES, WATER METER SHALL BE FURNISHED AND INSTALLED BY THE CITY FOR NEW SERVICES.
2. METER BOX SHALL BE CHRISTY B9X WITH FL9X LID FOR 3/4-INCH AND SMALLER METERS, CHRISTY B16 WITH FL16D LID FOR 1-INCH METERS (OR APPROVED EQUALS).
3. WHERE METER BOX IS TO BE LOCATED IN AN AREA SUBJECT TO VEHICULAR TRAFFIC LOADING, THE PERMITTEE SHALL FURNISH A REGULAR BOX. TRAFFIC BOX COVER SHALL BE FL12BOX WITH FL12D LID FOR 5/8" X 3/4" THROUGH 1-INCH METERS (OR APPROVED EQUAL).
4. FOR PIPES UP TO 12" IN DIAMETER, THE SERVICE SADDLE SHALL BE MUELLER H-13000 SERIES (OR APPROVED EQUAL). FOR PIPES LARGER THAN 12" IN DIAMETER, THE SERVICE SADDLE SHALL BE MUELLER BR2B OR BR2S SERIES (OR APPROVED EQUAL). SADDLES FOR PVC PIPE SHALL BE DOUBLE OR WIDE STRAP DESIGN.
5. CORPORATION STOP SHALL BE MUELLER B-25008N (OR APPROVED EQUAL).
6. ANGLE METER STOP SHALL BE MUELLER B-24258N (OR APPROVED EQUAL).
7. WATER METER SHALL BE LOCATED IN THE CENTER OF WATER METER BOX.
8. WATER LATERAL TO BE SIZED PER THE REQUIREMENTS OF THE LATEST VERSION OF CALIFORNIA PLUMBING CODE.
9. ALL WATER SERVICE FITTINGS SHALL BE LEAD-FREE.
10. WHERE THE MATERIAL FOR SERVICE FITTINGS IS SPECIFIED TO BE BRONZE, BRASS FITTINGS MAY BE USED.
11. 1" X 3/4" BRASS REDUCER SHALL BE USED FOR 5/8" X 3/4" METER.
12. 5 LB MINIMUM ANODE REQUIRED ON ALL COPPER SERVICE LINES 2" AND SMALLER UNLESS GEOTECHNICAL REPORT STIPULATES IT IS NOT NECESSARY. ADDITIONAL WEIGHT MAY BE REQUIRED BY GEOTECHNICAL REPORT. INSULATING COUPLING REQUIRED BETWEEN COPPER WATER LATERAL AND WATER MAIN IF MAIN IS METALLIC.

APPROVED

3/8/23

DATE



CITY OF
PITTSBURG

NO.	DATE	REVISION	DRAWN BY:	BJR
1	2019-01-11	ADDED ANODE	CHECKED BY:	MK
			DATE:	2019-01-11
			SCALE:	NTS

STANDARD DETAIL

1" COPPER WATER SERVICE FOR
5/8"X3/4" & 1" WATER METERS

SHEET 1 OF 5

W-5

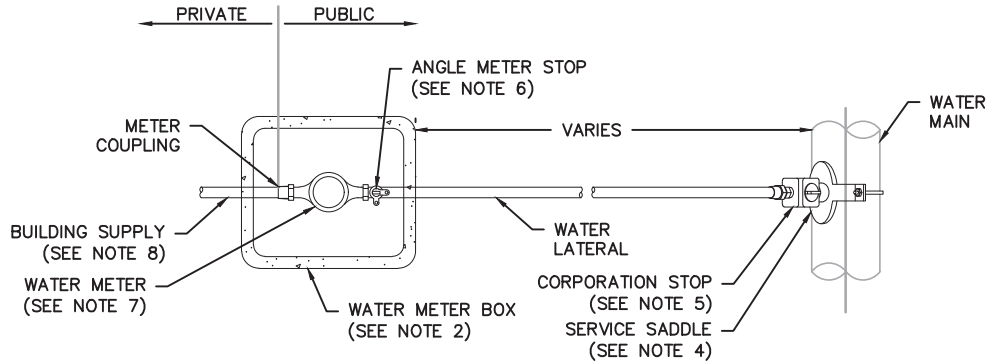

PLAN VIEW
SCALE: NTS

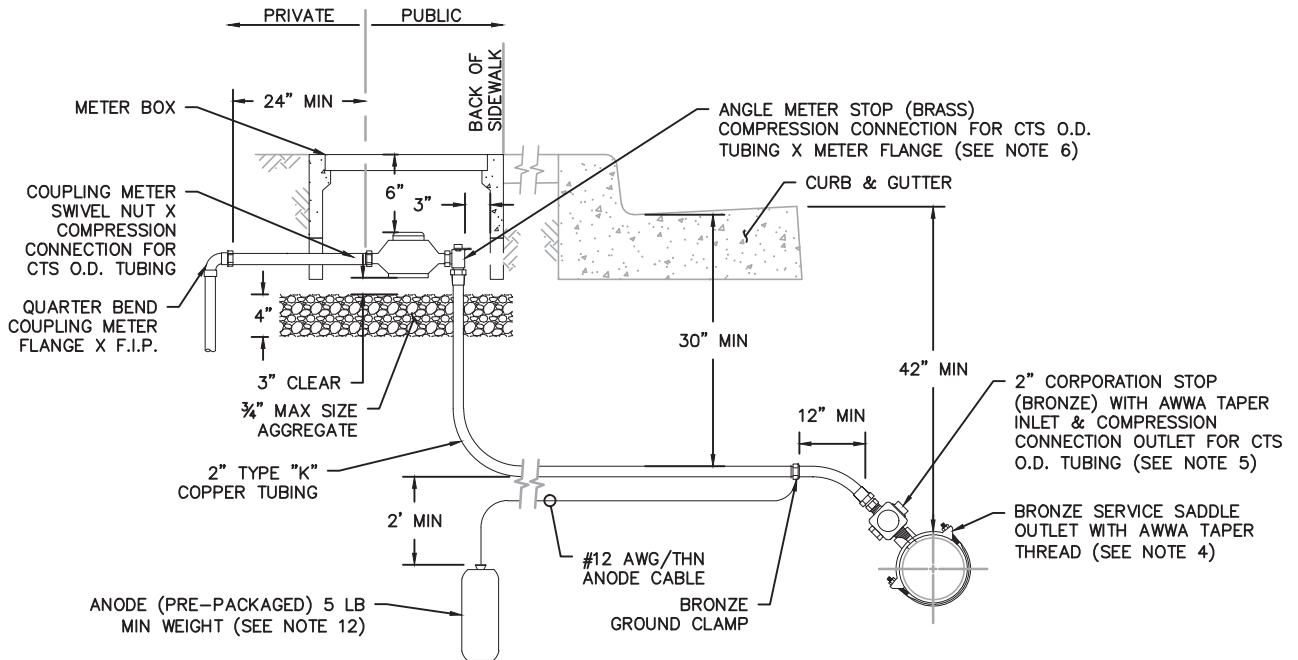

SECTION VIEW
SCALE: NTS

NOTES

1. AFTER PAYMENT OF FEES, WATER METER SHALL BE FURNISHED AND INSTALLED BY THE CITY FOR NEW SERVICES.
2. METER BOX SHALL BE CHRISTY B36 (17 1/4" x 30") WITH FL36E LID (OR APPROVED EQUAL).
3. WHERE METER BOX IS TO BE LOCATED IN AN AREA SUBJECT TO VEHICULAR TRAFFIC LOADING, THE PERMITTEE SHALL FURNISH A TRAFFIC BOX FOR H/20 LOADING. TRAFFIC BOX SHALL BE CHRISTY B10" X17" WITH B36-616 LID (OR APPROVED EQUAL).
4. FOR PIPES UP TO 12" IN DIAMETER, THE SERVICE SADDLE SHALL BE MUELLER H-13000 SERIES CC TAPERED THREAD (OR APPROVED EQUAL). FOR PIPES LARGER THAN 12" IN DIAMETER, THE SERVICE SADDLE SHALL BE MUELLER BR2B OR BR2S SERIES (OR APPROVED EQUAL). SADDLES FOR PVC PIPE SHALL BE DOUBLE OR WIDE STRAP DESIGN
5. CORPORATION STOP SHALL BE 2" MUELLER B-25008N (OR APPROVED EQUAL).
6. ANGLE METER STOP SHALL BE 2" MUELLER B-24276N (OR APPROVED EQUAL).
7. WATER METER SHALL BE LOCATED IN THE CENTER OF WATER METER BOX.
8. MINIMUM COVER OVER BUILDING SUPPLY (YARD PIPING) SHALL NOT BE LESS THAN THAT SPECIFIED IN THE UNIFORM PLUMBING CODE.
9. WATER SERVICES TO BE SIZED PER THE REQUIREMENTS OF THE LATEST VERSION OF CALIFORNIA PLUMBING CODE.
10. ALL WATER SERVICE FITTINGS SHALL BE LEAD-FREE.
11. THE METER BOX FOR A 1-1/2-IN TURBINE METER SHALL BE A CHRISTY B-30 BOX WITH B-30E LID (OR B-30-61G LID FOR TRAFFIC AREAS), OR APPROVED EQUALS. THE METER BOX FOR A 2-IN TURBINE METER SHALL BE A CHRISTY B-36 BOX WITH B-36E LID (OR B-36-61G LID FOR TRAFFIC AREAS), OR APPROVED EQUALS.
12. 5 LB MINIMUM ANODE REQUIRED ON ALL COPPER SERVICE LINES 2" AND LESS UNLESS GEOTECHNICAL REPORT STIPULATES IT IS NOT NECESSARY. ADDITIONAL WEIGHT MAY BE REQUIRED BY GEOTECHNICAL REPORT. INSULATING COUPLING REQUIRED BETWEEN COPPER WATER LATERAL AND WATER MAIN IF MAIN IS METALLIC.

APPROVED

3/8/23

DATE



CITY OF
PITTSBURG

NO.	DATE	REVISION	DRAWN BY:	BJR
1	2019-01-11	ADDED ANODE	CHECKED BY:	MK
			DATE:	2019-01-11
			SCALE:	NTS

STANDARD DETAIL

2" COPPER WATER SERVICE FOR
1-1/2" & 2" WATER METERS

SHEET 2 OF 5

W-5

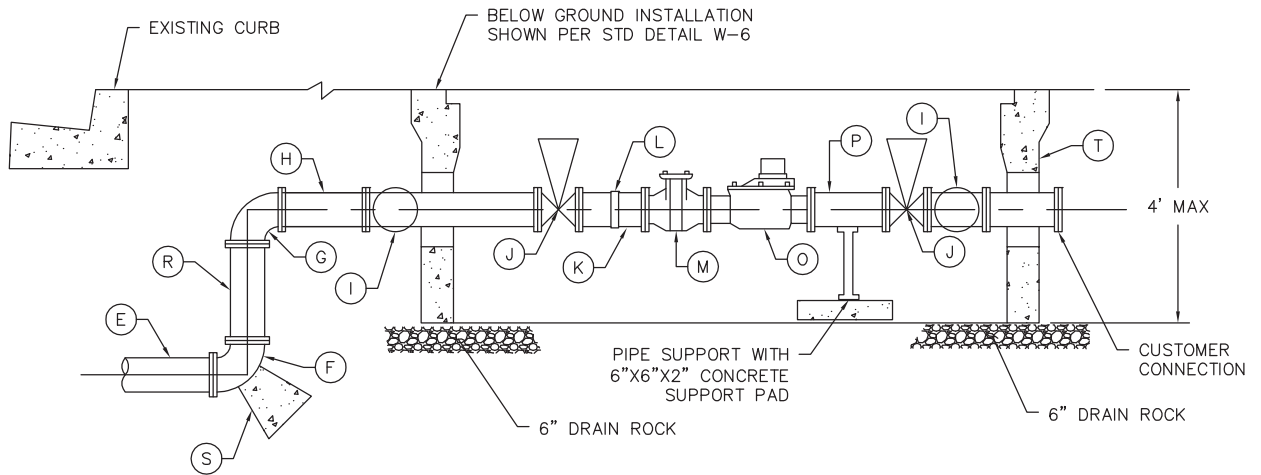
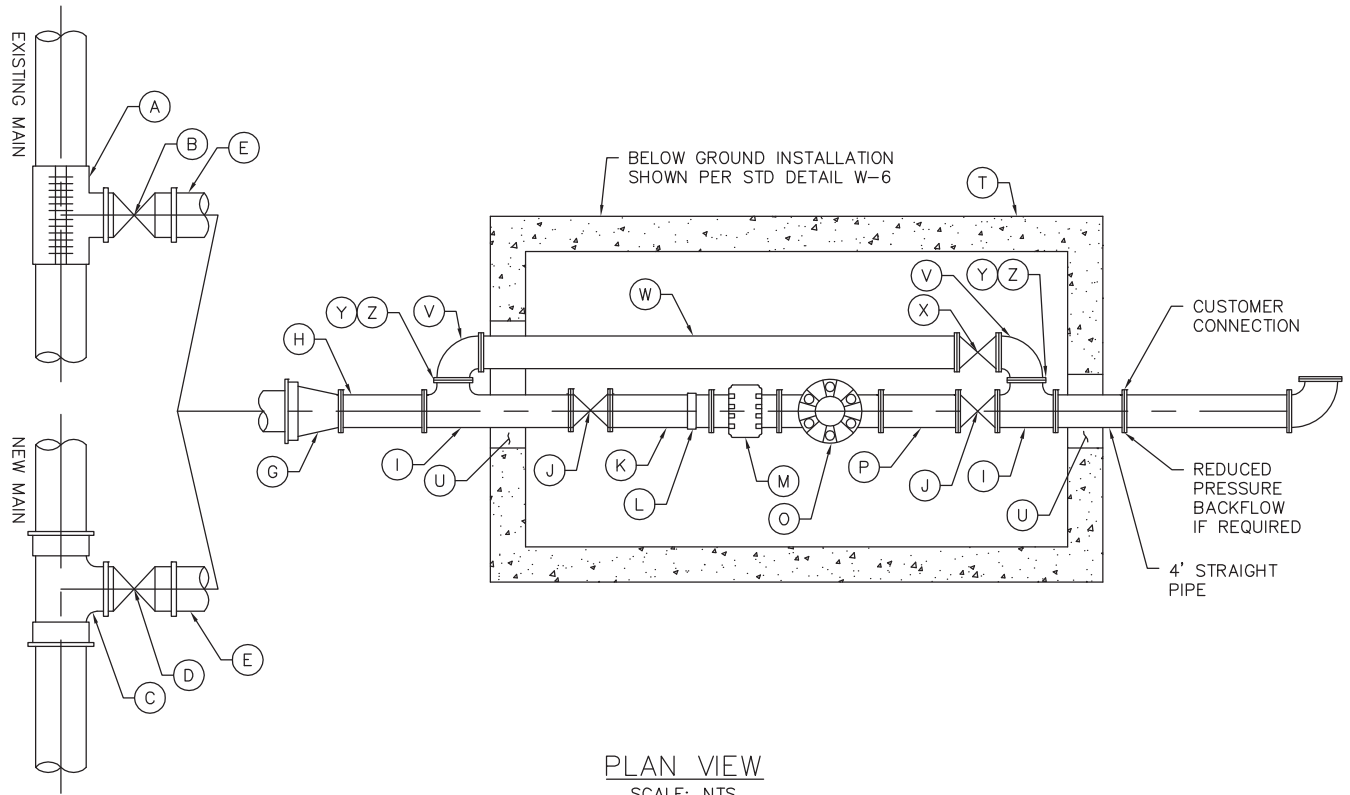

NOTES

1. SEE SHEET 5 FOR NOTES AND MATERIALS.

APPROVED

3/8/23

DATE

DRAFT



CITY OF
PITTSBURGH

NO.	DATE	REVISION	DRAWN BY:
1	2019-01-11	REVISED MATERIALS	BJR
			CHECKED BY: MK
			DATE: 2019-01-11
			SCALE: NTS

STANDARD DETAIL

WATER SERVICE FOR 3" & 4"
WATER METERS

SHEET 3 OF 5

W-5

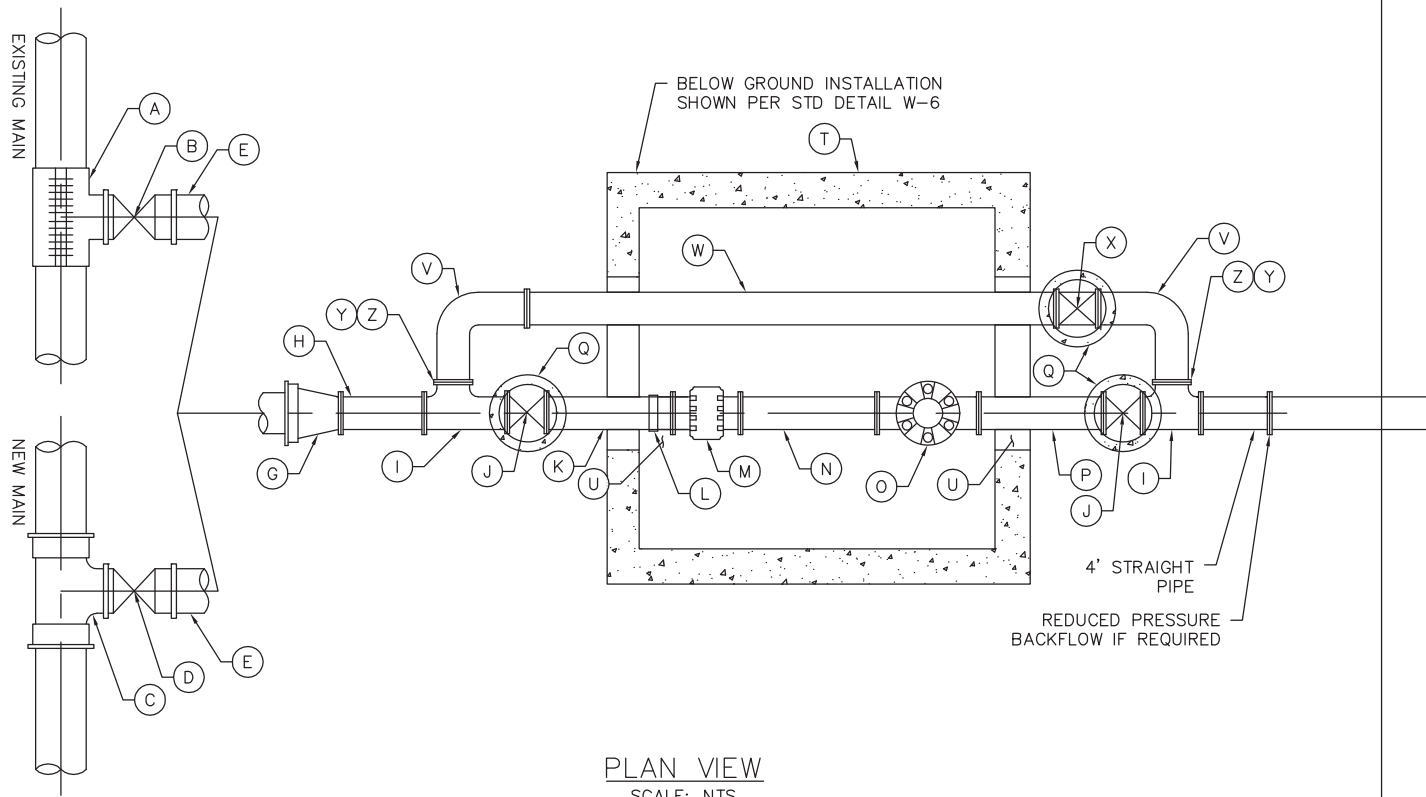

PLAN VIEW
SCALE: NTS

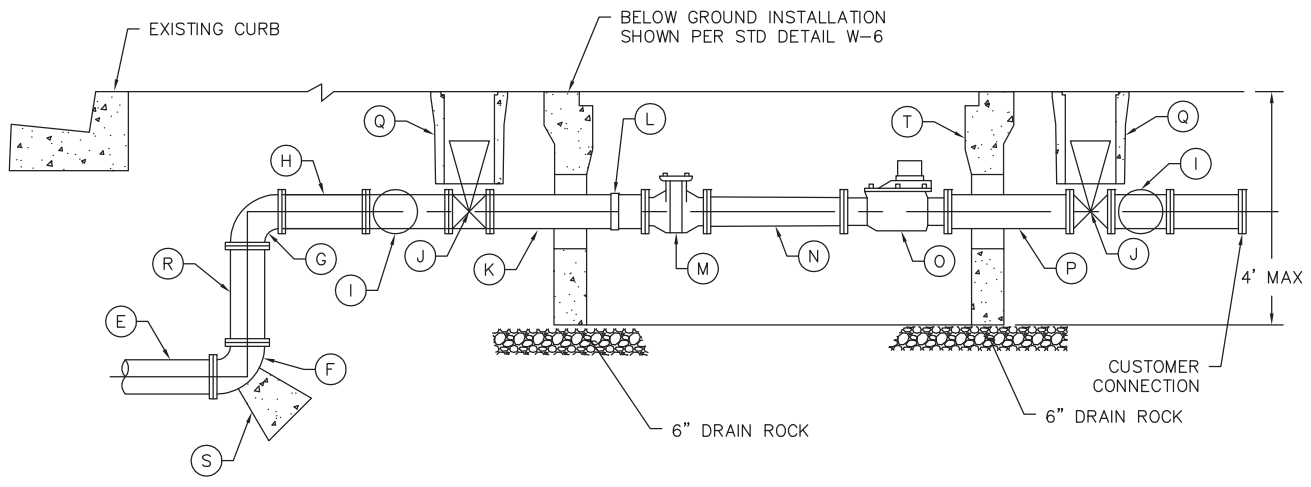

SECTION VIEW
SCALE: NTS

NOTES

1. SEE SHEET 5 FOR NOTES AND MATERIALS.

APPROVED  3/8/23
DATE

 CITY OF PITTSBURGH	NO.	DATE	REVISION	DRAWN BY:	AW	<u>STANDARD DETAIL</u> WATER SERVICE FOR 6" WATER METERS	SHEET 4 OF 5
	1	2019-01-11	REVISED MATERIALS	CHECKED BY:	MK		W-5
				DATE:	2019-01-11		
				SCALE:	NTS		

DRAFT

LIST OF MATERIALS				
ITEM	DESCRIPTION	3" METER	4" METER	6" METER
A	bolted tapping sleeve	Main size x 4"	Main size x 4"	Main size x 6"
B	Flg x M.J. tapping valve	4"	4"	6"
C	M.J. x M.J. x Flg tee	Main size x 4"	Main size x 4"	Main size x 6"
D	Flg x M.J. gate valve and box	4"	4"	6"
E	Class 52 D.I. pipe	4"	4"	6"
F	M.J. x Flg elbow	4"	4"	6"
G	M.J. x Flg reducer elbow	4" x 3"	---	---
	M.J. x Flg elbow	---	4"	6"
H	Flg D.I. spool (12" length min)	3"	4"	6"
I	Flg x Flg x Flg tee	3"	4"	6"
J	Flg gate valve	3"	4"	6"
K	Flg x Flg nipple (cut in half)	3" x 15"	4" x 20"	6" x 30"
L	flex coupling (Mueller or approved equal)	3"	4"	6"
M	water strainer (provided by City)	Badger Meter Recordall Turbo Series Meter, Model 450 with integral strainer**	Badger Meter Recordall Turbo Series Meter, Model 1000 with integral strainer**	Badger Meter 6" plate strainer**
N	Flg D.I. spool			6" x 30"
O	water meter (provided by City)			Badger Meter Recordall Turbo Series Meter, Model 2000**
P	Flg D.I. spool	3" x 12"	4" x 16"	6" x 24"
Q	valve box	---	---	Christy G05T box**
	valve lid	---	---	Christy G05CT lid**
R	Flg D.I. spool	4"	4"	6"
S	thrust block	See City Standard Detail W-10 for Concrete Thrust Blocking		
T	meter box	Christy R37 P36 Pit**	Christy R37 P36 Pit**	Christy R37 P36 Pit**
	meter lid (torsion-assisted, ADA-rated, steel-hinged, double leaf)	Christy R37-52HT**	Christy R37-52HT**	Christy R37-52HT**
U	8" opening and grout	---	---	---
	By-Pass	2"	2"	4"
V	MIPT x P.J. elbow	2"	2"	4"
W	Type K copper	2"	2"	4"
X	ball valve, MIPT x FIPT with locking ears	2"	2"	4"
Y	nylon bushing	2-1/2" x 2"	2-1/2" x 2"	4-1/2" x 4"
Z	FIPT reducing flange	3" x 2-1/2"	4" x 2-1/2"	6" x 4-1/2"
** or approved equal				

APPROVED



3/8/23

DRAFT

DATE



CITY OF PITTSBURGH

NO.	DATE	REVISION	DRAWN BY:
1	2019-01-11	REVISED MATERIALS	
			CHECKED BY: MK
			DATE: 2019-01-11
			SCALE: NONE

STANDARD DETAIL
WATER SERVICE FOR 3" THRU 6"
WATER METERS - NOTES AND
MATERIALS

SHEET 5 OF 5

W-5

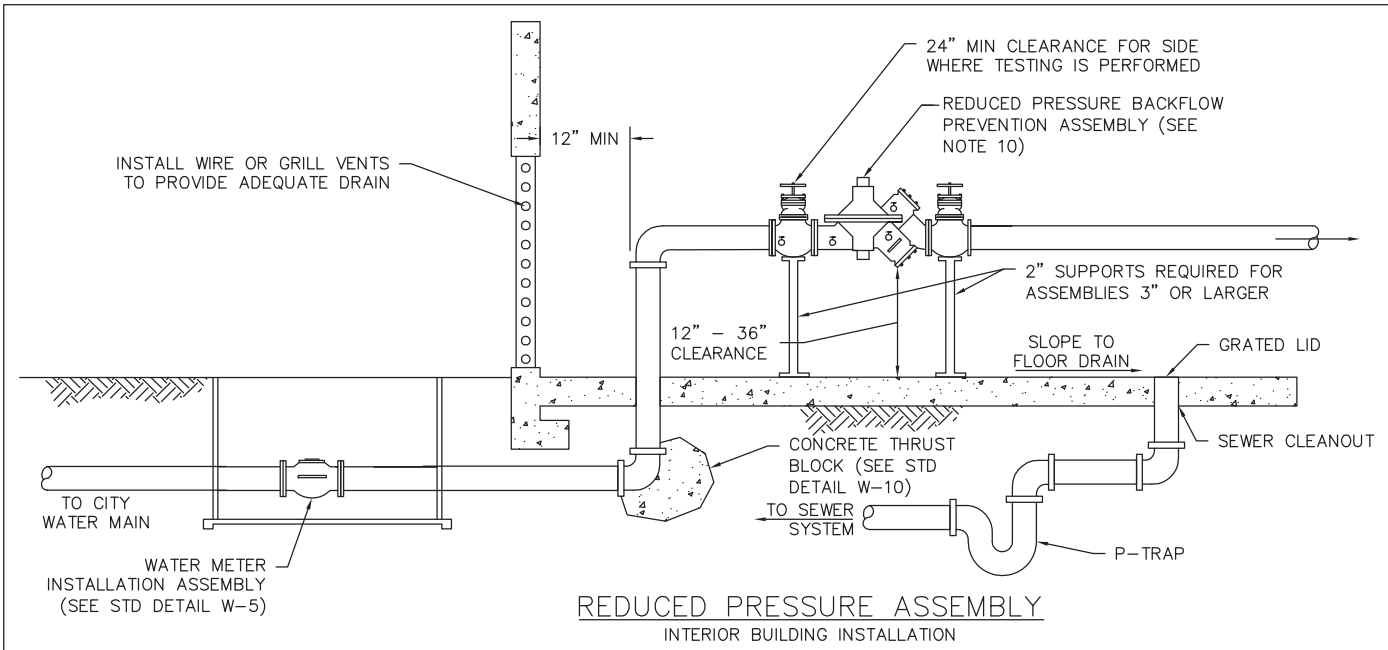

REDUCED PRESSURE ASSEMBLY
INTERIOR BUILDING INSTALLATION

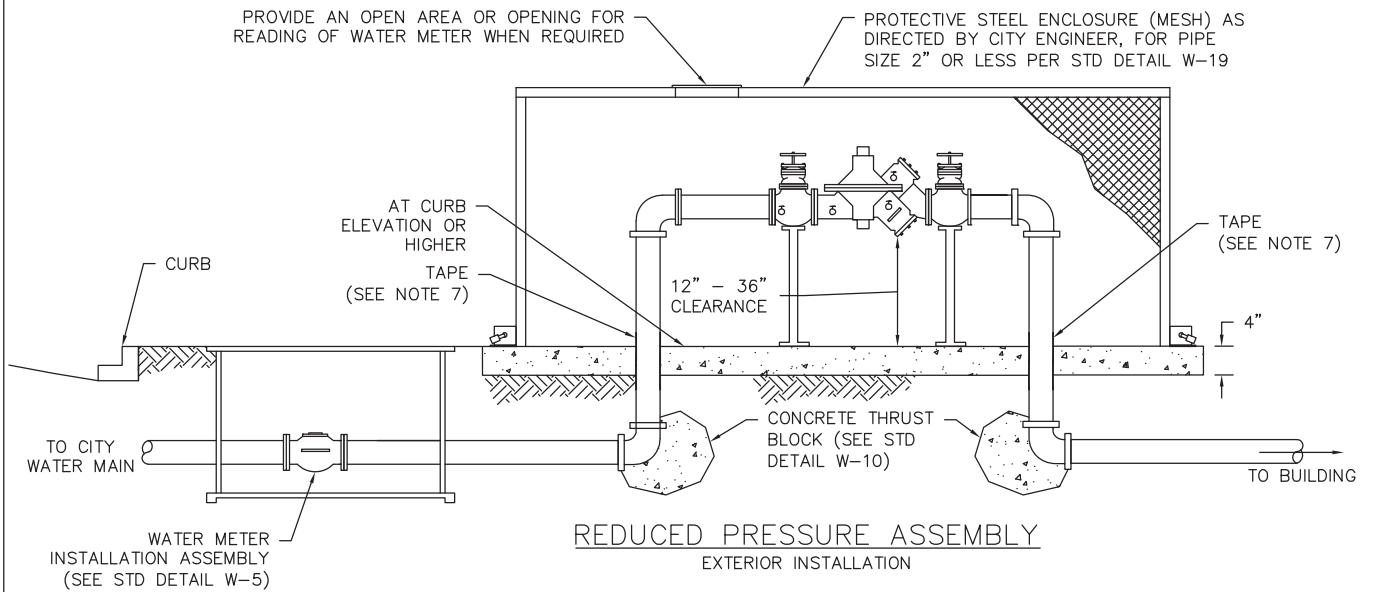

REDUCED PRESSURE ASSEMBLY
EXTERIOR INSTALLATION

NOTES

1. POINT OF SERVICE:
 - A. POINT OF SERVICE IS AT THE BACK OF CURB FOR ALL CITY STREETS WITH PLANTER STRIPS.
 - B. POINT OF SERVICE IS AT THE BACK OF SIDEWALK FOR STREETS WITH COMBINED CURB AND SIDEWALK.
 - C. POINT OF SERVICE IS AT THE RIGHT-OF-WAY LINE ON ALL UNIMPROVED STREETS AND ALLEYS.
2. LISTS OF APPROVED (BY STATE & CITY) BACKFLOW PREVENTION ASSEMBLIES AND CERTIFIED BACKFLOW PREVENTION ASSEMBLY TESTERS ARE AVAILABLE AT CITY OF PITTSBURG, PUBLIC WORKS DEPT. AT 357 E. 12TH ST. AND/OR AT THE ENGINEERING DEPARTMENT AT 65 CIVIC AVE.
3. THE BACKFLOW PREVENTION ASSEMBLIES SHALL BE INSTALLED ABOVE GROUND, IN A HORIZONTAL AND LEVEL POSITION UNLESS OTHERWISE APPROVED BY THE ENGINEERING DEPARTMENT OR PUBLIC WORKS DEPARTMENT.
4. NO ADDITIONAL CONNECTIONS (OUTLET, TAP OR TEE) ARE PERMITTED BETWEEN THE WATER MAIN AND BACKFLOW PREVENTION ASSEMBLY.
5. BACKFLOW ASSEMBLIES SHALL NOT BE INSTALLED IN BASEMENTS OR VAULTS.
6. DETAILS OF METER SCHEMATIC ONLY. REFER TO W-5 FOR SPECIFIC LAYOUT REQUIRED.
7. PROVIDE 20 MIL TAPE BETWEEN COPPER SUPPLY LINE AND CONCRETE PAD 4" ABOVE AND BELOW CONCRETE.
8. ALL VISIBLE PORTIONS OF THE ASSEMBLY (LARGER THAN 2") SHALL BE PAINTED TO MATCH THE BUILDING AS APPROVED BY THE CITY ENGINEER.
9. PROVIDE A 2" MINIMUM BYPASS ON ALL BFDs (SEE STD DETAIL W-5, SHEET 3). PROVIDE A REDUCED PRESSURE BACKFLOW PREVENTION DETECTOR ON THE BYPASS 3" AND UP.
10. REDUCED PRESSURE BACKFLOW PREVENTION ASSEMBLY PER UNIVERSITY OF SOUTHERN CALIFORNIA'S FOUNDATION FOR CROSS CONNECTION CONTROL AND HYDRAULIC RESEARCH'S LIST OF APPROVED BACKFLOW PREVENTION ASSEMBLIES.

APPROVED  **3/8/23**
DATE

 CITY OF PITTSBURG	NO.	DATE	REVISION	DRAWN BY: BJR	STANDARD DETAIL REDUCED PRESSURE BACKFLOW PREVENTION ASSEMBLIES	SHEET 1 OF 2 W-6
	1	2019-01-11	NOTES 6-10, ADDED FLOOR DRAIN	CHECKED BY: MK		
				DATE: 2019-01-11		
				SCALE: NTS		

DRAFT

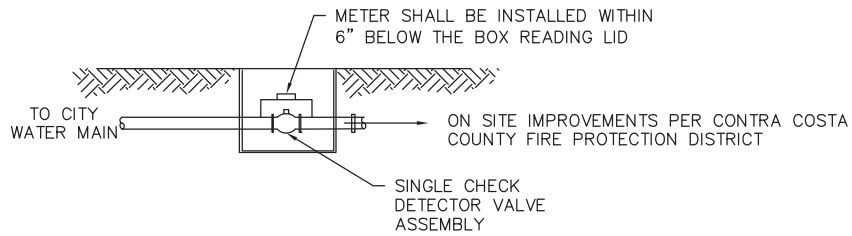

CLASS I & II FIRE PROTECTION SYSTEM
(NO HAZARD CONDITION)

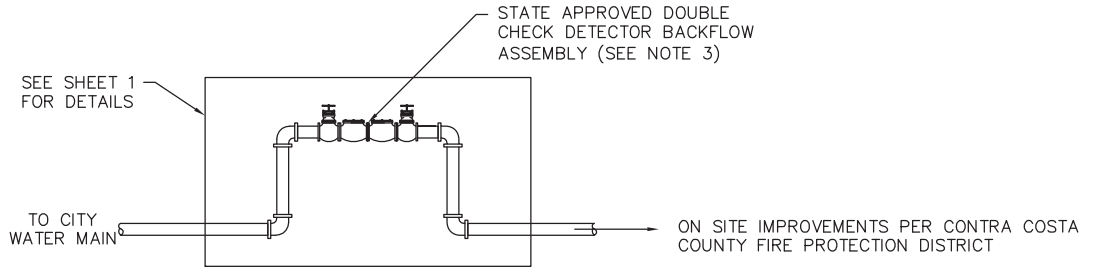

CLASS III FIRE PROTECTION SYSTEM
(LOW HAZARD CONDITION)

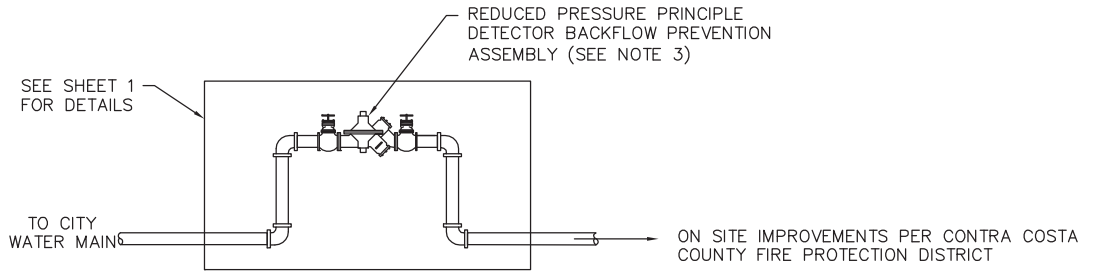

CLASS IV & V FIRE PROTECTION SYSTEM
(LOW / HIGH HAZARD CONDITION)

NOTES

1. FIRE PROTECTION SYSTEMS

CLASS I & II: DIRECT CONNECTIONS FROM PUBLIC WATER MAINS ONLY, NO PHYSICAL CONNECTION FROM OTHER WATER SUPPLIES (TANKS, RESERVOIRS) AND ALL SPRINKLER DRAINS DISCHARGE TO THE ATMOSPHERE OR OTHER SAFE OUTLETS. CLASS II SAME AS CLASS I EXCEPT THAT BOOSTER PUMPS MAY BE INSTALLED.

CLASS III (LOW HAZARD): DIRECT CONNECTION FROM PUBLIC WATER SUPPLY MAIN PLUS ONE OR MORE OF THE FOLLOWING: ELEVATED STORAGE TANKS, FIRE PUMPS TAKING SUCTION FROM ABOVE GROUND, COVERED RESERVOIRS OR TANKS

CLASS IV (LOW HAZARD): SIMILAR TO CLASS I & II BUT WHICH USES OR HAS AVAILABLE FOR USE AN UNAPPROVED AUXILIARY WATER SUPPLY.

CLASS V (HIGH HAZARD): SUPPLIED FROM PUBLIC MAINS AND INTERCONNECTED WITH AN UNAPPROVED AUXILIARY WATER EXPOSED TO CONTAMINATION (HARBORS, RIVERS, PONDS, WELLS OR INDUSTRIAL FLUIDS). THE APPROPRIATE BACKFLOW PREVENTION ASSEMBLY SHALL BE DETERMINED AFTER THE FIRE MARSHAL AND THE ENGINEERING DEPARTMENT HAVE MADE A COMPLETE SURVEY OF THE FIRE PROTECTION REQUIREMENTS OF THE PREMISES.

2. ALL FIRE PROTECTION SYSTEMS HAVE DETECTOR METERS ONLY AND DO NOT REQUIRE SERVICE METERS.

3. REDUCED PRESSURE BACKFLOW PREVENTION ASSEMBLY PER UNIVERSITY OF SOUTHERN CALIFORNIA'S FOUNDATION FOR CROSS CONNECTION CONTROL AND HYDRAULIC RESEARCH'S LIST OF APPROVED BACKFLOW PREVENTION ASSEMBLIES.

APPROVED _____

3/8/23

DATE

DRAFT



CITY OF
PITTSBURG

NO.	DATE	REVISION	DRAWN BY:
1	2019-01-11	NOTES 2&3	BJR
			CHECKED BY: MK
			DATE: 2019-01-11
			SCALE: NTS

STANDARD DETAIL

BACKFLOW PREVENTION ASSEMBLIES
FOR FIRE PREVENTION SYSTEMS

SHEET 2 OF 2

W-6

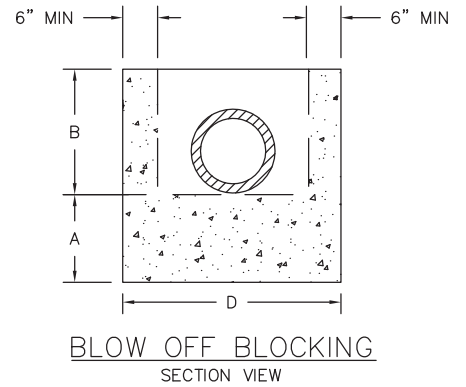
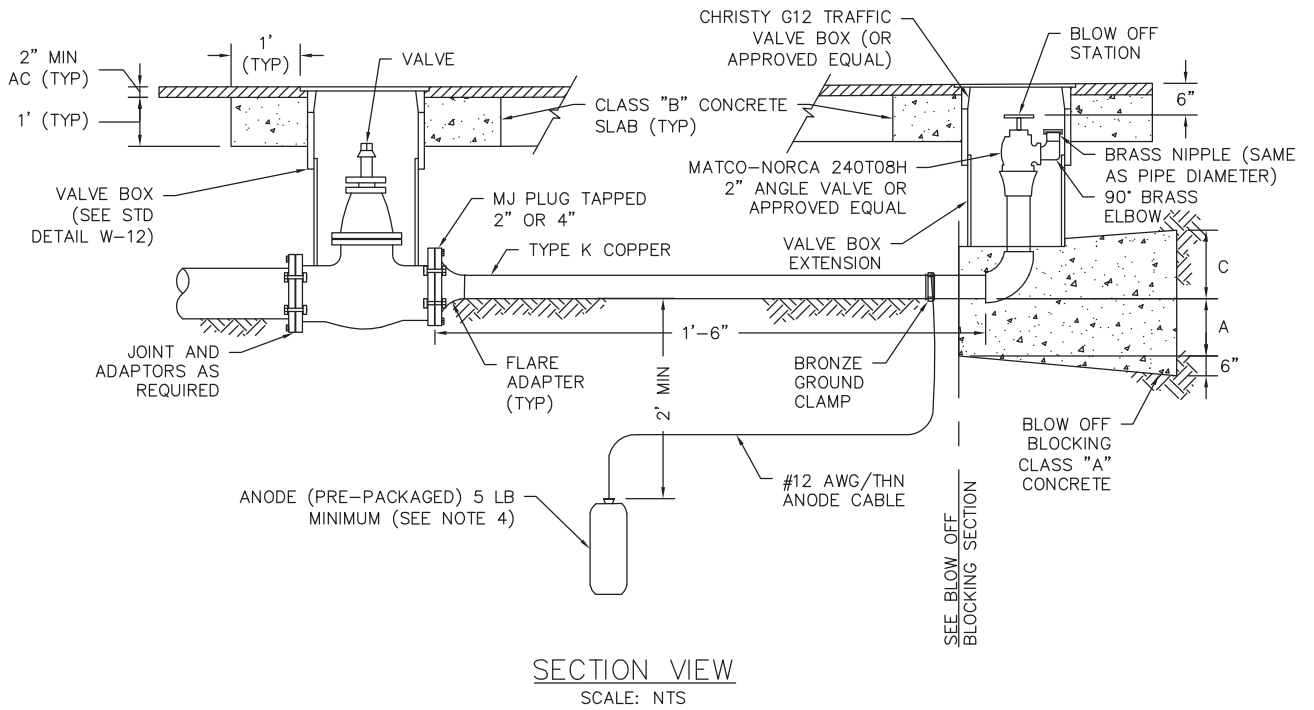

NOTES

1. THE BLOW OFFS FOR FUTURE EXTENSION STUB SHALL BE PRESSURE TESTED AND CHLORINATED WITH THE REST OF THE MAIN BLOW OFF STATION. BACTERIOLOGICAL SAMPLING SHALL BE PERFORMED BY THE CITY.
2. BLOW OFF SHALL BE 2" PIPE (6" & 8" MAIN) OR 4" PIPE (10" & 12" MAIN).
3. REFER TO STD DETAIL W-12 FOR VALVE BOX INSTALLATION ASSEMBLY.
4. 5 LB MINIMUM ANODE REQUIRED ON ALL COPPER SERVICE LINES 2" AND LESS UNLESS GEOTECHNICAL REPORT STIPULATES IT IS NOT NECESSARY. ADDITIONAL WEIGHT MAY BE REQUIRED BY GEOTECHNICAL REPORT. INSULATING COUPLING REQUIRED BETWEEN COPPER WATER LATERAL AND WATER MAIN IF MAIN IS METALLIC.

TABLE 1: MINIMUM DIMENSIONS FOR THRUST BLOCKS

MAIN SIZE	A	B	C	D
6"	1'-0"	1'-0"	2'-0"	2'-0"
8"	1'-4"	1'-2"	2'-0"	2'-0"
10"	1'-9"	1'-6"	3'-0"	3'-0"
12"	2'-0"	1'-8"	3'-0"	3'-0"

APPROVED 3/8/23

DATE

DRAFT

	NO.	DATE	REVISION	DRAWN BY:	BJR
	1	2019-01-11	ADDED ANODE	CHECKED BY:	MK
				DATE:	2019-01-11
				SCALE:	NTS

STANDARD DETAIL
BLOW OFF

SHEET 1 OF 1
W-8

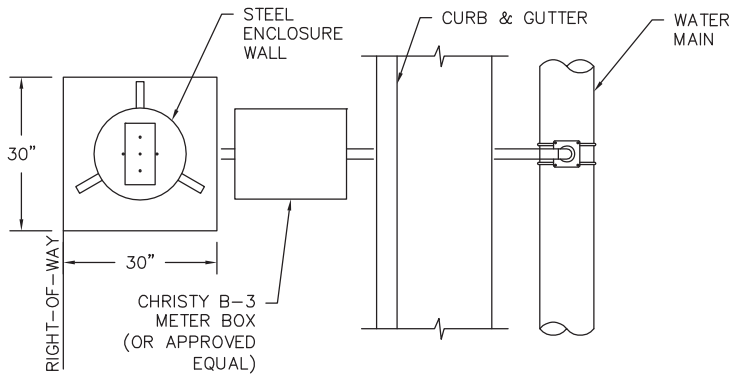

PLAN VIEW
SCALE: NTS

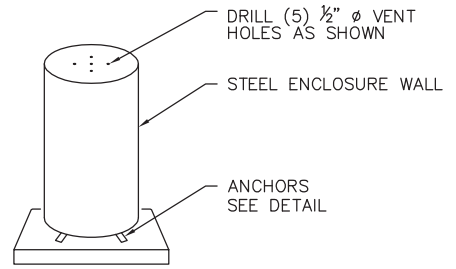

STEEL ENCLOSURE

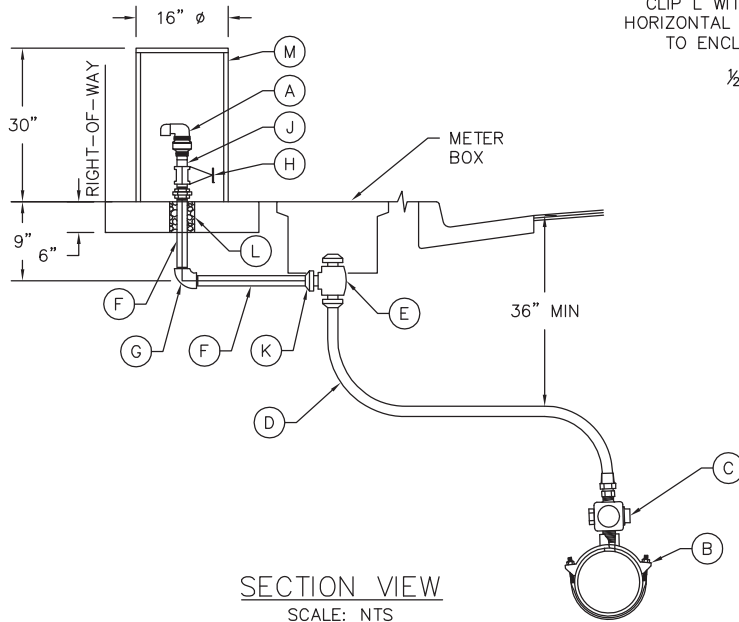

SECTION VIEW
SCALE: NTS

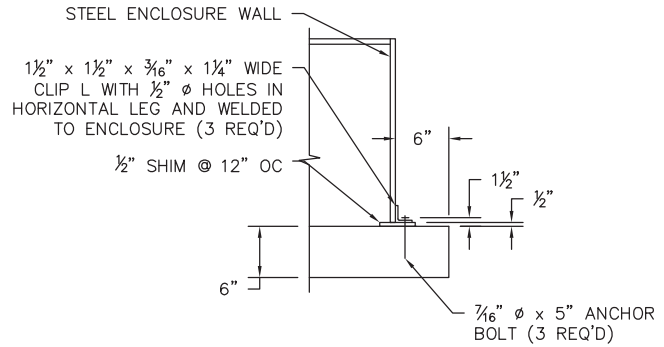

ANCHOR DETAIL
SECTION VIEW

NOTES

- WHERE SIDEWALKS ARE ADJACENT TO CURBS, PIPE COVERS SHALL BE CENTERED IN 2'-6" SQUARE CONCRETE PAD (4" THICK) AT BACK OF RIGHT-OF-WAY LINE. IF SIDEWALK IS NOT ADJACENT TO CURB, LOCATE 2'-6" CONCRETE PAD WITHIN PARKWAY BETWEEN SIDEWALK AND CURB FACE. FOR ASSEMBLY OUTSIDE OF AN EXIST STREET, LOCATE CENTER OF AIR VAC 5 FEET FROM CENTERLINE OF WATER MAIN.
- ALL PIPE, FITTINGS AND VALVES SHALL BE RATED AT PRESSURE CLASS OF WATER MAIN.
- INSTALL FOUR (4) MARKER POST PER STD DETAIL W-2 AT EACH AIR VAC ASSEMBLY OUTSIDE OF AN EXIST STREET.

LIST OF MATERIALS	
ITEM	DESCRIPTION
A	2" COMBINATION AIR AND VACUUM CAV RELEASE VALVE - A.R.I. D-040**
B	2" BRONZE STRAP SERVICE SADDLE - MUELLER H-13000 SERIES**
C	2" BRONZE CORPORATION STOP - MUELLER B-25008N** W/ DIELECTRIC INSULATING FITTING
D	2" TYPE "K" COPPER TUBING
E	2" BRONZE ANGLE METER VALVE - MUELLER B-24276N**
F	2" BRASS NIPPLE
G	2" 90° BRASS ELBOW
H	2" GATE VALVE WITH BRONZE HANDWHEEL - JONES J-372, CLOW R/W, MUELLER A-2360**
J	2" BRASS SHORT NIPPLE
K	BRONZE WATER METER FLANGE x FIP.
L	8" PVC SLEEVE - PACK WITH GRAVEL.
M	ENCLOSURE - 16" diameter HOT DIP 10 GAUGE STEEL GALVANIZED, 30" TALL - PIPELINE VC-216**

** or approved equal

APPROVED

3/8/23

DATE

DRAFT



CITY OF PITTSBURGH

NO.	DATE	REVISION	DRAWN BY:
1	2019-01-11	REVISED MATERIALS	BJR
			CHECKED BY: MK
			DATE: 2019-01-11
			SCALE: NTS

STANDARD DETAIL

COMBINATION AIR VALVE ASSEMBLY

SHEET 1 OF 1

W-9

NOTES

1. ALL CONCRETE SHALL HAVE A COMPRESSIVE STRENGTH OF 4,000 PSI @ MIN 28-DAYS.
2. THRUST BLOCKS SHALL BE PLACED SYMMETRICALLY ABOUT THE FITTING.
3. ALL CONCRETE BLOCKS TO BE KEPT CLEAR OF BALLS, LUGS AND BOLTS.
4. UNSUPPORTED SURFACES TO BE FORMED.
5. BASED ON 200 PSI TOTAL TEST, 2000 PSF SOIL BEARING, AND SAFETY FACTOR 1.0.
6. INCREASE ALL BEARING AREAS FOR SOFT MATERIALS, AS APPROVED BY THE CITY ENGINEER.
7. ALL FITTINGS AND VALVES SHALL BE COATED WITH MASTIC PRIOR TO POURING OF THRUST BLOCKS.
8. C1=11¼" DEFLECTION. C2=22½" DEFLECTION. C3=45" DEFLECTION. A=TEE / PLUGGED TEE / PLUGGED END / PLUGGED CROSS / PLUGGED WYE.
9. SEE SHEET 3 FOR UPWARD FORCE VERTICAL BENDS.

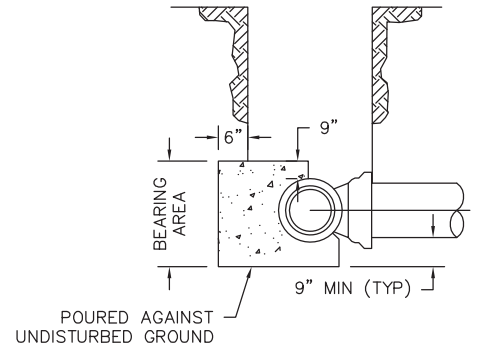

TYPICAL SECTION

TABLE 1: CONCRETE THRUST BLOCKS						
MINIMUM REQUIRED BEARING AREAS (SQARE FEET)						
PIPE SIZE		DEFLECTION				
		A (TEE/PLUGGED)	B (90°)	C1 (11¼")	C2 (22½")	C3 (45°)
		4"	1.81	2.56	0.36	0.71
6"	3.74	5.29	0.73	1.46	2.86	
8"	6.43	9.10	1.26	2.51	4.92	
10"	9.68	13.69	1.90	3.78	7.41	
12"	13.69	19.35	2.68	5.34	10.47	

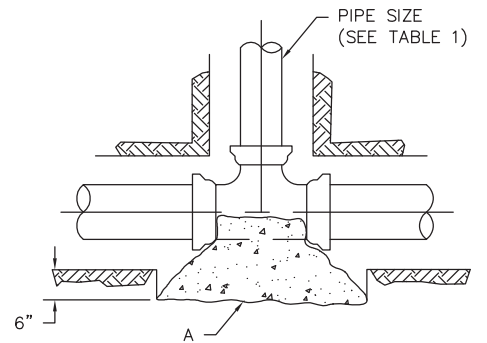

TEE
PLAN VIEW

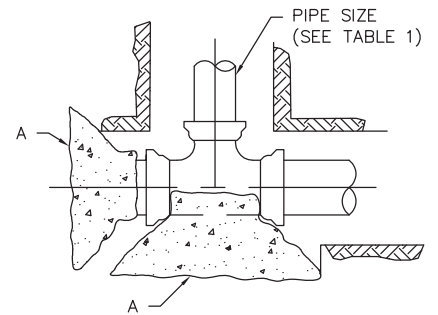

PLUGGED TEE
PLAN VIEW

APPROVED

3/8/23

DATE

DRAFT



CITY OF
PITTSBURGH

NO.	DATE	REVISION	DRAWN BY:	BJR
			CHECKED BY:	MK
			DATE:	2019-01-11
			SCALE:	NTS

STANDARD DETAIL

CONCRETE THRUST BLOCKING

SHEET 1 OF 3

W-10

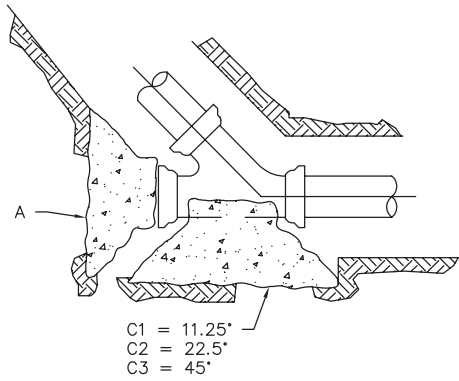

C1 = 11.25°
C2 = 22.5°
C3 = 45°

PLUGGED WYE
PLAN VIEW

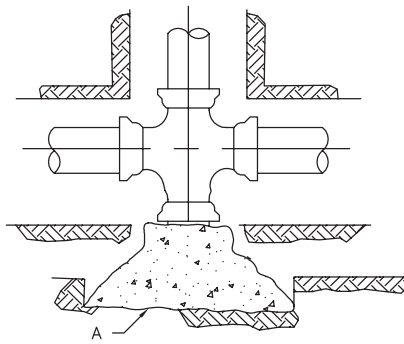

PLUGGED CROSS
PLAN VIEW

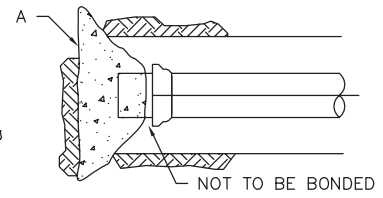

PLUGGED END
PLAN VIEW

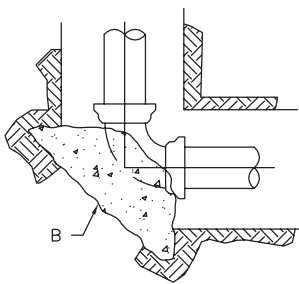

HORIZONTAL 90° (ELBOW)
PLAN VIEW

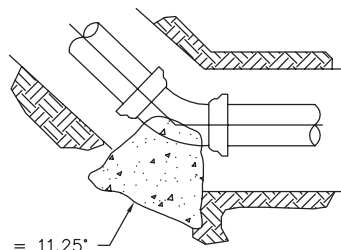

C1 = 11.25°
C2 = 22.5°
C3 = 45°

HORIZONTAL (ELBOW)
PLAN VIEW

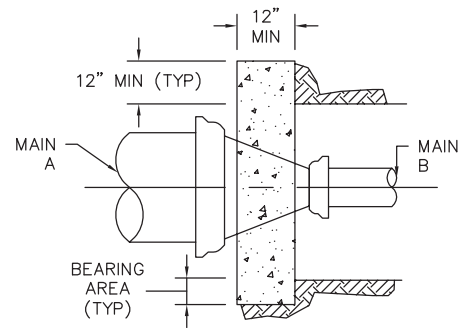

REDUCER
PLAN VIEW

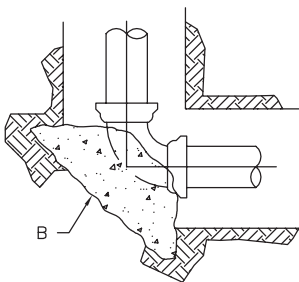

VERTICAL 90° (ELBOW)
PROFILE VIEW

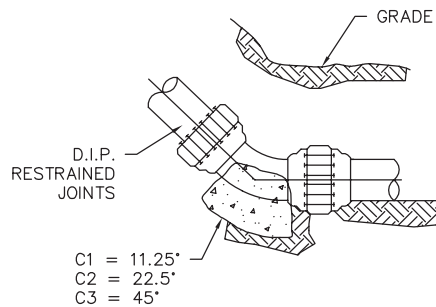

VERTICAL UNDERBEND
PROFILE VIEW

NOTES

1. FOR GENERAL NOTES AND THRUST BLOCK TABLES, SEE SHEET 1.

APPROVED

3/8/23

DATE

DRAFT



CITY OF
PITTSBURG

NO.	DATE	REVISION	DRAWN BY:
			BJR
			CHECKED BY: MK
			DATE: 2019-01-11
			SCALE: NTS

STANDARD DETAIL

CONCRETE THRUST BLOCKING

SHEET 2 OF 3

W-10

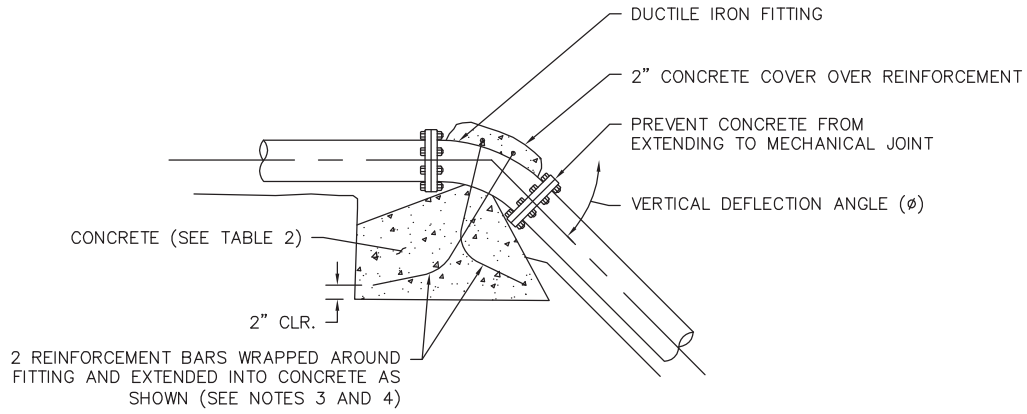

UPWARD FORCE VERTICAL BEND
PROFILE VIEW

PIPE SIZE	VERTICAL DEFLECTION ANGLE (ϕ)			
	11 $\frac{1}{2}$ '	22 $\frac{1}{2}$ '	45°	90°
6"	0.31	0.60	1.11	1.57
8"	0.54	1.07	1.97	2.79
12"	1.23	2.40	4.44	6.28

VOLUMES GIVEN ARE FOR A MAXIMUM TEST PRESSURE OF 150 PSI. VOLUMES SHOULD BE ADJUSTED FOR HIGHER PRESSURES SUBJECT TO APPROVAL OF THE DIRECTOR OF PUBLIC WORKS.

NOTES

- THRUST BLOCKS TO BE POURED AGAINST UNDISTURBED SOIL.
- VOLUME OF THRUST BLOCKS IN TABLE 2 FROM FORMULA:

$$V = \frac{1.5 PA (\sin \phi)}{4050}$$

WHERE: P = 150 PSI
 A = CROSS SECTIONAL AREA (SQUARE INCHES) OF THE PIPE USING THE OUTSIDE DIAMETER OF THE PIPE
- REINFORCEMENT BAR SIZE SHALL BE:
 #4 FOR VOLUME OF THRUST BLOCK < 2.4 C.Y.
 #5 FOR VOLUME OF THRUST BLOCK BETWEEN 2.4 & 4.4 C.Y.
 #6 FOR VOLUME OF THRUST BLOCK BETWEEN 4.4 & 6.8 C.Y.
- REINFORCEMENT BARS SHALL BE PLACED TO HAVE A 2" CLEARANCE FROM OUTSIDE EDGE OF CONCRETE.
- THRUST BLOCKS SHALL BE ELIMINATED IF A RESTRAINED JOINT DESIGN IS INCLUDED FOR THE PIPING, JOINTS, AND FITTINGS.
- CONCRETE SHALL BE PORTLAND CEMENT CONCRETE WITH A MINIMUM STRENGTH OF 4,000 PSI.

APPROVED _____

3/8/23

DATE

DRAFT



CITY OF PITTSBURGH

NO.	DATE	REVISION	DRAWN BY:	BJR
			CHECKED BY:	MK
			DATE:	2019-01-11
			SCALE:	NTS

STANDARD DETAIL
 CONCRETE THRUST BLOCKING FOR
 UPWARD FORCE VERTICAL WATER
 LINE BENDS

SHEET 3 OF 3

W-10

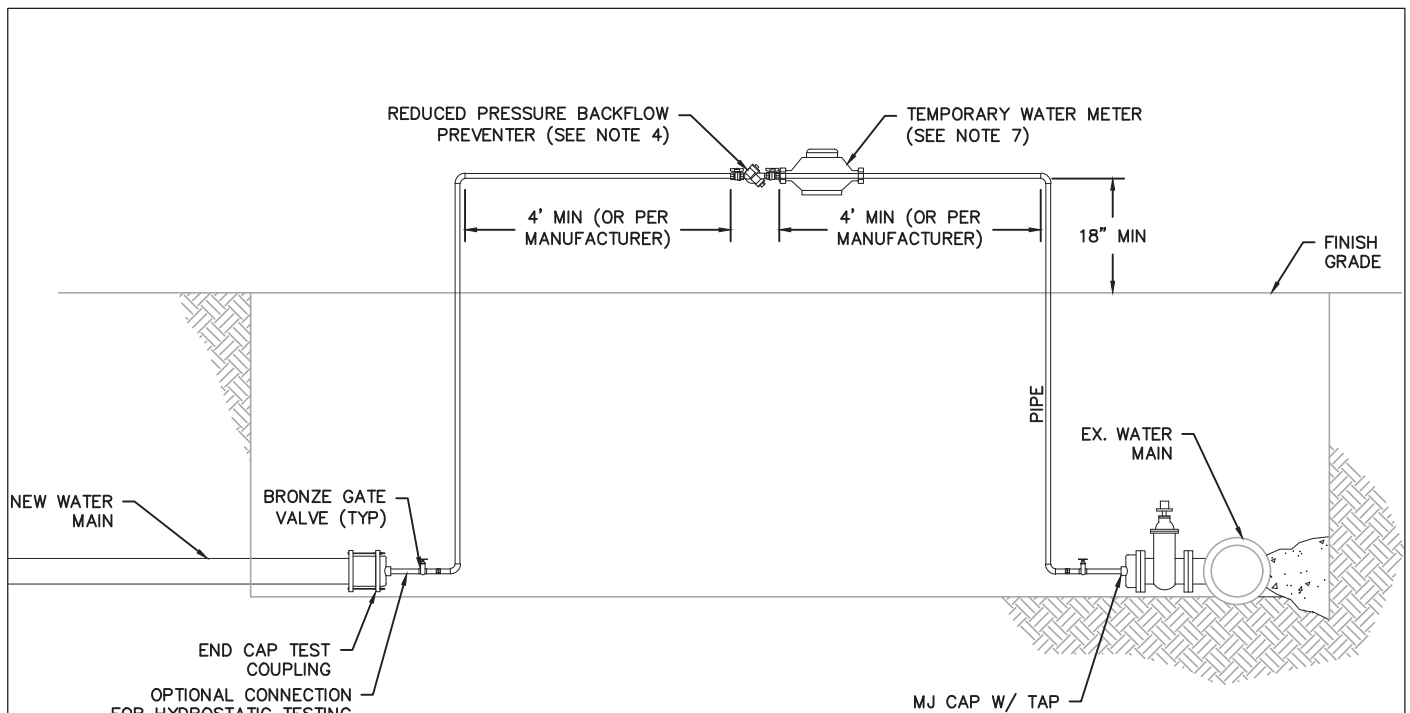

SECTION VIEW
SCALE: NTS

NOTES:

1. THE TEMPORARY FLUSHING AND TESTING CONNECTION SHOWN HERE IS TO BE USED IN LIEU OF AWWA C-651, FIGURE 1. THE USE OF BACKFLOW PROTECTION IS MANDATORY. THE TEMPORARY CONNECTION SHALL BE ADEQUATELY SIZED TO PROVIDE THE REQUIRED FLOW PER AWWA C-651 TO FLUSH PIPE.
2. THE BACKFLOW PREVENTION DEVICE SHALL BE TESTED BY THE CITY OF PITTSBURG AFTER INSTALLATION AND PRIOR TO THE COMMENCING OF ANY FLUSHING OR TESTING OF THE NEW WATER MAIN.
3. THE NEW WATER MAIN SHALL BE KEPT ISOLATED FROM THE ACTIVE DISTRIBUTION SYSTEM UNTIL SATISFACTORY BACTERIOLOGICAL TESTING HAS BEEN COMPLETED AND DISINFECTANT WATER FLUSHED OUT.
4. WHEN BACKFLOW PREVENTER IS LOCATED IN THE ROADWAY, CONTRACTOR SHALL PROVIDE TRAFFIC CONTROL; AS REQUIRED BY CITY, UNTIL COMPLETION OF ALL FLUSHING AND TESTING.
5. IF FOR ANY REASON, IT IS NECESSARY TO REMOVE THE TEMPORARY CONNECTION PRIOR TO THE SATISFACTORY COMPLETION OF FLUSHING AND TESTING, THEN PRIOR TO THE RESUMPTION OF FLUSHING AND TESTING THE CONNECTION ASSEMBLY SHALL BE DISINFECTED PER THE REQUIREMENTS OF AWWA C-651. CITY SHALL RETEST THE BACKFLOW PREVENTER.
6. PROTECT THE INSTALLATION OF THE BACKFLOW DEVICE TO PREVENT DAMAGE THAT MAY LEAD TO MALFUNCTION OF THE DEVICE. PROPER STORAGE AND HANDLING OF THE DEVICE WILL HELP PREVENT DIRT, ROCK OR OTHER DELETERIOUS MATERIAL FROM ENTERING OPEN ENDS OF THE BACKFLOW DEVICE.
7. CONTRACTOR SHALL INSTALL A TEMPORARY WATER METER UPSTREAM FROM THE BACKFLOW PREVENTION DEVICE. FOR SUBDIVISIONS, WATER METER SHALL BE ON BACKFLOW PREVENTION DEVICE. CITY TO PROVIDE WATER METER.
8. THE DESINFECTATION OF A NEW POTABLE WATER PIPING SYSTEM SHALL BE AS SPECIFIED IN SECTION 33 13 00 - DISINFECTING OF WATER DISTRIBUTION, OF THE CITY OF PITTSBURG STANDARD SPECIFICATIONS.
9. NEW WATER MAINS AND NEW SUPPLY LINES SHALL NOT BE INSTALLED IN THE SAME TRENCH AS, AND SHALL BE AT LEAST 10 FEET HORIZONTALLY FROM AND ONE FOOT VERTICALLY ABOVE, ANY PARALLEL PIPELINE CONVEYING SANITARY SEWER RECYCLED WATER OR FUEL LINES
10. NEW WATER MAINS AND NEW SUPPLY LINES SHALL BE AT LEAST 4 FEET HORIZONTALLY FROM AND ONE FOOT VERTICALLY ABOVE, ANY PARALLEL PIPELINE CONVEYING STORM DRAINAGE AND DISINFECTED TERTIARY RECYCLED WATER
11. IF CROSSING A PIPELINE CONVEYING A FLUID LISTED IN SECTIONS 8 AND 9 ABOVE, A NEW WATER MAIN SHALL BE CONSTRUCTED NO LESS THAN 45-DEGREES TO AND AT LEAST ONE FOOT ABOVE THE PIPELINE.

APPROVED

3/8/23

DATE

SHEET 1 OF 2



NO.	DATE	REVISION	DRAWN BY:	BJR
			CHECKED BY:	MK
			DATE:	2019-01-11
			SCALE:	NTS

STANDARD DETAIL
TEMPORARY FLUSHING AND TESTING CONNECTIONS

W-11

PRESSURE TEST SHALL BE IN ACCORDANCE WITH AWWA C600 AND THE FOLLOWING:

1. TEST PRESSURE: NOT LESS THAN 200 PSIG OR 50 PSI IN EXCESS OF MAXIMUM STATIC PRESSURE, WHICHEVER IS GREATER. THE TESTS SHALL BE PERFORMED AT AMBIENT TEMPERATURE UNLESS OTHERWISE SPECIFIED.
2. PREPARATION OF TEST:
 - a. VENTS SHALL BE AT THE HIGH POINTS OF THE SYSTEM AND DRAINS PROVIDED WHERE MEANS OF VENTING OR DRAINING DO NOT EXIST.
 - b. REMOVE OR BLOCK OFF, ALL RELIEF VALVES, RUPTURE DISCS, ALARMS, CONTROL INSTRUMENTS, ETC. THAT SHALL NOT BE SUBJECTED TO THE TEST PRESSURE. ALL GAGES USED IN THE SYSTEM SHALL BE CALIBRATED GAGES.
 - c. ALL DISCS, BALLS, OR PISTONS FROM CHECK VALVES SHALL BE REMOVED IF THEY INTERFERE WITH FILLING THE SYSTEM. OPEN ALL VALVES BETWEEN INLET AND OUTLET OF THE SECTION TO BE TESTED.
 - d. CONNECT PUMP AND PROVIDE TEMPORARY CLOSURES FOR ALL THE EXTERNAL OPENINGS IN THE SYSTEM. USE CAUTION TO INSURE THAT THE CLOSURES ARE PROPERLY DESIGNED AND STRONG ENOUGH TO WITHSTAND THE TEST PRESSURE.
 - e. A JOINT PREVIOUSLY TESTED IN ACCORDANCE WITH THIS SPECIFICATION MAY BE COVERED OR INSULATED.
 - f. EXPANSION JOINTS SHALL BE PROVIDED WITH TEMPORARY RESTRAINT FOR ADDITIONAL PRESSURE UNDER TEST OR SHALL BE ISOLATED FROM THE TEST.
 - g. FLANGED JOINTS, WHERE BLANKS ARE INSERTED TO ISOLATE EQUIPMENT DURING THE TEST, NEED NOT BE TESTED.
 - h. ALL CONCRETE BLOCK SHALL BE ALLOWED TO CURE A SUFFICIENT TIME TO DEVELOP THE MINIMUM COMPRESSIVE STRENGTH BEFORE TESTING.
 - i. PRESSURE TESTS ON EXPOSED AND ABOVE GROUND PIPING SHALL BE CONDUCTED ONLY AFTER THE ENTIRE PIPING SYSTEMS HAS BEEN INSTALLED AND ATTACHED TO THE PIPE SUPPORTS, HANGERS OR ANCHORS OR AS SHOWN ON THE PLANS.
 - j. ANY CONNECTION BETWEEN THE NEW PIPELINE BEING INSTALLED AND THE EXISTING WATER SYSTEM SHALL INCLUDE A STATE APPROVED REDUCED PRESSURE BACKFLOW ASSEMBLY INSTALLED TO PREVENT FLOW INTO THE EXISTING SYSTEM. THE BACKFLOW DEVICE ASSEMBLY SHALL BE REQUIRED UNTIL BACTERIOLOGICAL SAMPLING PROVES THE NEW PIPELINE IS PROPERLY DISINFECTED.
 - k. CONTRACTOR SHALL DISCONNECT SYSTEM FROM THE PUMP PRIOR TO VERIFYING THE DROP IN PRESSURE.
3. THE CONTRACTOR SHALL PAY COSTS OF ALL WATER USED FOR CONSTRUCTION PURPOSES, INCLUDING FLUSHING AND TESTING. THE CITY, AT HIS EXPENSE, SHALL PROVIDE A METER APPROVED BY THE PROJECT MANAGER TO COMPLETE THE WORK.
4. THE CONTRACTOR SHALL FURNISH ALL REQUIRED EQUIPMENT, PUMPS, CALIBRATED GAGES AND MATERIALS, MAKE ALL CONNECTIONS AND PERFORM THE REQUIRED TESTS.
5. CONDUCT HYDROSTATIC TEST FOR AT LEAST TWO HOURS. APPLY THE HYDROSTATIC TEST PRESSURE IN INCREMENTS OF 25 PSIG, OR AS DIRECTED BY THE PROJECT MANAGER UNTIL THE MAXIMUM TEST PRESSURE IS REACHED. HOLD PRESSURE FOR 5 MINUTES AT EACH 25 PSIG INCREMENT AND INSPECT FOR LEAKS BEFORE ADDING MORE PRESSURE.
6. SLOWLY FILL SECTION TO BE TESTED WITH WATER; EXPEL AIR FROM PIPING AT HIGH POINTS USING THE VENTS. PRIOR TO BEGINNING HYDROSTATIC TESTING, THE PIPELINE SHALL HAVE BEEN FILLED WITH WATER AND ALLOWED TO STAND A MINIMUM OF FOUR (4) HOURS UNDER A SLIGHT PRESSURE. INSTALL CORPORATION COCKS AT HIGH POINTS. CLOSE AIR VENTS AND CORPORATION COCKS AFTER AIR IS EXPELLED. RAISE PRESSURE SLOWLY WITH THE PUMP TO SPECIFIED TEST PRESSURE.
7. MAINTAIN PRESSURE FOR FOUR (4) HOURS KEEPING PERSONNEL AT A SAFE DISTANCE.
8. OBSERVE JOINTS, FITTINGS, AND VALVES UNDER TEST. REMOVE AND RENEW CRACKED PIPES, JOINTS, FITTINGS, AND VALVES SHOWING VISIBLE LEAKAGE. RETEST.
9. CORRECT VISIBLE DEFICIENCIES BY RELEASING THE PRESSURE, DRAINING THE SYSTEM AND CONTINUE TESTING AT SAME TEST PRESSURE FOR ADDITIONAL TWO HOURS TO DETERMINE ANY LEAKAGE. MAINTAIN PRESSURE WITHIN PLUS OR MINUS 5 PSI OF TEST PRESSURE.
10. DURING HYDROSTATIC TESTING, THE CONTRACTOR SHALL PROVIDE FOR TEMPORARY BLOCKING OF THE PIPELINE AT THE TIE-IN POINTS OR AS DIRECTED BY THE PROJECT MANAGER. NO HYDROSTATIC TEST WILL BE ALLOWED AGAINST A CLOSED VALVE CONNECTED TO THE EXISTING SYSTEM EXCEPT UNDER SPECIFIC SUPERVISED CONDITIONS APPROVED BY THE PROJECT MANAGER.
11. NO LEAKAGE IS ALLOWED.
12. IF TEST OF PIPE INDICATES LEAKAGE, LOCATE SOURCE OF LEAKAGE, MAKE CORRECTIONS, AND RETEST UNTIL THERE IS NO LEAKAGE IN THE SYSTEM
13. AFTER HYDROSTATIC TEST IS COMPLETE, REMOVE THE PRESSURE WITH CAUTION TO AVOID ESCAPING FLUID AND DEBRIS.

APPROVED



3/8/23

DATE

SHEET 2 OF 2

W-11



NO.	DATE	REVISION	DRAWN BY:	BJR
			CHECKED BY:	MK
			DATE:	2019-01-11
			SCALE:	NTS

STANDARD DETAIL
TEMPORARY FLUSHING AND TESTING CONNECTIONS

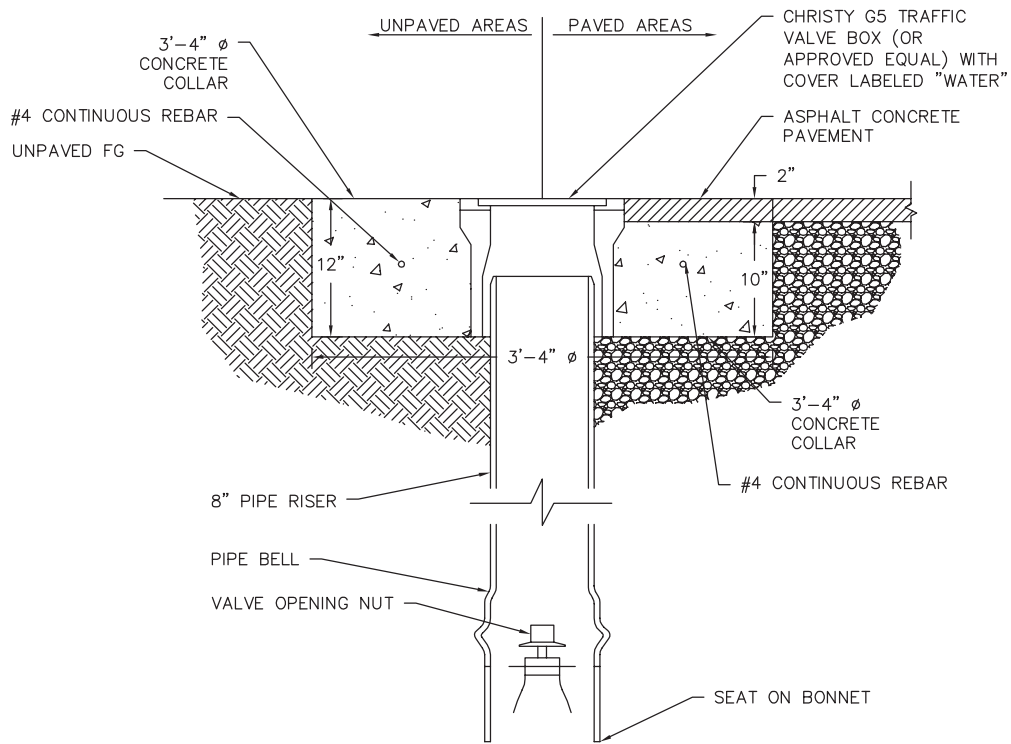

SECTION VIEW
SCALE: NTS

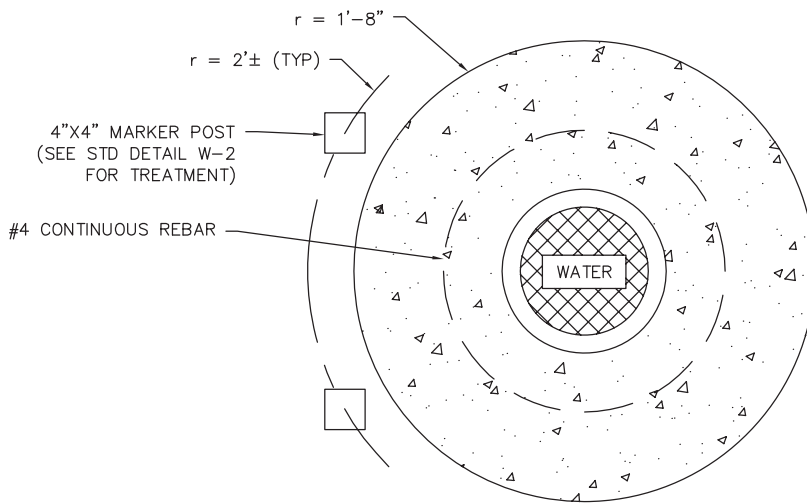

PLAN VIEW
SCALE: NTS

APPROVED

3/8/23

DATE

DRAFT



CITY OF
PITTSBURG

NO.	DATE	REVISION	DRAWN BY:	BJR
1	2019-01-11	SEAT ON BONNET	CHECKED BY:	MK
			DATE:	2019-01-11
			SCALE:	NTS

STANDARD DETAIL

WATER VALVE BOX INSTALLATION

SHEET 1 OF 1

W-12

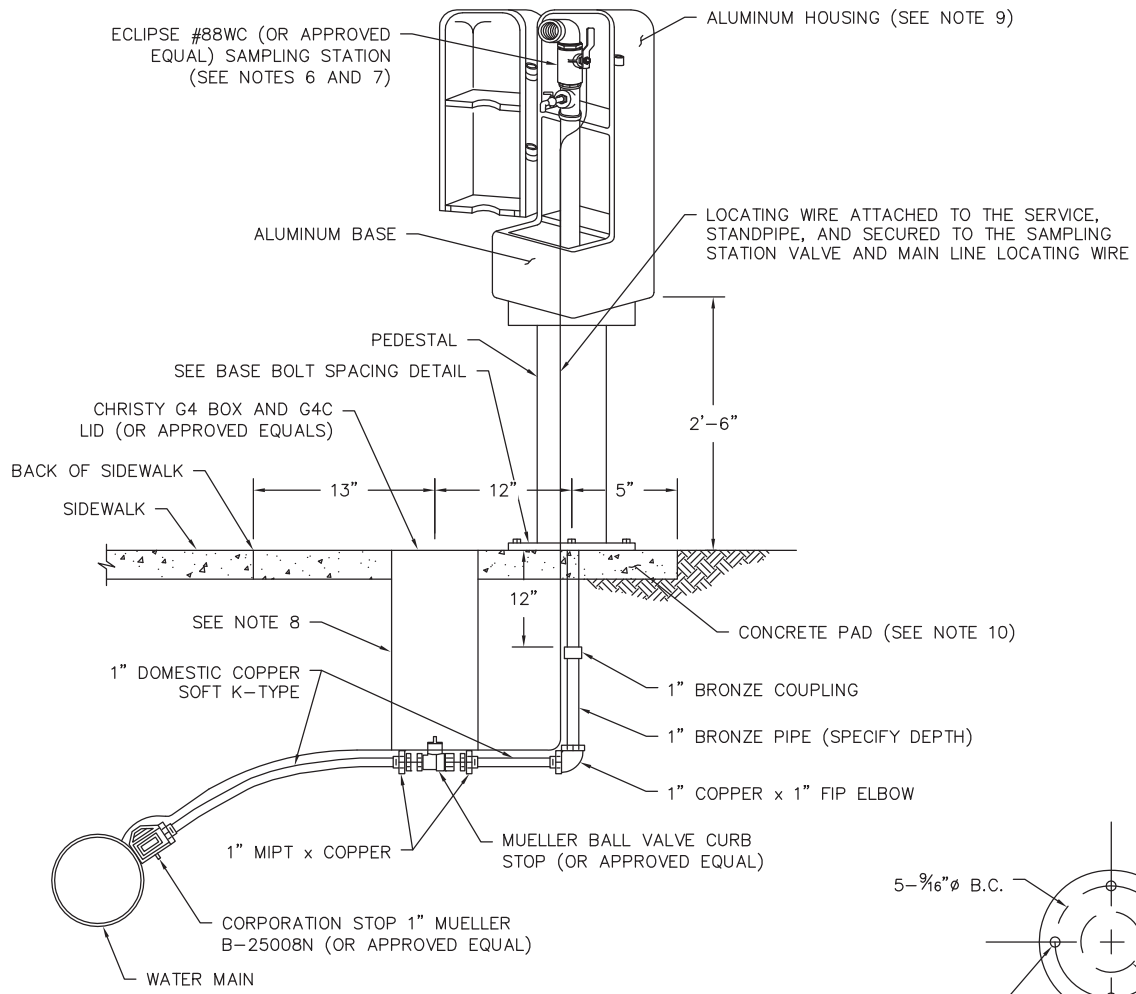

SECTION VIEW
SCALE: NTS

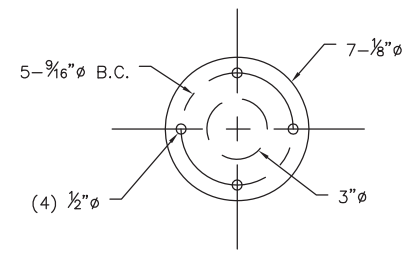

BASE BOLT SPACING
PLAN VIEW

NOTES

1. SAMPLING STATIONS SHALL BE 1' BURY, WITH A 1" MIP INLET, AND A 1" FIP DISCHARGE. A 1/4" BENT-NOSE SAMPLING BIB SHALL BE LOCATED BEFORE THE DISCHARGE.
2. ALL STATIONS SHALL BE ENCLOSED IN A LOCKABLE, NON-REMOVABLE, ALUMINUM-CAST HOUSING. HOUSING SHALL BE ON A 2'-6" PEDESTAL WITH A 7-1/8" MOUNTING FLANGE.
3. WHEN OPENED, THE STATION SHALL REQUIRE NO KEY FOR OPERATION, AND THE WATER WILL FLOW IN AN ALL BRASS WATERWAY.
4. ALL WORKING PARTS WILL BE OF BRONZE AND SERVICEABLE FROM ABOVE GROUND WITH NO DIGGING.
5. A 1" BALL VALVE WILL CONTROL THE WATER FLOW, AND BE LOCATED BEFORE (OR AFTER) THE SAMPLING BBB, AS MANUFACTURED BY KUPFERLE FOUNDRY, ST. LOUIS, MO 63102 (OR APPROVED EQUAL).
6. LOCATE SAMPLING STATION ASSEMBLY AT BACK OF SIDEWALK AND ALUMINUM HOUSING DOOR FACING THE SIDEWALK.
7. ECLIPSE #88WC SAMPLING STATION IS FROM KUPFERLE FOUNDRY, ST. LOUIS, MO. 63102 (OR APPROVED EQUAL).
8. NOTCH BOTTOM OF VALVE RISER MATERIAL TO ACCOMMODATE THE SERVICE LINE AND LOCATING WIRE.
9. CAST CITY OF PITTSBURG LOGO INTO SAMPLING STATION HOUSING DOOR.
10. PAD SHALL BE PORTLAND CEMENT CONCRETE, 4,000 PSI MINIMUM, 2'-6" x 2' x 4" THICK SLOPING AT 1/4" PER FOOT TOWARDS SIDEWALK.

APPROVED  DATE **3/8/23**

DRAFT



NO.	DATE	REVISION	DRAWN BY:	BJR
			CHECKED BY:	MK
			DATE:	2019-01-11
			SCALE:	NTS

STANDARD DETAIL
WATER QUALITY SAMPLING STATION

SHEET 1 OF 1
W-13

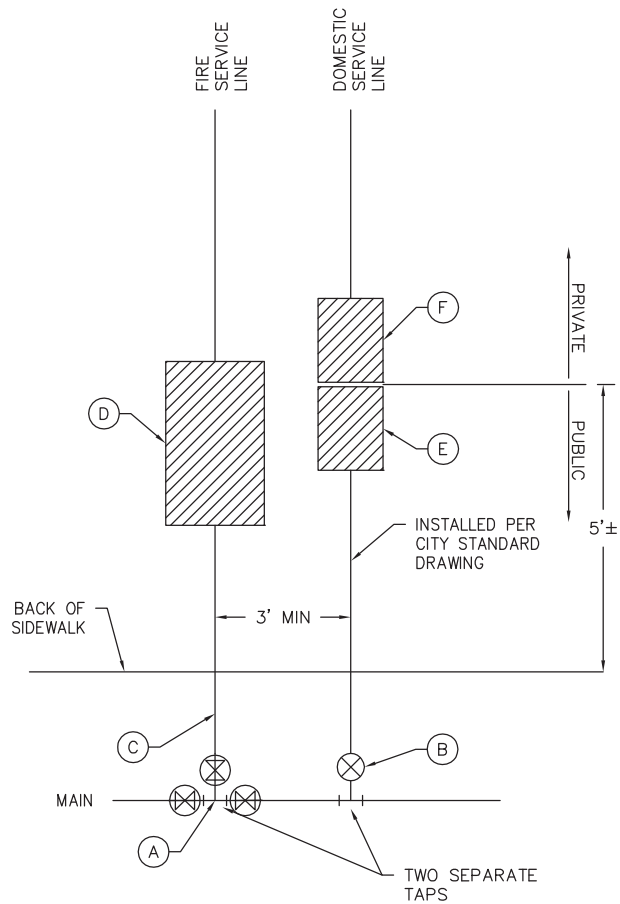

PLAN VIEW
SCALE: NTS

NOTES

1. ALL MATERIALS LISTED OR SHOWN SHALL BE FURNISHED AND INSTALLED BY THE CONTRACTOR UNLESS OTHERWISE NOTED.
2. DOUBLE CHECK DETECTOR VALVE ASSEMBLY AND WATER METER SHALL BE INSTALLED AS CLOSE TO BACK OF SIDEWALK AS POSSIBLE.
3. SEE CONTRA COSTA COUNTY FIRE DEPARTMENT FOR ADDITIONAL REQUIREMENTS. DESIGN AND INSTALLATION SUBJECT TO APPROVAL OF FIRE DEPARTMENT.

- (A) STAINLESS STEEL TAPPING SLEEVE: MUELLER, JCM, ROMAC, SMITH-BLAIR OR FLANGED TEE WITH 3 FLANGED VALVES. THE REQUIREMENT FOR CUTTING IN A TEE WILL BE DETERMINED ON AN INDIVIDUAL BASIS. INSTALLATION OF ADDITIONAL MAIN LINE VALVES WILL BE DETERMINED BY THE CITY.
- (B) MUELLER VALVE FLANGED BY MECHANICAL JOINT WITH OPERATING NUT (OR APPROVED EQUAL).
- (C) PRESSURE CLASS 350 D.I.P. SIZE TO BE DETERMINED BY THE DESIGN ENGINEER FROM FIRE AND DOMESTIC REQUIREMENTS. THE SIZE SHALL BE DESIGNATED ON THE CONSTRUCTION PLANS FOR APPROVAL BY THE CITY.
- (D) CITY APPROVED DOUBLE CHECK DETECTOR VALVE ASSEMBLY. SEE APPLICABLE STANDARD DRAWINGS.
- (E) WATER METER AND STRAINER FURNISHED AND MAINTAINED BY THE CITY.
- (F) REDUCED PRESSURE BACKFLOW PREVENTION ASSEMBLY. PRIVATELY MAINTAINED. SEE STD DETAIL W-6.

APPROVED _____

3/8/23

DATE

DRAFT



CITY OF
PITTSBURG

NO.	DATE	REVISION	DRAWN BY:
1	2019-01-11	NOTE 3	BJR
			CHECKED BY: MK
			DATE: 2019-01-11
			SCALE: NTS

STANDARD DETAIL

COMBINATION FIRE AND DOMESTIC
WATER SERVICE

SHEET 1 OF 1

W-14

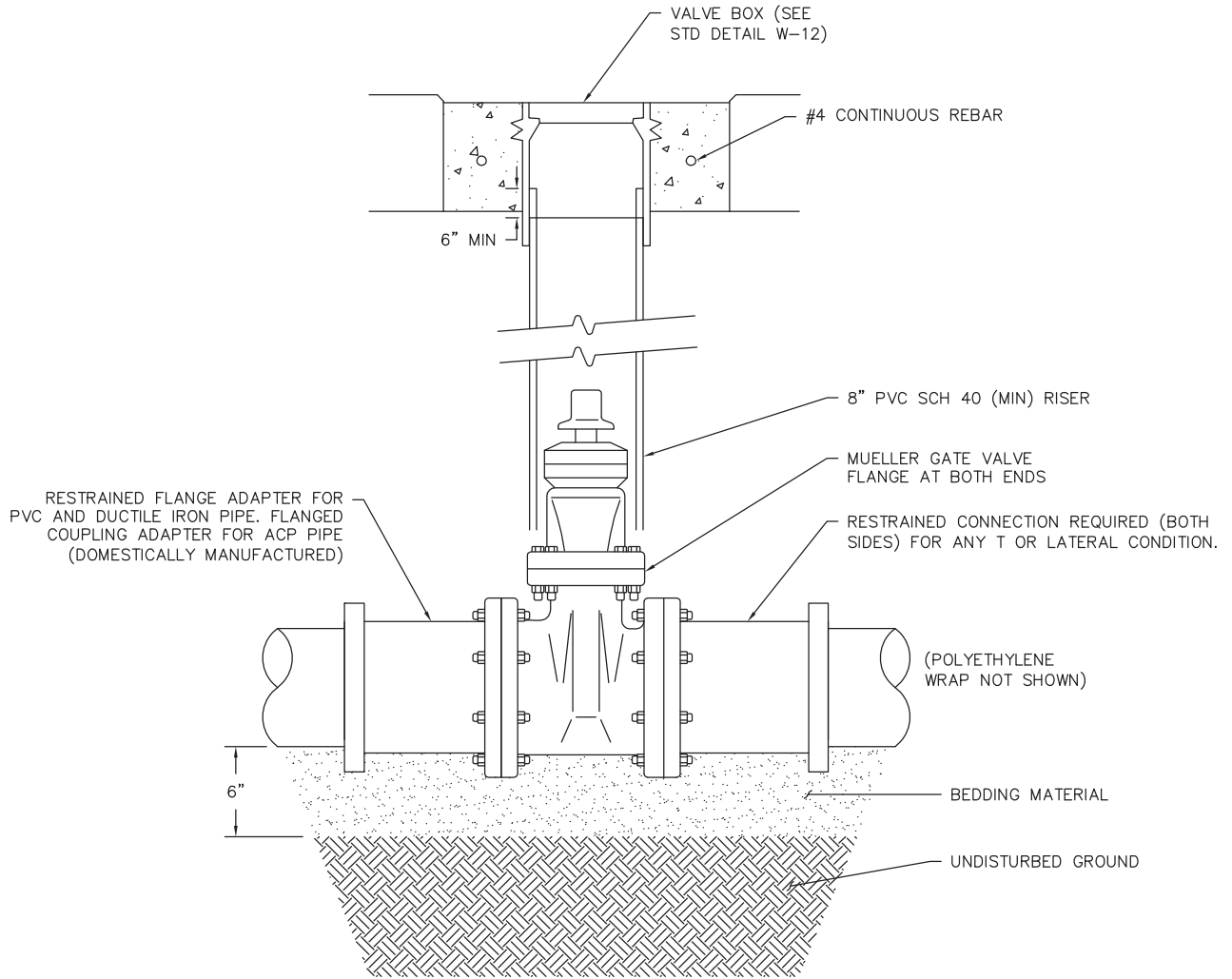

SECTION VIEW
SCALE: NTS

NOTES

1. GATE VALVES SHALL BE INSTALLED ON WATER MAINS OF 10" DIAMETER OR LESS. BUTTERFLY VALVES WILL BE INSTALLED ON WATER MAINS OF 12" OR LARGER.
2. INSTALL LOCATING WIRE AT THE VALVE LOCATION IN ACCORDANCE WITH STANDARD DETAIL W-17.
3. "CONCRETE" SHALL BE PORTLAND CEMENT CONCRETE WITH A MINIMUM STRENGTH OF 4,000 PSI.
4. ALL UNDERGROUND FLANGE BOLT ASSEMBLIES SHALL BE TYPE 316 STAINLESS STEEL WITH TEFLON ANTI-SEIZE COMPOUND.
5. MECHANICAL JOINT OKAY WITH MEGALUG.

APPROVED

3/8/23

DRAFT

DATE



CITY OF
PITTSBURGH

NO.	DATE	REVISION	DRAWN BY:
1	2019-01-11	NOTE 5	BJR
			CHECKED BY: MK
			DATE: 2019-01-11
			SCALE: NTS

STANDARD DETAIL

GATE WATER VALVE INSTALLATION

SHEET 1 OF 1

W-16

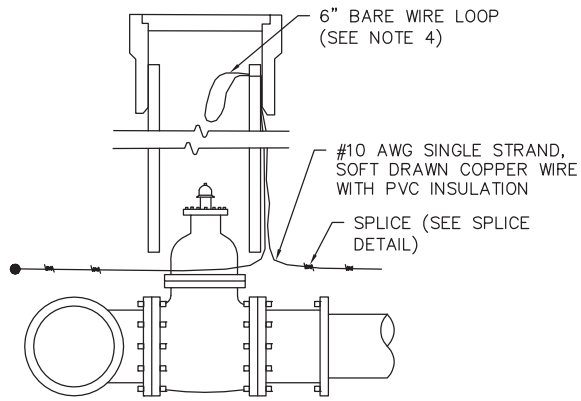

SECTION VIEW
SCALE: NTS

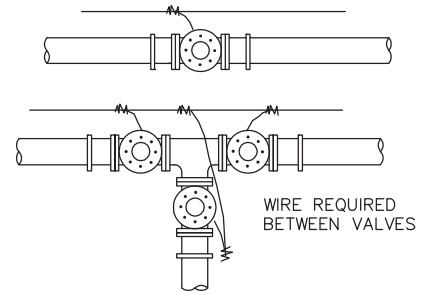

MAIN INTERSECTIONS
PLAN VIEW

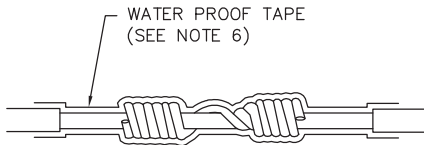

SPlice DETAIL

NOTES

1. WIRE SHALL BE CONTINUOUS BETWEEN VALVE BOXES ALONG THE MAIN LINE.
2. WIRE SHALL BE CONTINUOUS BETWEEN THE MAIN AND METER VALVE OR AIR RELEASE VALVE ON THE RELATED SERVICE LINE.
3. LOCATING WIRE TO BE LAID OVER TOP OF PIPE AND SECURED WITH TAPE AT EVERY 10' INTERVAL AND AT ELBOWS AND VALVES.
4. WIRE TO BE EXTENDED THROUGH NOTCH IN RISER AND WITHIN 6" MIN. OF VALVE BOX LID.
5. CONTRACTOR SHALL CONDUCT A CONTINUITY TEST ON ALL LOCATING WIRE SPLICES.
6. REMOVE INSULATION AT SPlice. INSURE CONTINUITY. WRAP SPlice WITH WATER-PROOF TAPE (SCOTCHKOTE ELECTRICAL COATING OR APPROVED EQUAL).

APPROVED

3/8/23

DATE

DRAFT



CITY OF
PITTSBURG

NO.	DATE	REVISION	DRAWN BY:	BJR
			CHECKED BY:	MK
			DATE:	2019-01-11
			SCALE:	NTS

STANDARD DETAIL

LOCATING WIRE INSTALLATION

SHEET 1 OF 1

W-17

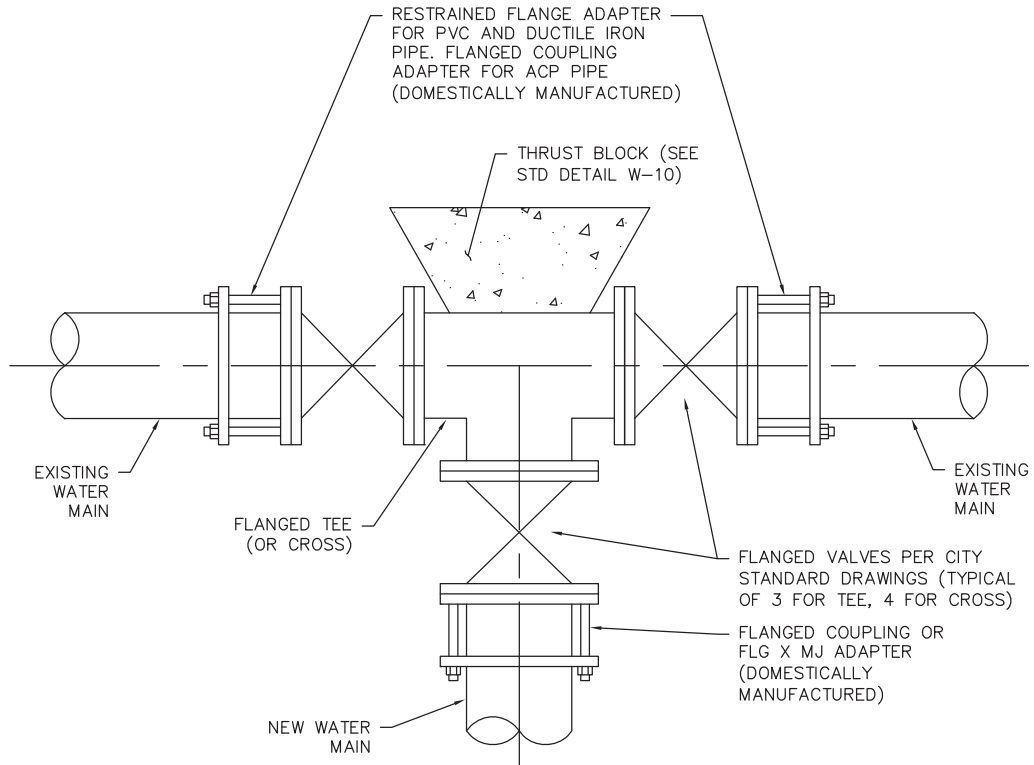

PLAN VIEW
SCALE: NTS

NOTES

1. EXISTING WATER MAIN MUST BE SHUT DOWN BY THE CITY AND DEWATERED BY THE CONTRACTOR. NOTIFICATION OF AFFECTED CUSTOMERS IS THE RESPONSIBILITY OF THE CONTRACTOR.
2. A GATE VALVE (OR BUTTERFLY VALVE FOR VALVES 12" OR LARGER) MUST BE INSTALLED ON EACH BRANCH OR RUN OF NEW TEE OR CROSS.
3. LOCATE ALL BUTTERFLY VALVE OPERATORS ON NORTH OR EAST SIDE OF PIPE.
4. PROVIDE THRUST BLOCK RESTRAINT PER STD DETAIL W-10.
5. INSTALL LOCATING WIRE AT VALVE LOCATIONS IN ACCORDANCE WITH STD DETAIL W-17.

APPROVED

3/8/23

DRAFT

DATE



CITY OF
PITTSBURGH

NO.	DATE	REVISION	DRAWN BY:	BJR
			CHECKED BY:	MK
			DATE:	2019-01-11
			SCALE:	NTS

STANDARD DETAIL

WATER MAIN CUT-IN

SHEET 1 OF 1

W-18

"X" = REFER TO DIMENSIONS ON CONSTRUCTION PLANS

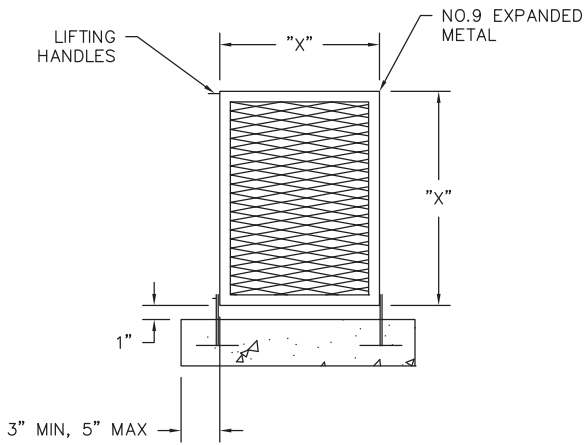

FRONT VIEW

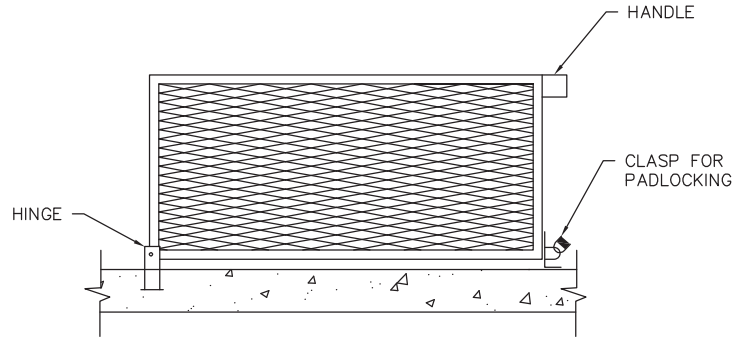

SIDE VIEW
3/4" TO 2" DEVICE

NOTES

1. REFER TO MANUFACTURER'S CATALOG FOR CORRECT DIMENSIONS TO FIT SIZE OF SPECIFIED BACKFLOW DEVICE.
2. CONCRETE FOUNDATION DIMENSIONS TO SUIT EACH INDIVIDUAL INSTALLATION, MINIMUM 4" THICK, OR AS PER MANUFACTURER'S RECOMMENDATION.
3. CONCRETE SHALL HAVE MINIMUM 28-DAY COMPRESSIVE STRENGTH OF 4,000 PSI.
4. PAINT ALL METAL SURFACES WITH RUST RESISTANT GLOSS ENAMEL PAINT (FOREST GREEN COLOR).

APPROVED

3/8/23

DATE

DRAFT



CITY OF PITTSBURGH

NO.	DATE	REVISION	DRAWN BY:	BJR
			CHECKED BY:	MK
			DATE:	2019-01-11
			SCALE:	NTS

STANDARD DETAIL

BACKFLOW ASSEMBLY CAGE

SHEET 1 OF 1

W-19

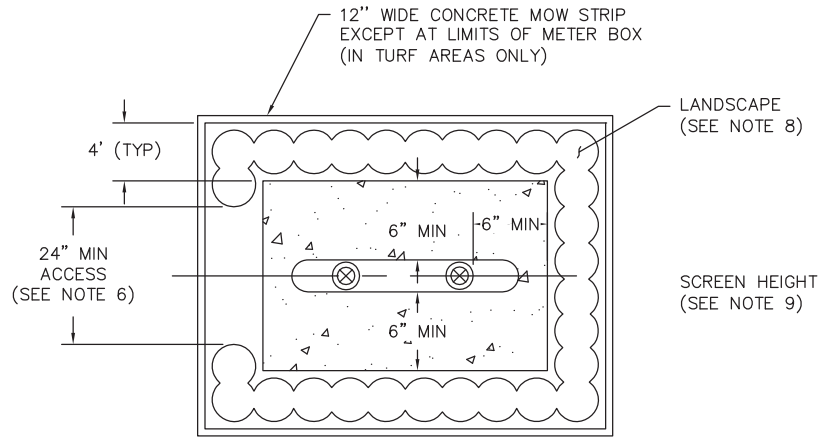

LANDSCAPE
PLAN VIEW

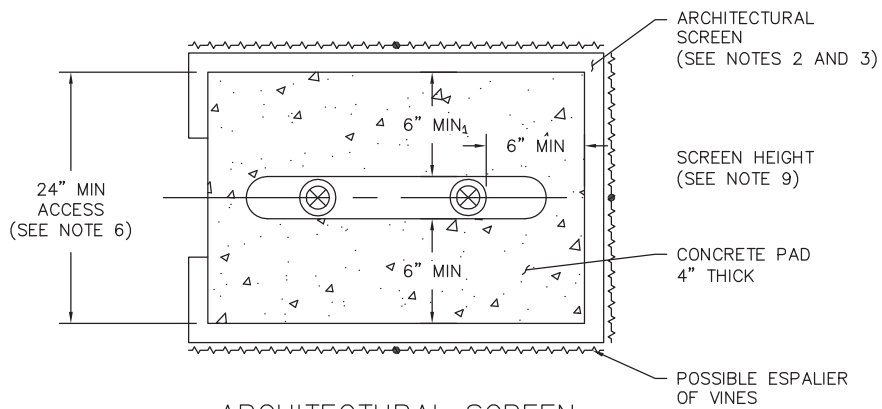

ARCHITECTURAL SCREEN
PLAN VIEW

NOTES

1. LANDSCAPING IS THE PREFERRED METHOD FOR SCREENING. ARCHITECTURAL SCREENING MATERIAL MAY BE USED ONLY IF THERE IS NOT ADEQUATE ROOM FOR LANDSCAPING AND IRRIGATION.
2. ARCHITECTURAL SCREENING, IF USED, SHALL BE MASONRY OR WOOD, AND SHALL MATCH ADJACENT ARCHITECTURE DESIGN, MATERIALS AND COLOR SHALL BE SUBJECT TO CITY APPROVAL.
3. IF A RETAINING WALL IS REQUIRED IN ORDER TO MEET MINIMUM CLEARANCE REQUIREMENTS AROUND DEVICE, LANDSCAPE SCREENING SHALL BE INCORPORATED ADJACENT TO THE WALL.
4. SIGHT DISTANCE CRITERIA MUST BE MET. FOR CRITERIA, SEE STANDARD DRAWINGS FOR "INTERSECTION STOPPING SIGHT DISTANCE".
5. SCREEN MAINTENANCE IS THE RESPONSIBILITY OF THE PROPERTY OWNER.
6. PROVIDE 24" MINIMUM VISUAL ACCESS FROM STREET FOR INSPECTION.
7. SCREENING MATERIAL (LANDSCAPE/ARCHITECTURAL) SHALL MAINTAIN A MINIMUM 6" CLEARANCE FROM ANY PART OF THE DEVICE TO LANDSCAPE OR SCREENING.
8. PLANT MATERIAL SHALL BE SELECTED FROM THE CITY'S APPROVED PLANT LIST (STD DETAIL L-4) AND AS APPROVED BY THE CITY ENGINEER.
9. MAXIMUM SCREEN HEIGHT OF 4' UNLESS SIGHT DISTANCE CRITERIA SPECIFIES OTHERWISE.

APPROVED

3/8/23

DATE

DRAFT



CITY OF
PITTSBURGH

NO.	DATE	REVISION	DRAWN BY:	BJR
			CHECKED BY:	MK
			DATE:	2019-01-11
			SCALE:	NTS

STANDARD DETAIL
SCREENING OF BACKFLOW
PREVENTER, DETECTOR CHECK
VALVE, AND BACKFLOW DEVICES

SHEET 1 OF 1

W-20

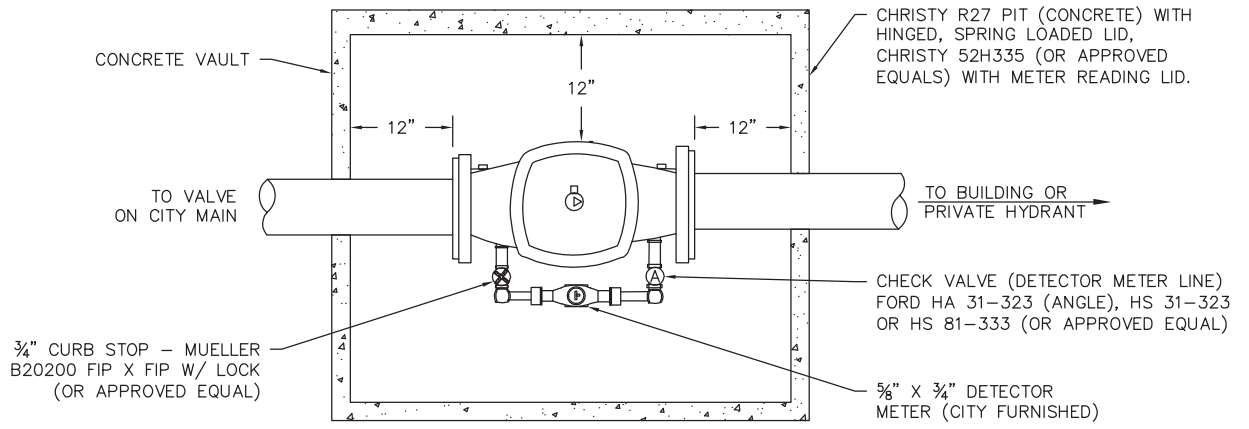

PLAN VIEW
SCALE: NTS

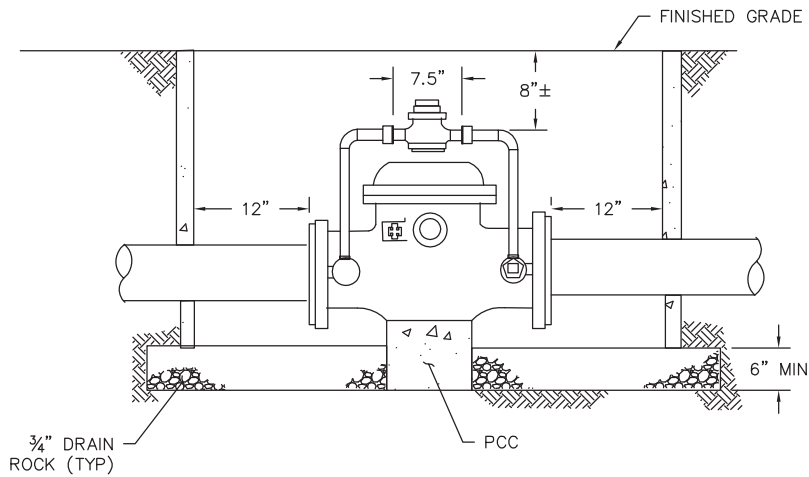

SECTION VIEW
SCALE: NTS

NOTES

1. SINGLE CHECK VALVE DETECTOR CHECK ASSEMBLY SHALL BE INSTALLED ON CLASS I AND II FIRE SERVICE AND PRIVATE FIRE HYDRANT LINE.
2. DETECTOR CHECK TO BE LOCATED WITHIN RIGHT OF WAY OR CITY EASEMENT.
3. VAULTS WILL NOT BE ALLOWED IN AREAS WHERE VAULT MIGHT BE SUBJECT TO VEHICULAR TRAFFIC.
4. DETECTOR METER, ONLY, TO BE FURNISHED BY CITY.
5. ALL TRIM MATERIALS TO BE BRASS/COPPER.

APPROVED _____

3/8/23

DATE

DRAFT



CITY OF
PITTSBURGH

NO.	DATE	REVISION	DRAWN BY:	BJR
			CHECKED BY:	MK
			DATE:	2019-01-11
			SCALE:	NTS

STANDARD DETAIL
SINGLE CHECK VALVE-DETECTOR
CHECK ASSEMBLY - INDUSTRIAL &
COMMERCIAL

SHEET 1 OF 1

W-22

ITEM	MANUFACTURER/MODEL (OR APPROVED EQUAL)
BACKFLOW PREVENTER	FEBCO MODEL 825Y
BACKFLOW PREVENTER ENCLOSURE	STRONG BOX MODEL SBBC-CR (POWDER COATED DARK GREEN)
BOOSTER PUMP	WATERTRONICS
PRESSURE REDUCING VALVE	WILKINS MODEL 600XL
MASTER VALVE	RAIN BIRD PESB SERIES
FLOW SENSOR	RAIN MASTER FM SERIES
GATE VALVE-4" & LARGER	NIBCO P-619-RW
GATE VALVE-3" & SMALLER	LEEMCO LGT-SS SERIES
QUICK COUPLING VALVE	RAIN BIRD 44LRC OR 44NP (RECYCLED WATER SYSTEMS)
CONTROLLER	SITE ONE GREEN TECH DX2 SATELLITE ASSEMBLY
ELECTRIC CONTROL VALVE	RAIN BIRD PEB SERIES
BRASS BALL VALVE	NIBCO T-FP-600A
VALVE BOXES IN PLANTING AREAS	CARSON MODEL 708,910,1419 OR 1324
POP-UP TURF SPRAY SPRINKLER	RAIN BIRD 1806-SAM-PRS SERIES
POP-UP SHRUB SPRAY SPRINKLER	RAIN BIRD 1812-SAM-PRS SERIES
POP-UP ROTOR SPRINKLER	RAIN BIRD 8005 OR 5000 SERIES
BUBBLER	RAIN BIRD 1400 SERIES
DRIPLINE	RAIN BIRD XFCV
INLINE CHECK VALVE	NDS CV SERIES

APPROVED



3/8/23

DATE

DRAFT



CITY OF PITTSBURGH

NO.	DATE	REVISION	DRAWN BY:
			CHECKED BY: MK
			DATE: 2019-01-11
			SCALE: NONE

STANDARD DETAIL

IRRIGATION EQUIPMENT LIST

SHEET 1 OF 1

I-1

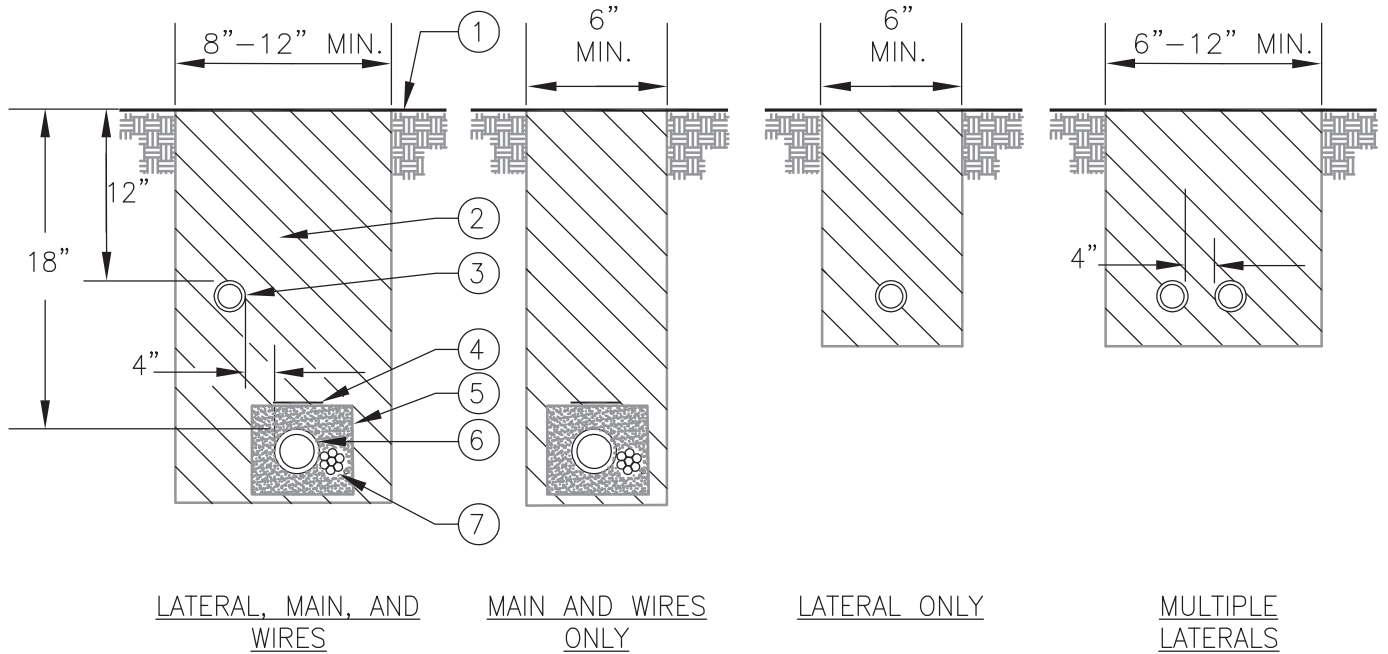

NOTES:

1. ALL MAIN SUPPLY LINES AND LATERAL LINES SHALL BE PLACED IN SLEEVES UNDER PAVED SURFACES. INSTALL LOW VOLTAGE WIRES WITHIN A SEPARATE CONDUIT UNDER PAVED SURFACES. DO NOT TAPE WIRES WITHIN CONDUIT
2. REUSE SALVAGED EXCAVATED FILL AND COMPACT TO ORIGINAL DENSITY IN LANDSCAPE AREAS. ALL OTHER AREAS SHALL BE AT 85% COMPACTION. BACKFILL MATERIAL SHALL BE THE EARTH EXCAVATED FROM THE TRENCHES, FREE FROM ROCKS (ANYTHING LARGER THAN 2"), CONCRETE CHUNKS, AND OTHER FOREIGN OR COARSE MATERIALS
3. FOR ANY PIPING UNDER PAVEMENT, SEE CITY DETAIL R-5.
4. WHEN 12" POP-UP SPRINKLER HEADS ARE USED, INCREASE THE DEPTH OF LATERAL TO 18" AT THE SPRINKLER LOCATION ONLY

- ① FINISH GRADE
- ② CLEAN BACKFILL MATERIAL
- ③ LATERAL LINE
- ④ 3" DETECTABLE WARNING TAPE OVER MAIN LINE. INSTALL ON TOP OF SAND ENCASUREMENT. USE CHRISTY MODEL #TA-DT-3-BIRR FOR POTABLE IRRIGATION SYSTEMS OR #TA-DT-3-PRW FOR RECYCLED IRRIGATION WATER SYSTEMS
- ⑤ ENCASE MAIN LINE AND WIRES IN SAND. PROVIDE 4" OF SAND ABOVE MAIN AND WIRES AND A MINIMUM OF 2" OF SAND ON THE REMAINING SIDES
- ⑥ MAIN LINE
- ⑦ LOW VOLTAGE CONTROL WIRES OR TWO-WIRE CABLE. TAPE AND BUNDLE CONTROL WIRES AT 10 FT. INTERVALS. WIRING SHALL BE LAID OUT LOOSELY IN THE TRENCH

APPROVED _____

3/8/23

DATE

DRAFT

	NO.	DATE	REVISION	DRAWN BY: CM	<u>STANDARD DETAIL</u> IRRIGATION SYSTEM TRENCHING	SHEET 1 OF 1 1-2
				CHECKED BY: MK		
				DATE: 2019-01-11		
				SCALE: NTS		

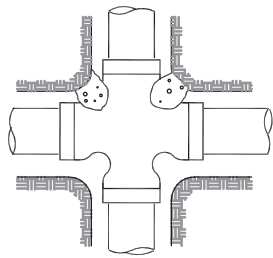

CROSS

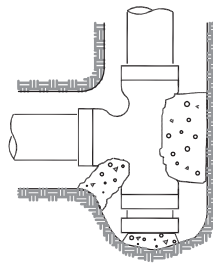

TEE W/ STUB

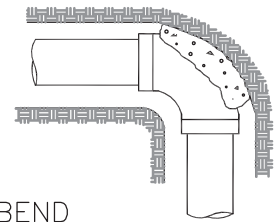

90° BEND

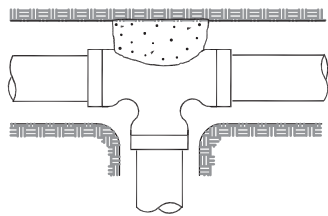

TEE

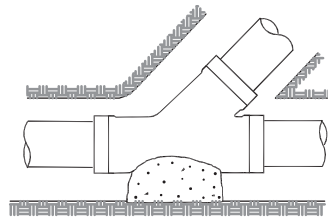

WYE

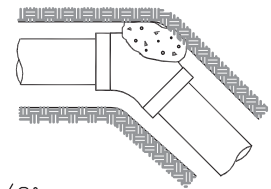

22 1/2°
OR 45° BEND

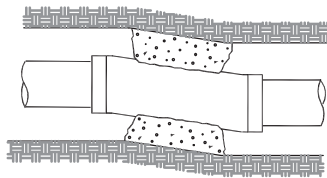

1 1/4° BEND

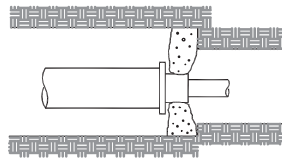

REDUCER



END CAP

1. CONCRETE THRUST BLOCK SHALL HAVE CONTACT WITH FITTING ONLY AND REMAIN CLEAR OF PIPE AND JOINTS
2. THRUST BLOCK TO BE CONSTRUCTED OF 3000 PSI CONCRETE
3. BLOCK TO BE POURED AGAINST UNDISTURBED SOIL
4. REFER TO CITY STANDARD DETAIL W-10 FOR THRUST BLOCK SIZING CHART

APPROVED

3/8/23

DRAFT

DATE



CITY OF
PITTSBURG

NO.	DATE	REVISION

DRAWN BY:	CM
CHECKED BY:	MK
DATE:	2019-01-11
SCALE:	NTS

STANDARD DETAIL
IRRIGATION SYSTEM THRUST
BLOCKING

SHEET 1 OF 1

I-3

NOTES:

1. PROVIDE (CONTRACTOR) #10 BARE COPPER GROUND WIRE AND 5/8" DIA. (8' LONG) COPPER CLAD GROUNDING ROD(S) AS DIRECTED BY MANUFACTURER
2. UNIT IS TO BE ASSEMBLED, WIRED, AND TESTED BY A MANUFACTURER TRAINED VENDOR.
3. INSTALL (CONTRACTOR) ENCLOSURE TO CONCRETE PAD AS DIRECTED BY ENCLOSURE MANUFACTURER
4. INSTALL SLAB LEVEL AND 1" ABOVE FINISH GRADE. PROVIDE SLOPE TO TOP OF SLAB SURFACE FOR DRAINAGE
5. CONTRACTOR IS RESPONSIBLE TO COORDINATE 120V POWER FOR CONTROLLER WITH CITY PRIOR TO INSTALLATION
6. CONTROLLER TO BE CERTIFIED BY GREEN TECH

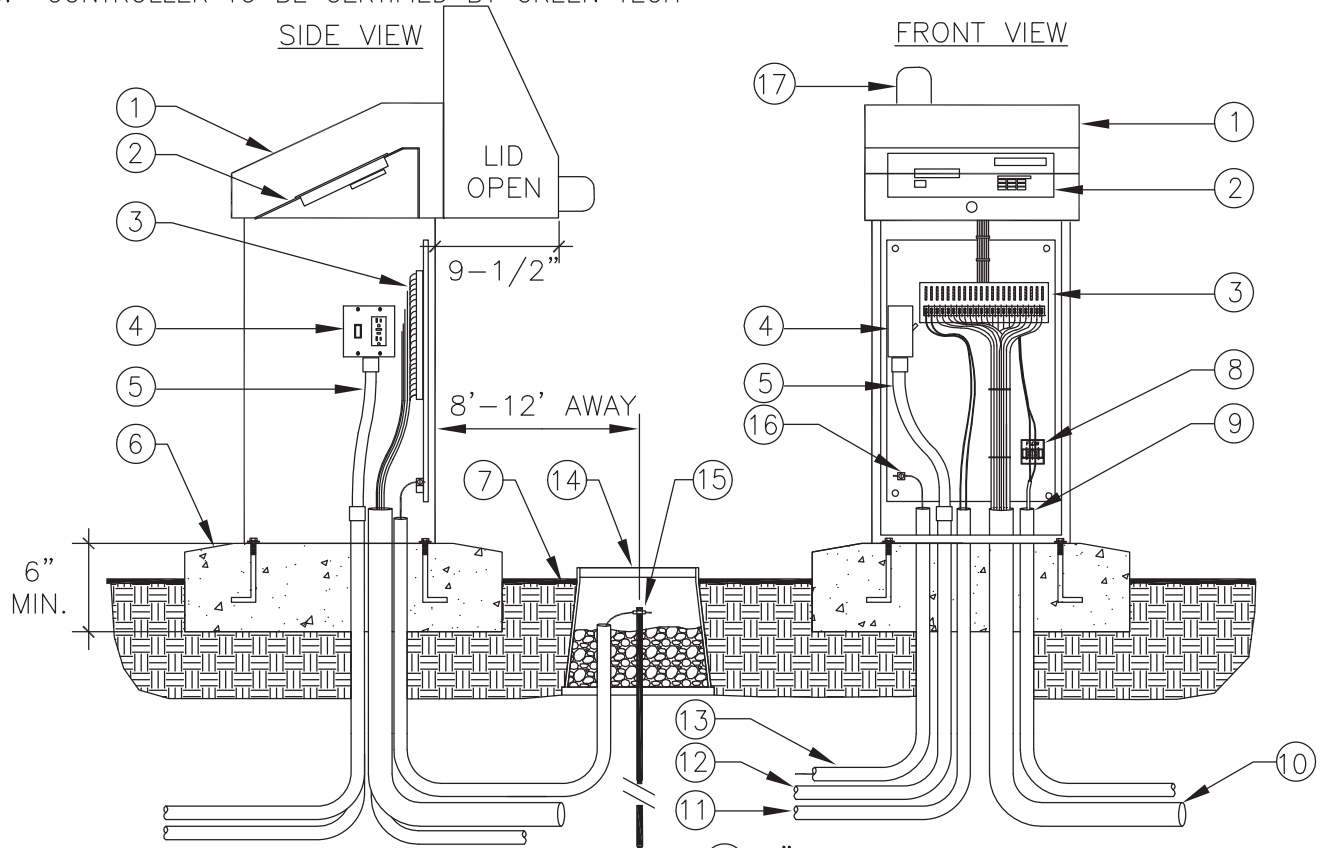

- | | |
|---|--|
| <ul style="list-style-type: none"> ① STRONGBOX STAINLESS STEEL NEMA 3R RAINPROOF ENCLOSURE (UL LISTED) ② SATELLITE ASSEMBLY. ASSEMBLED IN ENCLOSURE BY JOHN DEERE GREEN TECH ③ TERMINAL STRIP FOR VALVE WIRES ④ POWER SWITCH / GFCI RECEPTACLE ⑤ ELECTRICAL FLEX CONDUIT FOR POWER ⑥ 6" MIN THICK, CONCRETE PAD WITH ANCHOR BOLTS PER MANUFACTURER RECOMMENDATIONS ⑦ FINISH GRADE ⑧ FLOW SENSOR TERMINAL BOARD ⑨ 1" CONDUIT AND SWEEP ELL WITH FLOW SENSOR CABLE | <ul style="list-style-type: none"> ⑩ 3" CONDUIT AND SWEEP ELL FOR LOW VOLTAGE WIRES ⑪ 1" CONDUIT AND SWEEP ELL FOR MASTER VALVE WIRES ⑫ 1" CONDUIT AND SWEEP ELL FOR 110 VAC POWER LINE ⑬ 1" CONDUIT AND SWEEP ELL FOR GROUND WIRE ⑭ 10" ROUND VALVE BOX AROUND GROUND ROD. FILL WITH 3/4" CRUSHED ROCK ⑮ 5/8" X 8' GROUND ROD WITH #6 GROUND WIRE AND CLAMP. LOCATE 8'-12' FROM ENCLOSURE ⑯ #6 GROUND WIRE SECURED TO BACKBOARD GROUNDING TERMINAL ⑰ REMOTE RADIO ANTENNA |
|---|--|

APPROVED 3/8/23

DRAFT							
	CITY OF PITTSBURG	NO.	DATE	REVISION	DRAWN BY: CM	CHECKED BY: MK	DATE: 2019-01-11
					SCALE: NTS	STANDARD DETAIL	SHEET 1 OF 1
					CONTROLLER IN PEDESTAL ENCLOSURE		I-4

- ① HIGH GAIN ANTENNA
- ② ANTENNA MOUNTING ASSEMBLY
- ③ 10'-1.5" SCH 40 GALVANIZED STEEL POLE (TOP AND BOTTOM THREADED)
- ④ GALVANIZED COUPLING (1.5"). SET 4" ABOVE CONCRETE FOOTING
- ⑤ 2' x 2' x 2' CONCRETE FOOTING FOR GALVANIZED POLE
- ⑥ 18'-1.5" SCH 40 GALVANIZED STEEL POLE (TOP AND BOTTOM THREADED)
- ⑦ GALVANIZED COUPLING (1.5"). SET IN CONCRETE FOOTING
- ⑧ GALVANIZED SWEEP ELL. SET IN CONCRETE FOOTING
- ⑨ PVC FEMALE ADAPTER OR REDUCING BUSHING TO CONVERT FROM GALVANIZED TO 1.5" PVC CONDUIT
- ⑩ 1-1/2" PVC CONDUIT AND SWEEP ELL INTO IRRIGATION CONTROLLER
- ⑪ SATELLITE CONTROLLER ASSEMBLY

NOTE:
ANTENNA ASSEMBLY
TO BE CERTIFIED BY
GREEN TECH

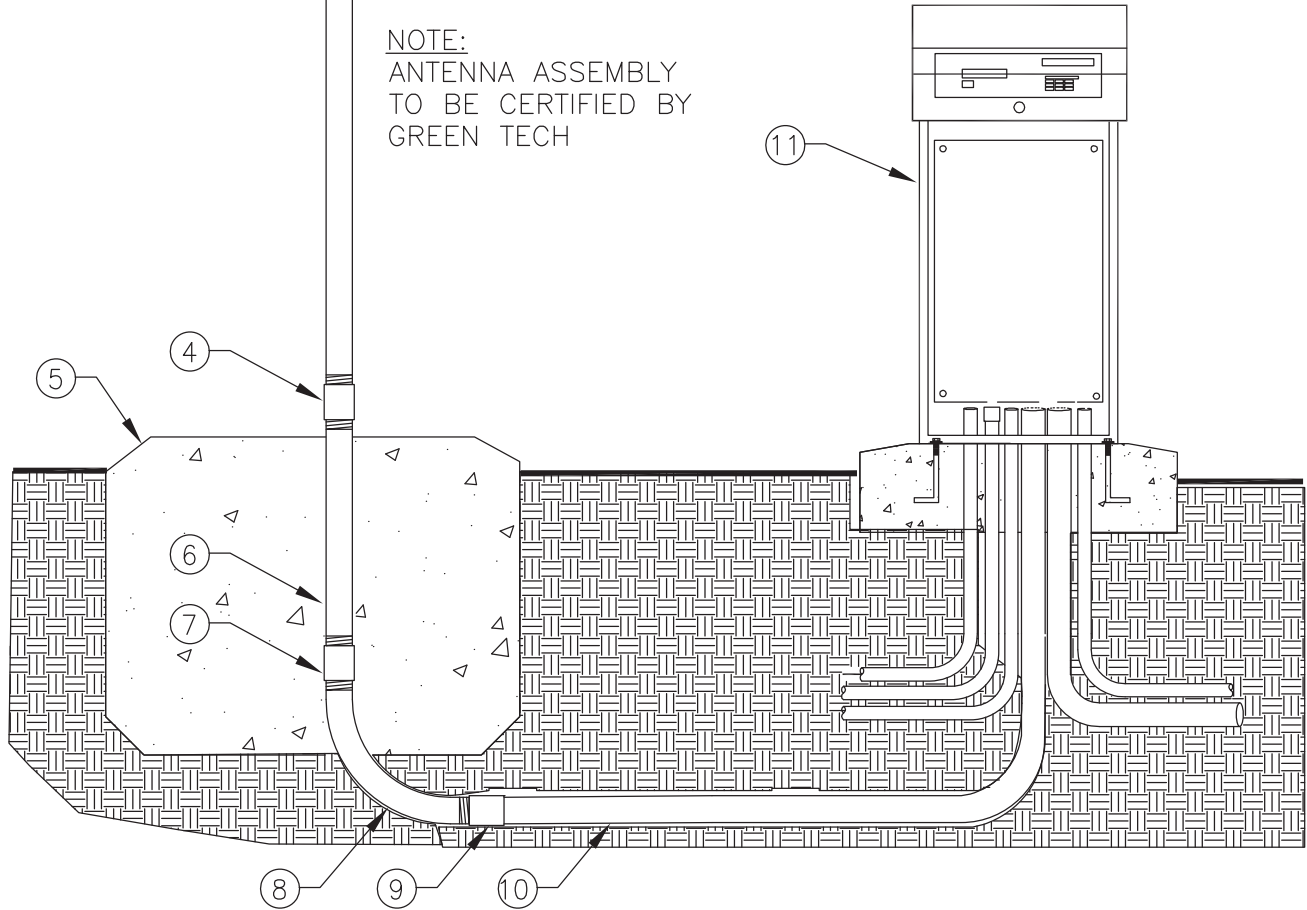

APPROVED  3/8/23
DATE

 CITY OF PITTSBURGH	NO.	DATE	REVISION	DRAWN BY:	CM	STANDARD DETAIL HIGH GAIN ANTENNA	SHEET 1 OF 1 I-5
				CHECKED BY:	MK		
				DATE:	2019-01-11		
				SCALE:	NTS		

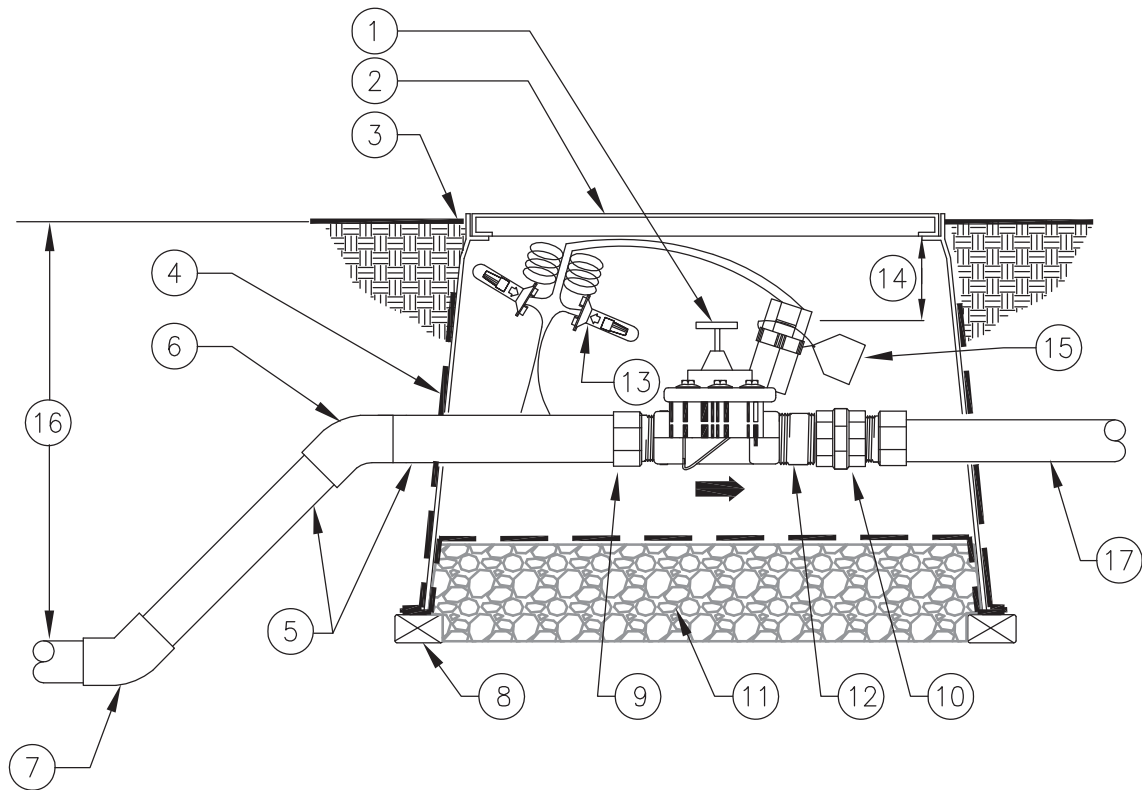

- ① MASTER CONTROL VALVE WITH FLOW CONTROL AND MANUAL BLEED (PRESSURE REGULATOR WHERE SHOWN ON PLANS). CENTER WITHIN BOX
- ② 14" X 19" RECTANGULAR PLASTIC VALVE BOX WITH BOLT DOWN LID. INSTALL BOX AS SHOWN IN BOX INSTALLATION DETAIL
- ③ FINISH GRADE
- ④ 19 GAUGE 1/2" SQUARE WIRE MESH. WRAP UP SIDES OF BOX
- ⑤ SCH. 80 PVC PIPE. LENGTH AS REQUIRED
- ⑥ TYP. PVC SCH. 80 45° ELBOW (SxS)-4 TOTAL
- ⑦ PVC MAIN LINE FROM BACKFLOW OR PUMP
- ⑧ BRICK-ONE ON EACH CORNER
- ⑨ SCH. 80 PVC MALE ADAPTER- 2 TOTAL
- ⑩ SCH. 80 PVC THREADED UNION-2 TOTAL
- ⑪ PEA GRAVEL OR 3/4" DRAIN ROCK- 4" DEEP BELOW VALVE (NO SOIL IN VALVE BOX)
- ⑫ 3" LONG SCH. 80 PVC NIPPLE-2 TOTAL. MATCH VALVE SIZE
- ⑬ VALVE CONTROL WIRE- PROVIDE 3M-DBY SEAL PACKS AT ALL SPLICES AND 36" OF EXCESS UF WIRE IN A 1" DIAMETER COIL
- ⑭ 3" MIN 6" MAX
- ⑮ VALVE I.D. TAG (CONTROLLER AND STATION NUMBER)
- ⑯ REFER TO IRRIGATION LEGEND
- ⑰ PVC MAIN LINE TO FLOW SENSOR

APPROVED

3/8/23

DRAFT

DATE



CITY OF
PITTSBURGH

NO.	DATE	REVISION	DRAWN BY:	CM
			CHECKED BY:	MK
			DATE:	2019-01-11
			SCALE:	NTS

STANDARD DETAIL

MASTER CONTROL VALVE

SHEET 1 OF 1

I-6

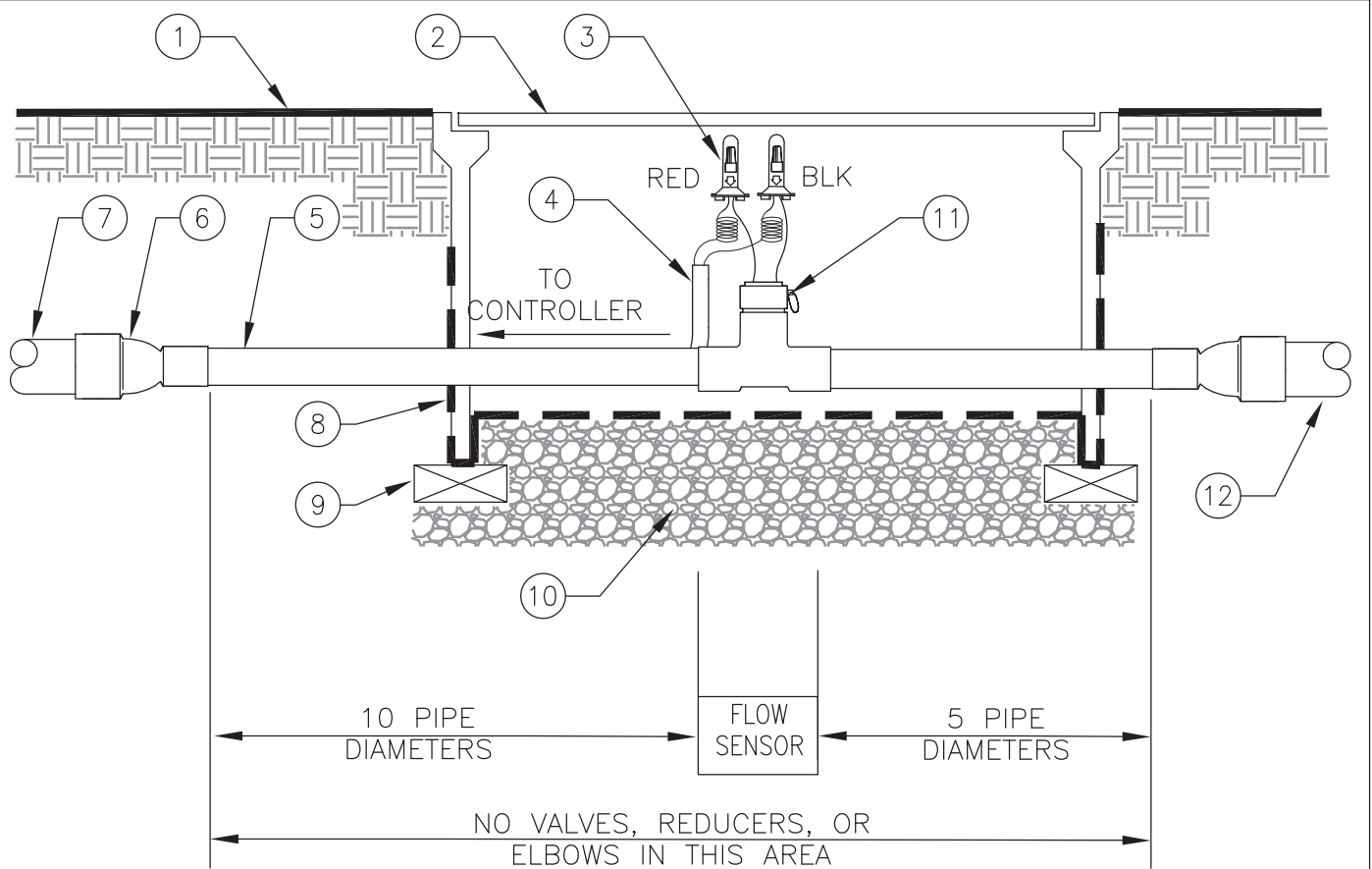

- ① FINISH GRADE
- ② 14" X 19" RECTANGULAR PLASTIC VALVE BOX WITH BOLT DOWN LID. INSTALL BOX AS SHOWN IN BOX INSTALLATION DETAIL
- ③ 18 GAUGE AWG DIRECT BURIAL WIRE. FLOW SENSOR WIRE MUST BE RUN IN 1" PVC CONDUIT FROM FLOW SENSOR TO CONTROLLER ENCLOSURE. PROVIDE 3M-DBY SEAL PACKS AT ALL SPLICES AND 36" OF EXCESS WIRE IN A 1" DIAMETER COIL
- ④ 1" SCH 40 PVC CONDUIT
- ⑤ SCH. 80 PVC PIPE
- ⑥ SCH. 80 PVC REDUCER IF REQUIRED
- ⑦ PVC MAIN LINE TO MASTER CONTROL VALVE
- ⑧ 19 GAUGE 1/2" SQUARE WIRE MESH. WRAP UP SIDES OF BOX
- ⑨ BRICK-ONE ON EACH CORNER
- ⑩ PEA GRAVEL OR 3/4" DRAIN ROCK- 4" DEEP BELOW VALVE (NO SOIL IN VALVE BOX)
- ⑪ FLOW SENSOR MUST BE INSTALLED WITH INSERT (TOP) POSITIONED VERTICALLY AND BODY (TEE) POSITIONED HORIZONTALLY
- ⑫ PVC MAIN LINE TO IRRIGATION SYSTEM

APPROVED

3/8/23

DRAFT

DATE

 CITY OF PITTSBURGH	NO.	DATE	REVISION	DRAWN BY: CM	STANDARD DETAIL FLOW SENSOR	SHEET 1 OF 1 I-7
				CHECKED BY: MK		
				DATE: 2019-01-11		
				SCALE: NTS		

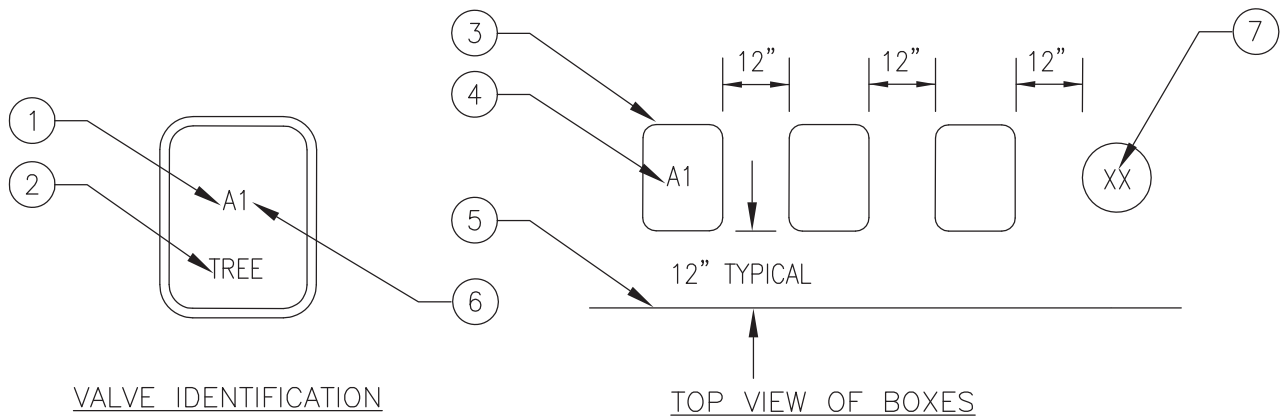

- ① CONTROLLER ID
- ② ALL TREE VALVES TO HAVE TREE BRANDED INTO LID
- ③ RECTANGULAR VALVE BOX
- ④ HEAT BRAND VALVE TYPE PER TABLE OR CONTROLLER ID AND STATION NUMBER INTO LID
- ⑤ EDGE OF LAWN, WALK, FENCE, CURB, ETC
- ⑥ STATION NUMBER
- ⑦ ROUND VALVE BOX FOR QCV AND GATE VALVE. HEAT BRAND VALVE TYPE INTO INTO LID PER TABLE

ITEMS TO BRAND:	BRAND CODE
GATE VALVE	GV
PRESSURE REDUCER	PRV
MASTER VALVE	MV
FLOW SENSOR	FS
HYDROMETER	HM
MAIN LINE AIR RELIEF	ARV
REMOTE CONTROL VALVE	A1 → A48
QUICK COUPLER	QC
SPLICE BOX	SB
PULL BOX	PB
LIGHTNING ARRESTOR	LA
GROUND ROD	GR

INSTRUCTIONS:

1. CENTER VALVE BOX OVER REMOTE CONTROL VALVE TO FACILITATE SERVICING VALVE
2. SET BOXES 1" ABOVE FINISH GRADE OR MULCH COVER IN GROUND COVER/SHRUB AREA AND FLUSH WITH FINISH GRADE IN TURF AREA
3. SET RCV AND VALVE BOX ASSEMBLY IN GROUND COVER/SHRUB AREA WHERE POSSIBLE. INSTALL IN LAWN ONLY IF GROUND COVER DOES NOT EXIST ADJACENT TO LAWN
4. SET BOXES PARALLEL TO EACH OTHER AND PERPENDICULAR TO EDGE OF LAWN, WALK, FENCE, CURB, ETC
5. AVOID HEAVILY COMPACTING SOIL AROUND VALVE BOXES TO PREVENT COLLAPSE AND DEFORMATION OF VALVE BOX SIDES
6. INSTALL EXTENSION BY VALVE BOX MANUFACTURER AS REQUIRED TO COMPLETELY ENCLOSE ASSEMBLY FOR EASY ACCESS

APPROVED

3/8/23

DRAFT

DATE

	NO.	DATE	REVISION	DRAWN BY: CM	<p align="center">STANDARD DETAIL</p> <p align="center">IRRIGATION VALVE BOX INSTALLATION</p>	<p align="center">SHEET 1 OF 1</p> <p align="center">1-8</p>
				CHECKED BY: MK		
				DATE: 2019-01-11		
				SCALE: NTS		

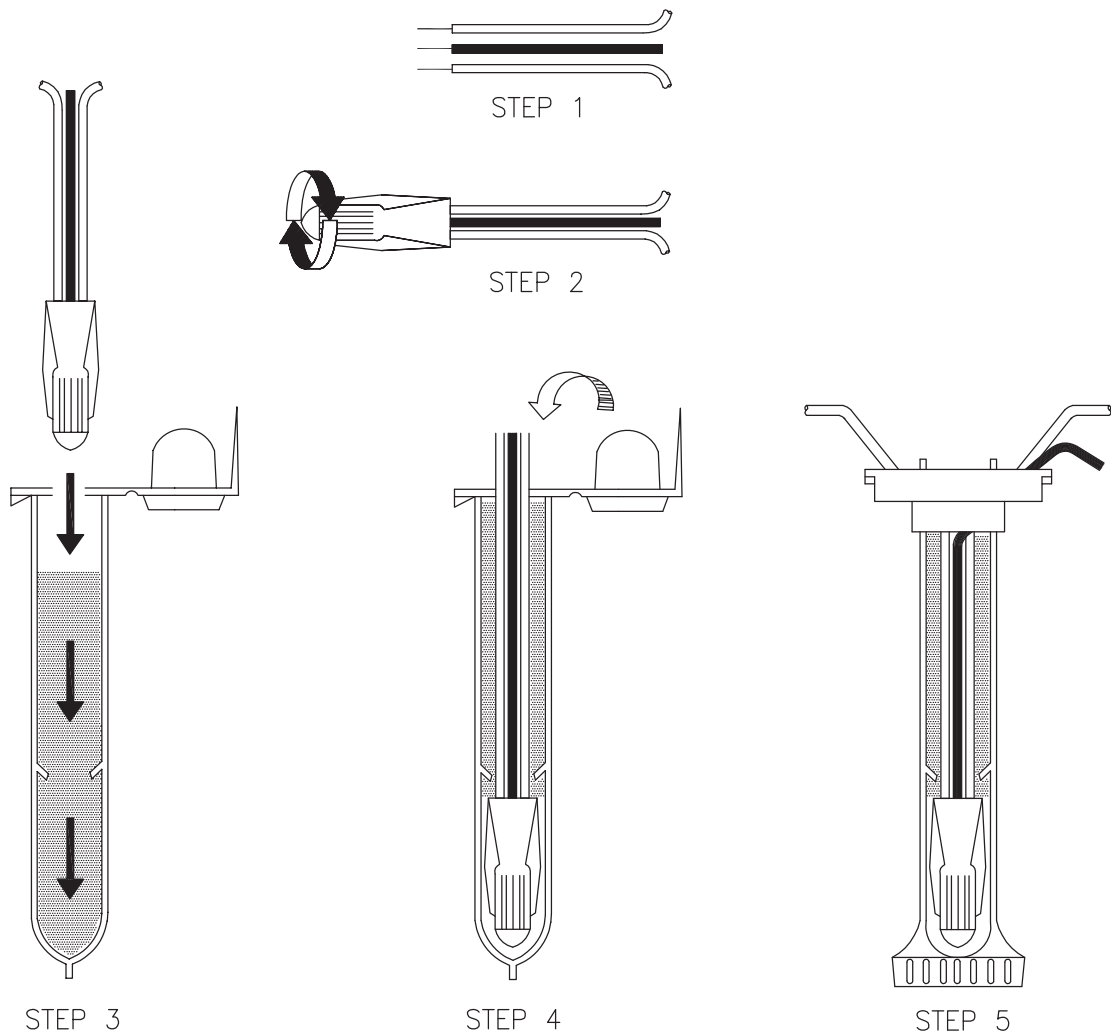

NOTE:

MAXIMUM # OF WIRES PER CONNECTOR:

- 3-#14 GAUGE
- 2-#12 GAUGE

INSTRUCTIONS:

1. STRIP WIRES APPROXIMATELY 1/2" FROM ENDS TO EXPOSE WIRE
2. TWIST CONNECTOR AROUND WIRES CLOCKWISE UNTIL HAND TIGHT, DO NOT OVERTIGHTEN
3. INSERT WIRE ASSEMBLY TO BOTTOM OF GEL-FILLED TUBE. CHECK TO MAKE SURE CONNECTOR HAS BEEN PUSHED PAST LOCKING FINGERS AND IS SEATED AT THE BOTTOM OF THE TUBE
4. PLACE WIRES WHICH EXIT TUBE IN WIRE EXIT HOLES AND CLOSE CAP UNTIL IT SNAPS
5. INSPECT FINAL SPLICE ASSEMBLY THAT IT IS SECURED

APPROVED  DATE 3/8/23

DRAFT

 CITY OF PITTSBURGH	NO.	DATE	REVISION	DRAWN BY: CM	<u>STANDARD DETAIL</u> WEATHERPROOF WIRE SPLICE ASSEMBLY	SHEET 1 OF 1
				CHECKED BY: MK		1-9
				DATE: 2019-01-11		
				SCALE: NTS		

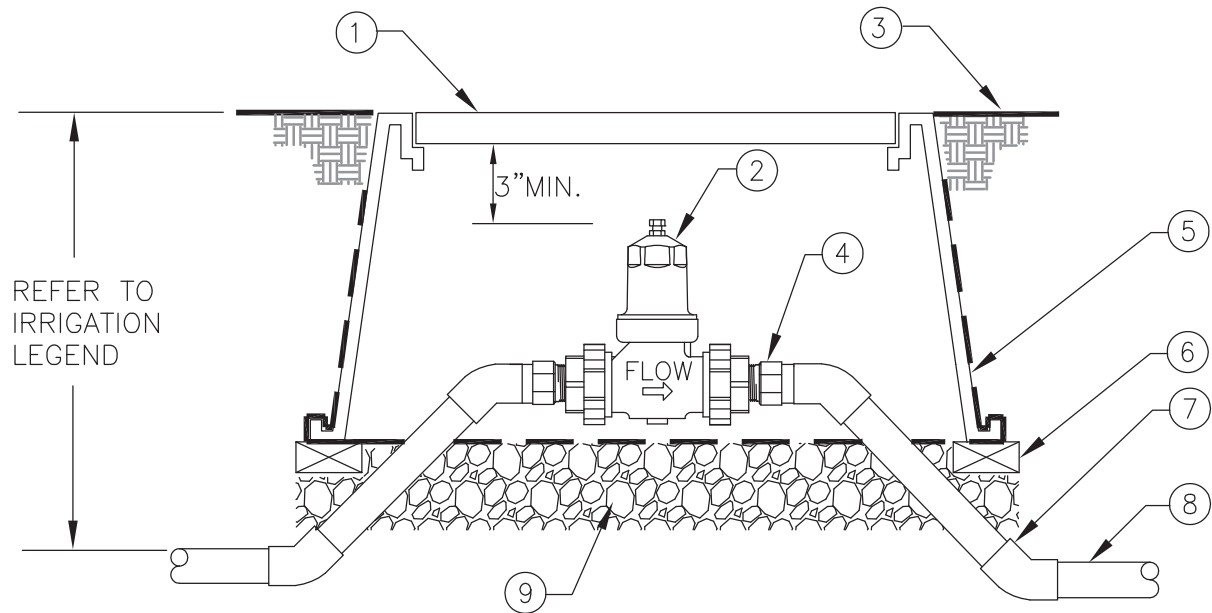

- ① RECTANGULAR PLASTIC VALVE BOX WITH BOLT- DOWN LID. INSTALL BOX AS SHOWN IN BOX INSTALLATION DETAIL. TOP DIMENSION: 15 3/4" X 25 1/4" (15" DEEP)
- ② PRESSURE REDUCING VALVE: WILKINS 600XL OR APPROVED EQUAL
- ③ FINISH GRADE
- ④ SCHEDULE 80 PVC MALE ADAPTER. (2 TOTAL)
- ⑤ 19 GAUGE 1/2" SQUARE WIRE MESH. WRAP UP SIDES OF BOX
- ⑥ BRICK - ONE EACH CORNER OF BOX
- ⑦ TYP. PVC SCHEDULE 80 45° ELBOW (SxS)
- ⑧ PVC MAIN LINE
- ⑨ PEA GRAVEL - 4" DEEP (NO SOIL IN VALVE BOX)

APPROVED

3/8/23

DRAFT

DATE



CITY OF
PITTSBURGH

NO.	DATE	REVISION	DRAWN BY:	CM
			CHECKED BY:	MK
			DATE:	2019-01-11
			SCALE:	NTS

STANDARD DETAIL

PRESSURE REDUCING VALVE

SHEET 1 OF 1

I-10

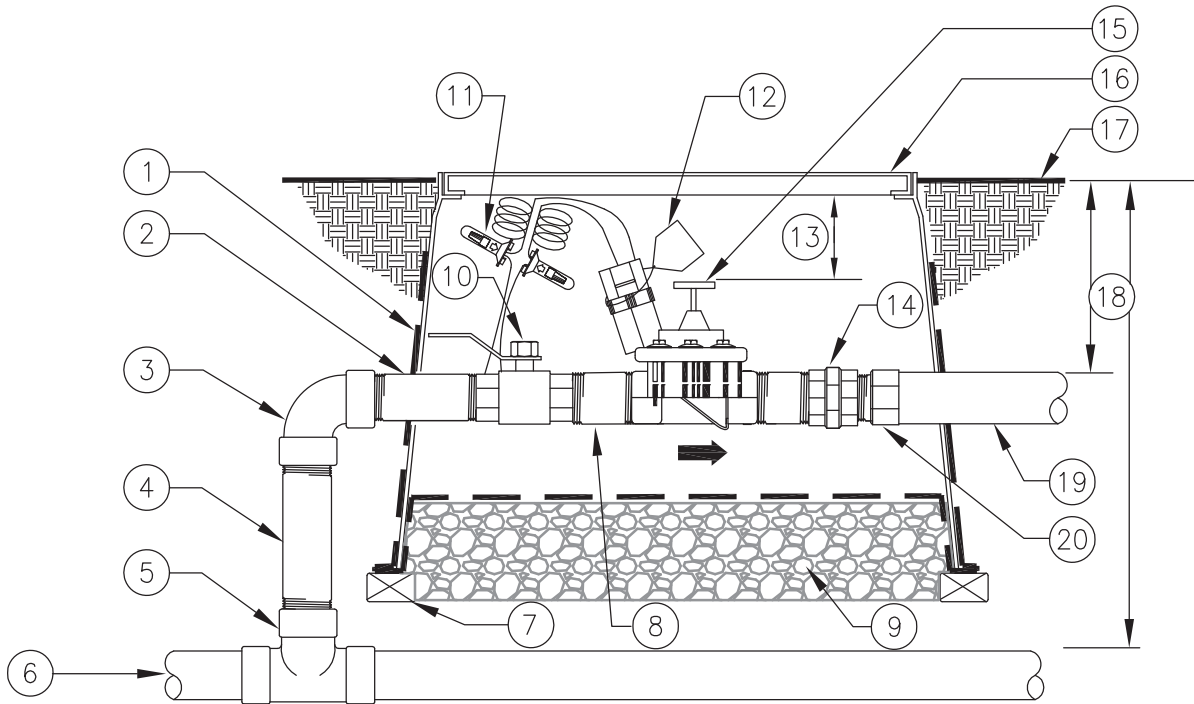

- ① 19 GAUGE 1/2" SQUARE WIRE MESH. WRAP UP SIDES OF BOX
- ② SCH. 80 PVC NIPPLE (8"-12" IN LENGTH). LENGTH AS REQUIRED TO PROVIDE CLEARANCE FOR BALL VALVE HANDLE. MATCH VALVE SIZE
- ③ SCH. 80 PVC 90° ELBOW (T×T)
- ④ SCH. 80 PVC NIPPLE. LENGTH AS REQUIRED
- ⑤ SCH. 40 OR 80 PVC TEE. REFER TO LEGEND FOR TYPE
- ⑥ PVC MAIN LINE
- ⑦ BRICK-ONE ON EACH CORNER
- ⑧ 3" LONG SCH. 80 PVC NIPPLE. MATCH VALVE SIZE (2 TOTAL)
- ⑨ PEA GRAVEL OR 3/4" DRAIN ROCK. 4" DEEP BELOW VALVE (NO SOIL IN VALVE BOX)
- ⑩ BRASS BALL VALVE-1 PER VALVE. PROVIDE ENOUGH CLEARANCE FROM EDGE OF BOX FOR VALVE TO OPERATE
- ⑪ VALVE CONTROL WIRE. PROVIDE 3M-DBY SEAL PACKS AT ALL SPLICES AND 36" OF EXCESS UF WIRE IN A 1" DIA. COIL
- ⑫ VALVE I.D. TAG (CONTROLLER AND STATION NUMBER)
- ⑬ 3" MIN 6" MAX
- ⑭ SCH. 80 PVC THREADED UNION
- ⑮ REMOTE CONTROL VALVE WITH FLOW CONTROL AND MANUAL BLEED (PRESSURE REGULATOR WHERE SHOWN ON PLANS)
- ⑯ 14" X 19" RECTANGULAR PLASTIC VALVE BOX WITH BOLT DOWN LID. ONE VALVE PER BOX- NO EXCEPTIONS. INSTALL BOX AS SHOWN IN BOX INSTALLATION DETAIL
- ⑰ FINISH GRADE
- ⑱ REFER TO IRRIGATION LEGEND
- ⑲ PVC LATERAL LINE
- ⑳ SCH. 80 PVC MALE ADAPTER

APPROVED

3/8/23

DRAFT

DATE



CITY OF
PITTSBURGH

NO.	DATE	REVISION	DRAWN BY:	CM
			CHECKED BY:	MK
			DATE:	2019-01-11
			SCALE:	NTS

STANDARD DETAIL

REMOTE CONTROL VALVE

SHEET 1 OF 3

I-11

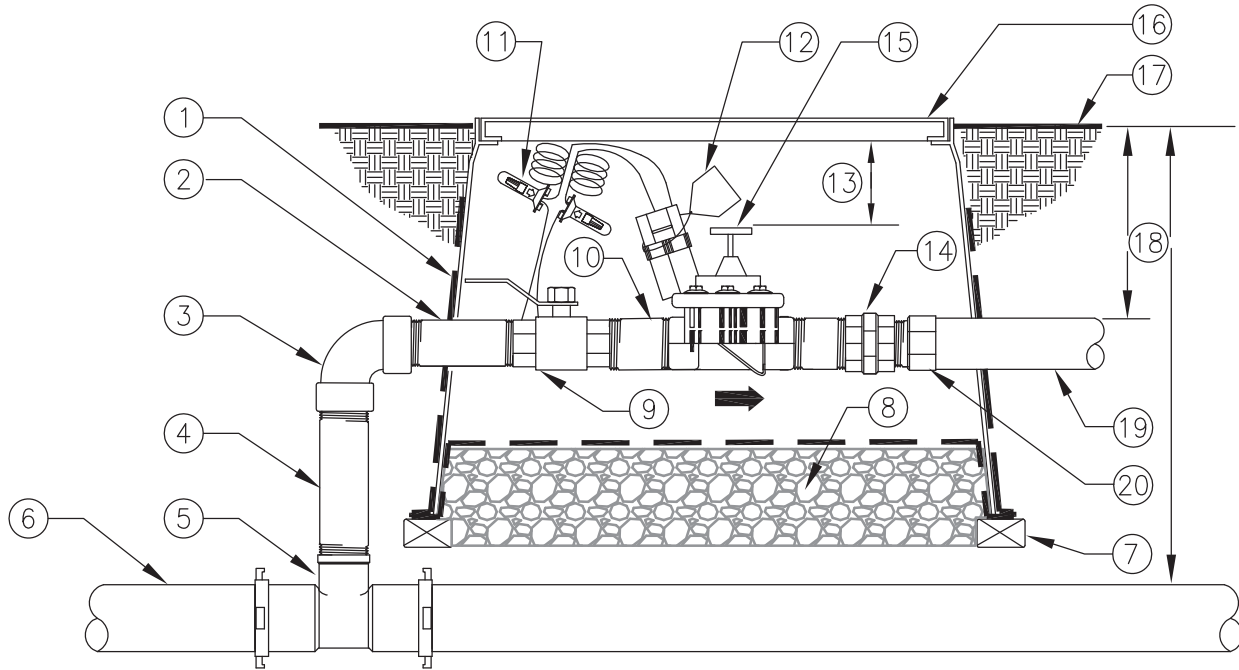

- ① 19 GAUGE 1/2" SQUARE WIRE MESH. WRAP UP SIDES OF BOX
- ② SCH. 80 PVC NIPPLE (8"-12" IN LENGTH). LENGTH AS REQUIRED TO PROVIDE CLEARANCE FOR BALL VALVE HANDLE. MATCH VALVE SIZE
- ③ SCH. 80 PVC 90° ELBOW (T×T)
- ④ SCH. 80 PVC NIPPLE. LENGTH AS REQUIRED
- ⑤ GASKETED DUCTILE IRON SERVICE TEE
- ⑥ CLASS 200 RING TITE PVC MAIN LINE
- ⑦ BRICK—ONE ON EACH CORNER
- ⑧ PEA GRAVEL OR 3/4" DRAIN ROCK. 4" DEEP BELOW VALVE (NO SOIL IN VALVE BOX)
- ⑨ BRASS BALL VALVE—1 PER VALVE. PROVIDE ENOUGH CLEARANCE FROM EDGE OF BOX FOR VALVE TO OPERATE
- ⑩ 3" LONG SCH. 80 PVC NIPPLE. MATCH VALVE SIZE (2 TOTAL)
- ⑪ VALVE CONTROL WIRE. PROVIDE 3M—DBY SEAL PACKS AT ALL SPLICES AND 36" OF EXCESS UF WIRE IN A 1" DIA. COIL
- ⑫ VALVE I.D. TAG (CONTROLLER AND STATION NUMBER)
- ⑬ 3" MIN 6" MAX
- ⑭ SCH. 80 PVC THREADED UNION
- ⑮ REMOTE CONTROL VALVE WITH FLOW CONTROL AND MANUAL BLEED (PRESSURE REGULATOR WHERE SHOWN ON PLANS)
- ⑯ 14" X 19" RECTANGULAR PLASTIC VALVE BOX WITH BOLT DOWN LID. ONE VALVE PER BOX— NO EXCEPTIONS. INSTALL BOX AS SHOWN IN BOX INSTALLATION DETAIL.
- ⑰ FINISH GRADE
- ⑱ REFER TO IRRIGATION LEGEND
- ⑲ PVC LATERAL LINE
- ⑳ SCH. 80 PVC MALE ADAPTER

APPROVED

3/8/23

DRAFT

DATE



CITY OF
PITTSBURG

NO.	DATE	REVISION	DRAWN BY:	CM
			CHECKED BY:	MK
			DATE:	2019-01-11
			SCALE:	NTS

STANDARD DETAIL

REMOTE CONTROL VALVE —
GASKETED MAIN

SHEET 2 OF 3

I-11

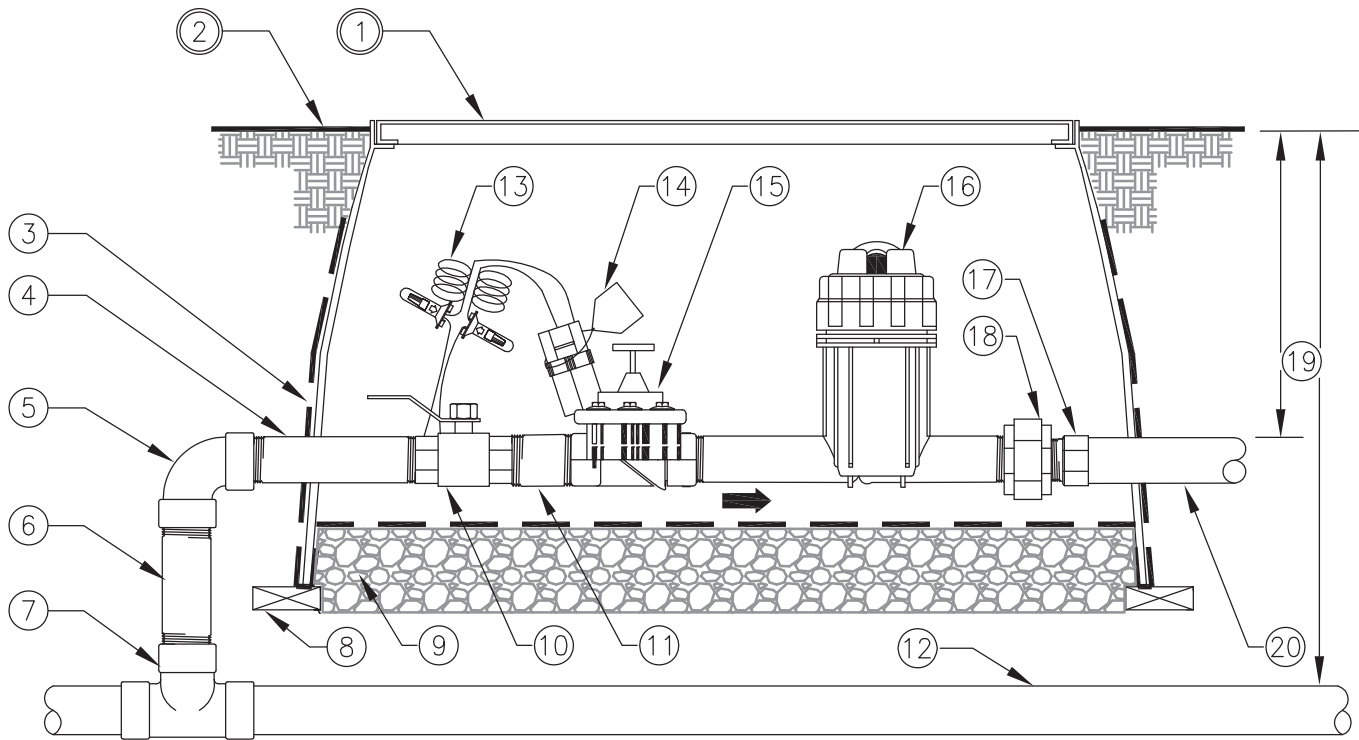

- ① RECTANGULAR PLASTIC VALVE BOX WITH BOLT DOWN LID. ONE VALVE PER BOX—NO EXCEPTIONS. INSTALL BOX AS SHOWN IN BOX INSTALLATION DETAIL
- ② FINISH GRADE
- ③ 19 GAUGE 1/2" SQUARE WIRE MESH. WRAP UP SIDES OF BOX
- ④ SCH. 80 PVC NIPPLE (8"—12" IN LENGTH). LENGTH AS REQUIRED TO PROVIDE CLEARANCE FOR BALL VALVE HANDLE. MATCH VALVE SIZE
- ⑤ SCH. 80 PVC 90° ELBOW (T×T)
- ⑥ SCH. 80 PVC NIPPLE. LENGTH AS REQUIRED
- ⑦ SCH. 40 OR 80 PVC TEE. REFER TO LEGEND FOR TYPE
- ⑧ BRICK—ONE ON EACH CORNER
- ⑨ PEA GRAVEL OR 3/4" DRAIN ROCK. 4" DEEP BELOW VALVE (NO SOIL IN VALVE BOX)
- ⑩ BRASS BALL VALVE—1 PER VALVE. PROVIDE ENOUGH CLEARANCE FROM EDGE OF BOX FOR VALVE TO OPERATE
- ⑪ 3" LONG SCH. 80 PVC NIPPLE. MATCH VALVE SIZE (2 TOTAL)
- ⑫ PVC MAIN LINE
- ⑬ VALVE CONTROL WIRE. PROVIDE 3M—DBY SEAL PACKS AT ALL SPLICES AND 36" OF EXCESS UF WIRE IN A 1" DIA. COIL
- ⑭ VALVE I.D. TAG (CONTROLLER AND STATION NUMBER)
- ⑮ REMOTE CONTROL VALVE
- ⑯ PRESSURE REDUCING FILTER (40 PSI)
- ⑰ SCH. 80 PVC MALE ADAPTER
- ⑱ SCH. 80 PVC THREADED UNION
- ⑲ REFER TO IRRIGATION LEGEND
- ⑳ PVC LATERAL LINE

APPROVED

3/8/23

DRAFT

DATE

 CITY OF PITTSBURGH	NO.	DATE	REVISION	DRAWN BY:	CM	STANDARD DETAIL REMOTE CONTROL VALVE — DRIP	SHEET 3 OF 3 I-11
				CHECKED BY:	MK		
				DATE:	2019-01-11		
				SCALE:	NTS		

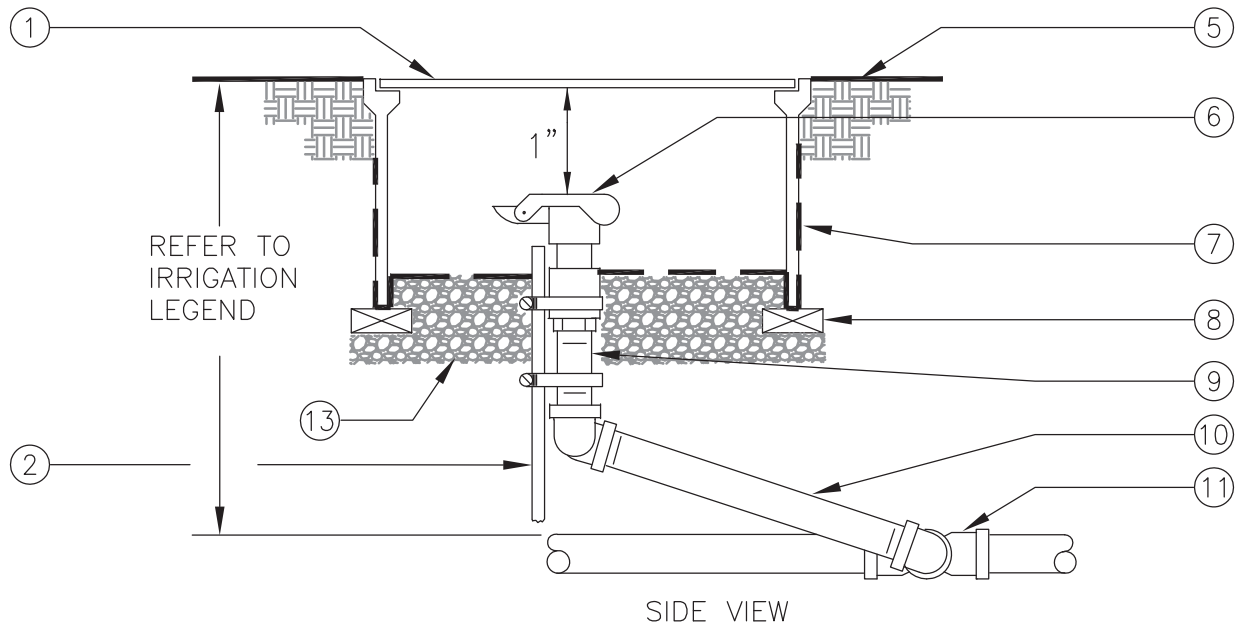

SIDE VIEW

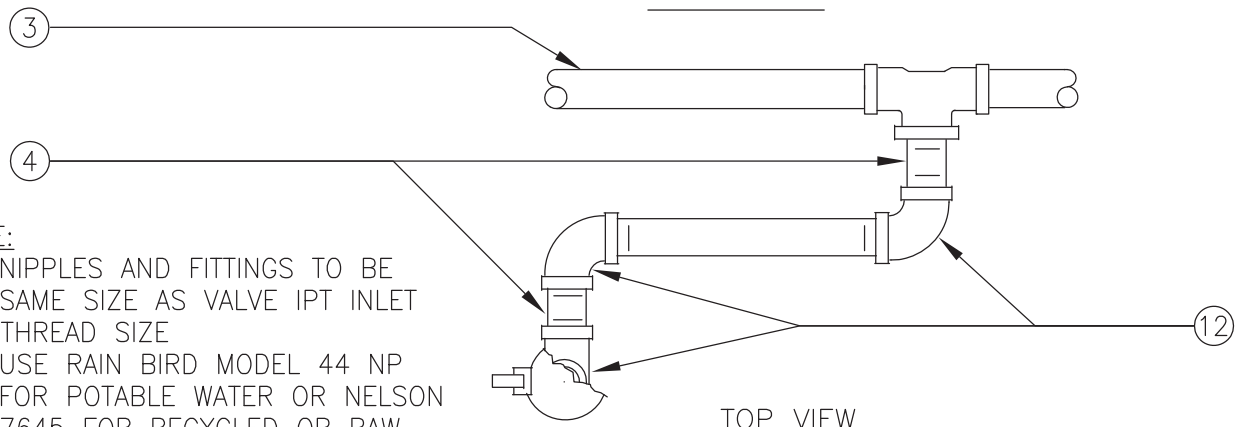

TOP VIEW

NOTE:

1. NIPPLES AND FITTINGS TO BE SAME SIZE AS VALVE IPT INLET THREAD SIZE
2. USE RAIN BIRD MODEL 44 NP FOR POTABLE WATER OR NELSON 7645 FOR RECYCLED OR RAW WATER

- | | |
|---|--|
| <ul style="list-style-type: none"> ① 10" ROUND PLASTIC VALVE BOX WITH BOLT DOWN LID ② 1 1/4" x 1 1/4" x 3/16" ANGLE IRON 30" LONG W/2 STAINLESS STEEL STRAPS (ONE AROUND QCV) ③ PVC MAIN LINE ④ 3" LONG SCHEDULE 80 PVC THREADED NIPPLE ⑤ FINISH GRADE ⑥ QUICK COUPLING VALVE ⑦ 19 GAUGE 1/2" SQUARE WIRE MESH. WRAP UP SIDES OF BOX | <ul style="list-style-type: none"> ⑧ BRICK - 2 TOTAL ⑨ SCHEDULE 80 PVC THREADED NIPPLE ⑩ 10" LONG SCHEDULE 80 PVC THREADED NIPPLE ⑪ UPC APPROVED SCHEDULE 40 PVC TEE OR ELBOW ⑫ SCHEDULE 80 PVC THREADED 90° ELL ⑬ PEA GRAVEL OR 3/4" DRAIN ROCK- 4" DEEP BELOW VALVE (NO SOIL IN VALVE BOX) |
|---|--|

APPROVED

3/8/23

DRAFT

DATE

	NO.	DATE	REVISION	DRAWN BY: CM	<u>STANDARD DETAIL</u> QUICK COUPLING VALVE	SHEET 1 OF 1 I-12
				CHECKED BY: MK		
				DATE: 2019-01-11		
				SCALE: NTS		

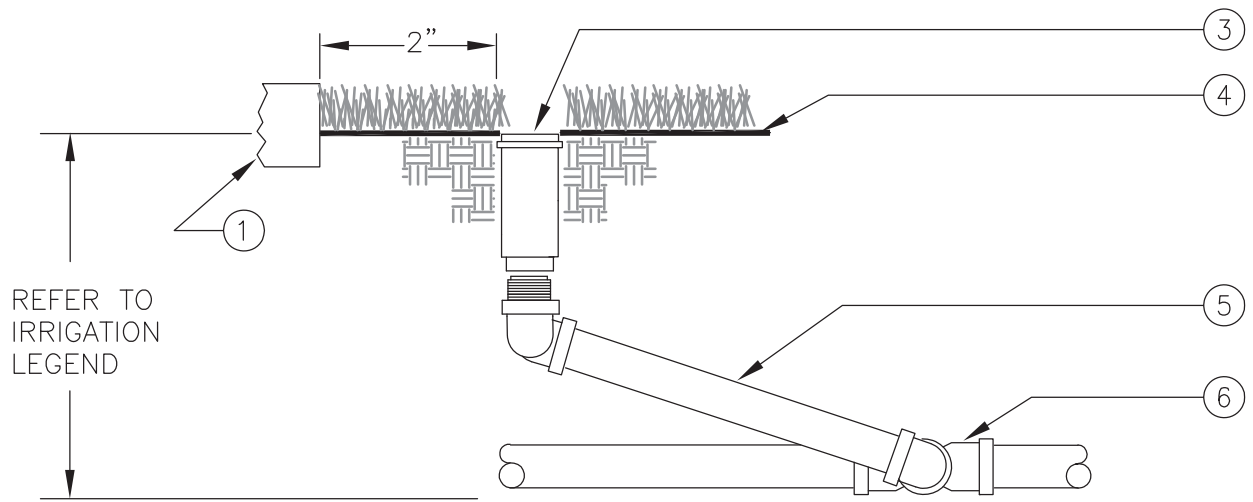

SIDE VIEW

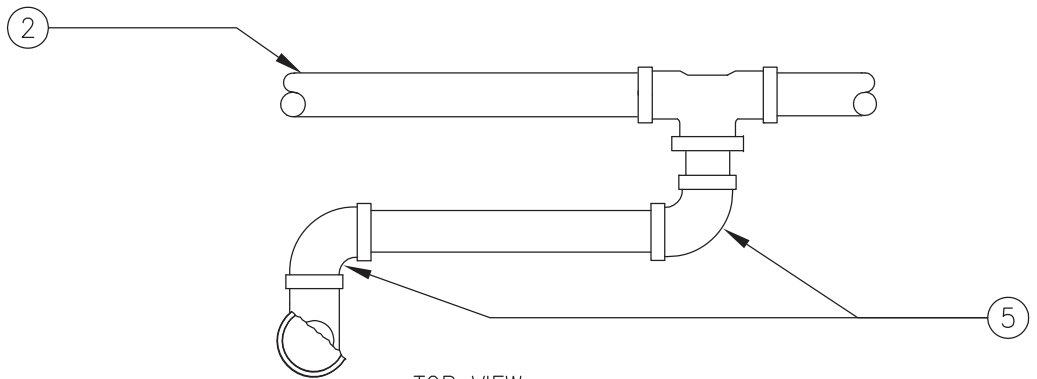

TOP VIEW

NOTES:

1. SET SPRINKLER 1" ABOVE FINISH GRADE AT TIME OF INSTALLATION – LOWER TO FINISH GRADE WHEN TURF IS WELL ESTABLISHED

- ① WALL, WALK, CURB OR HEADER
- ② PVC LATERAL LINE
- ③ POP-UP ROTARY SPRINKLER
- ④ FINISH GRADE

- ⑤ UNITIZED SWING JOINT: 3/4"–LASCO MODEL T732–212
1"–LASCO MODEL T932–212
- ⑥ SCHEDULE 40 PVC TEE OR ELBOW WITH THREADED OUTLET

APPROVED

3/8/23

DATE

DRAFT



CITY OF PITTSBURGH

NO.	DATE	REVISION	DRAWN BY:	CM
			CHECKED BY:	MK
			DATE:	2019-01-11
			SCALE:	NTS

STANDARD DETAIL

POP-UP ROTOR – TURF AREAS

SHEET 1 OF 3

I-13

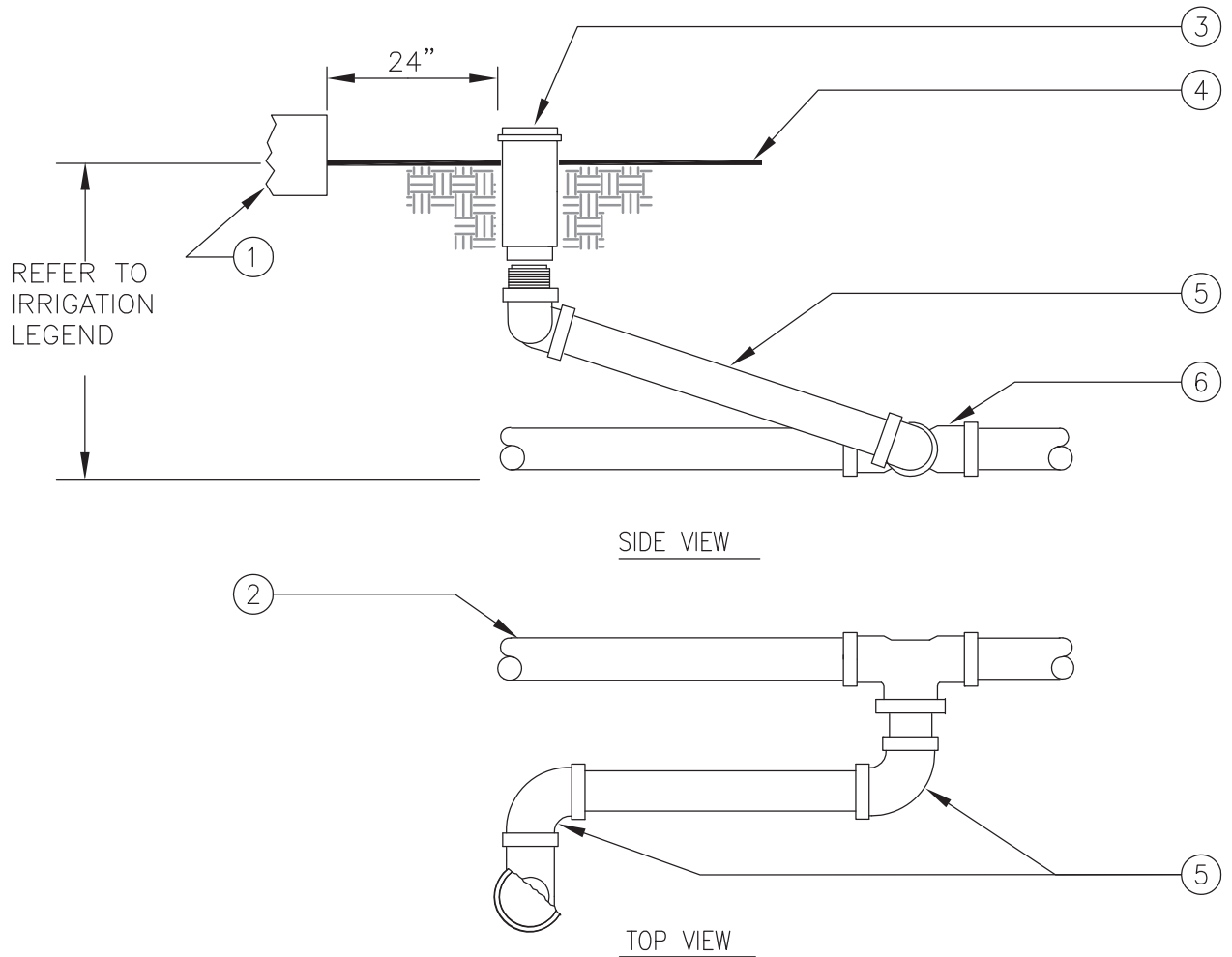

NOTES:

1. SET SPRINKLER 2" ABOVE FINISH GRADE

① WALL, WALK, CURB OR HEADER

② PVC LATERAL LINE

③ POP-UP ROTARY SPRINKLER

④ FINISH GRADE

⑤ UNITIZED SWING JOINT: 3/4"–LASCO MODEL T732–212

1"–LASCO MODEL T932–212

⑥ SCHEDULE 40 PVC TEE OR ELBOW WITH THREADED OUTLET

APPROVED

3/8/23

DRAFT

DATE



CITY OF PITTSBURGH

NO.	DATE	REVISION	DRAWN BY:	CM
			CHECKED BY:	MK
			DATE:	2019-01-11
			SCALE:	NTS

STANDARD DETAIL

POP-UP ROTOR – GROUND COVER/SHRUB AREAS

SHEET 2 OF 3

I-13

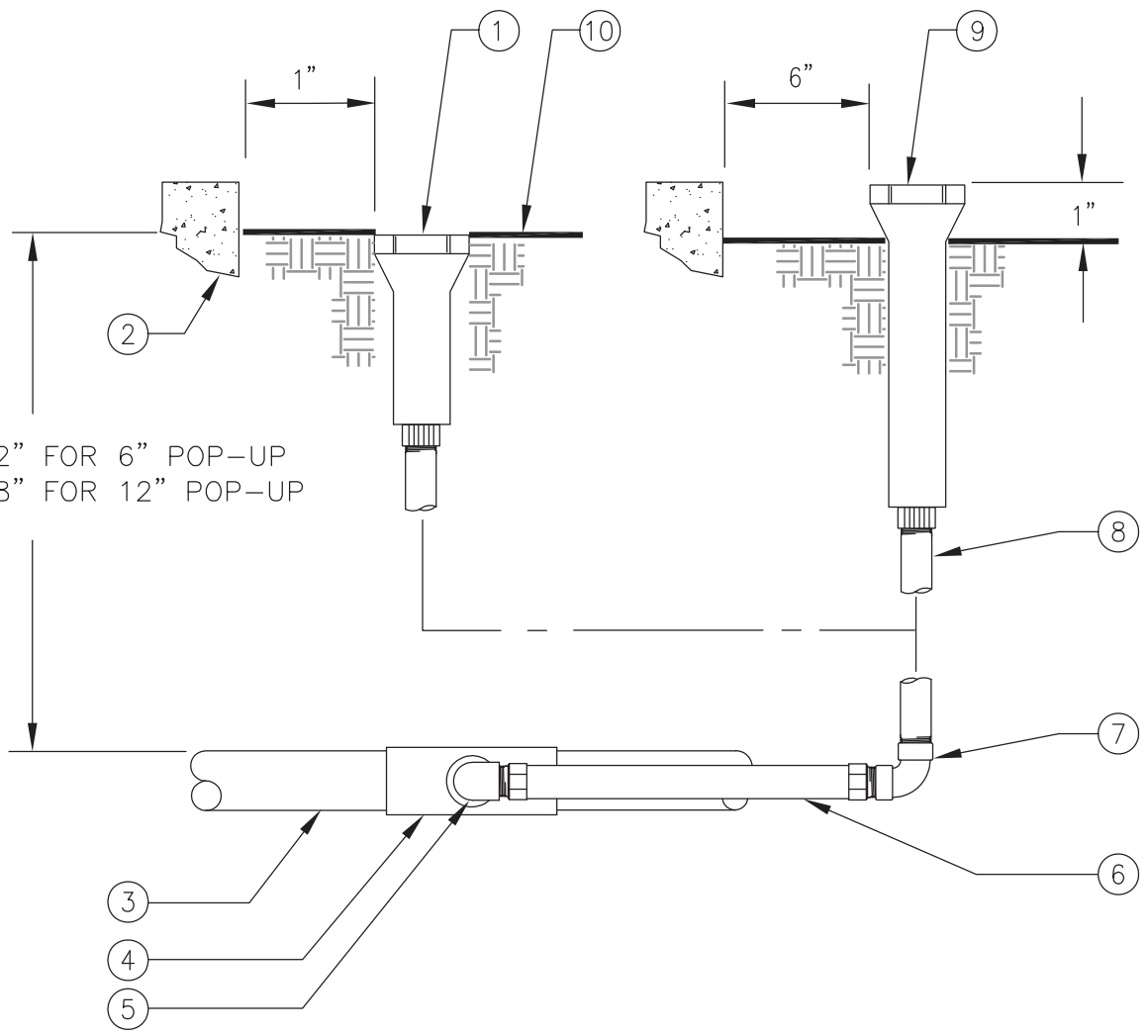

- 12" FOR 6" POP-UP
- 18" FOR 12" POP-UP

- ① POP-UP LAWN
- ② WALL, WALK, CURB OR BUILDING
- ③ PVC LATERAL LINE
- ④ SCH. 40 PVC TEE OR ELBOW
- ⑤ 1/2" SCH. 40 PVC STREET ELL
- ⑥ 1/2" FLEXIBLE IPS HOSE 6" LONG WITH MALE ADAPTERS
- ⑦ 1/2" SCH. 40 PVC THREADED 90° ELL
- ⑧ 1/2" SCH. 80 PVC THREADED NIPPLE (LENGTH AS REQUIRED)
- ⑨ POP-UP SHRUB SPRAY SPRINKLER OR BUBBLER
- ⑩ FINISH GRADE

APPROVED

3/8/23

DATE

DRAFT



CITY OF
PITTSBURGH

NO.	DATE	REVISION	DRAWN BY:	CM
			CHECKED BY:	MK
			DATE:	2019-01-11
			SCALE:	NTS

STANDARD DETAIL

POP-UP SPRAY SPRINKLER

SHEET 3 OF 3

I-13

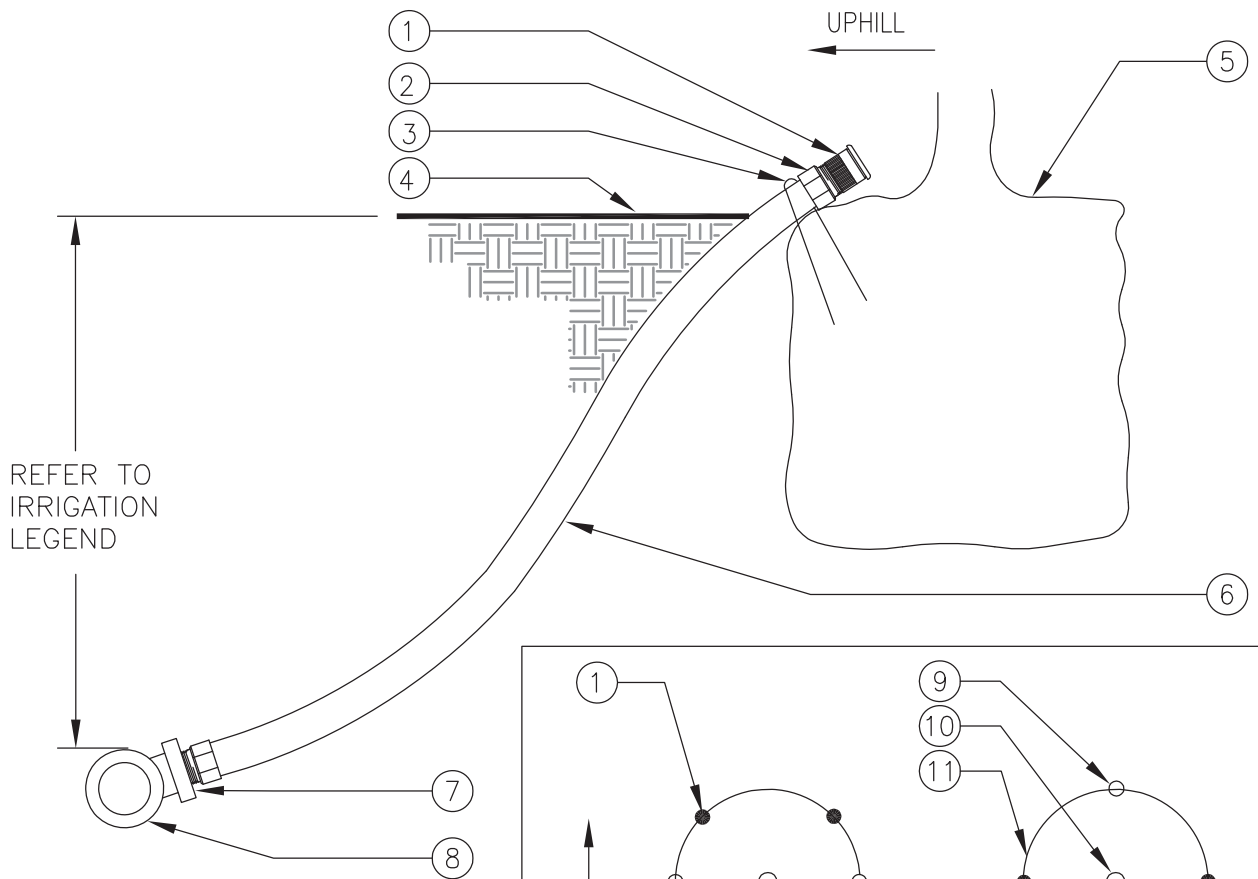

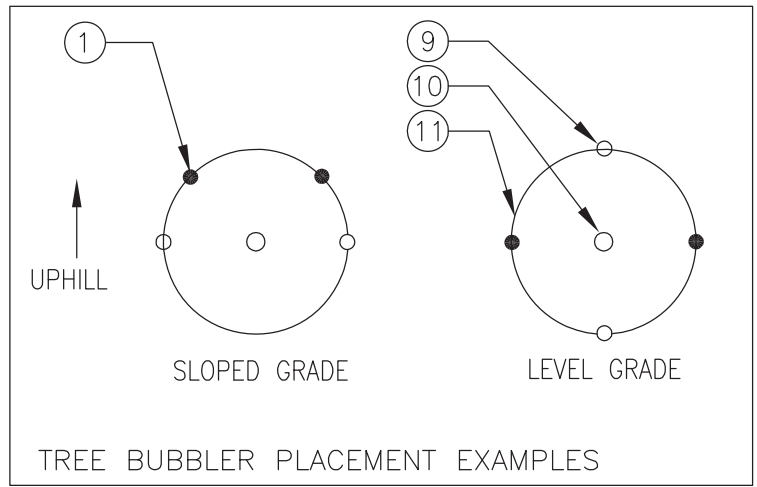

NOTE:
 SUGGESTED QUANTITY OF BUBBLERS
 PER TREES AND SHRUBS SIZE:

- SHRUBS = 1 BUBBLER
- 15 GAL OR 24" BOX = 2 BUBBLERS
- 36" OR 48" BOX = 4 BUBBLERS



- ① BUBBLER (TO BE INSTALLED ON TOP OF ROOTBALL)
- ② 1/2" SCH. 40 MALE ADAPTER
- ③ 6" STAPLE
- ④ FINISH GRADE
- ⑤ TREE OR SHRUB ROOTBALL
- ⑥ 1/2" IPS FLEXIBLE PVC
- ⑦ PVC TEE (SST), ELBOW (ST) OR FEMALE ADAPTER
- ⑧ PVC LATERAL LINE
- ⑨ TREE STAKES
- ⑩ TREE OR SHRUB
- ⑪ EDGE OF ROOTBALL (TYPICAL)

APPROVED  DATE 3/8/23

 CITY OF PITTSBURGH	NO.	DATE	REVISION	DRAWN BY: CM	STANDARD DETAIL TREE & SHRUB BUBBLER - NON-TURF AREAS	SHEET 1 OF 2 I-14
				CHECKED BY: MK		
				DATE: 2019-01-11		
				SCALE: NTS		

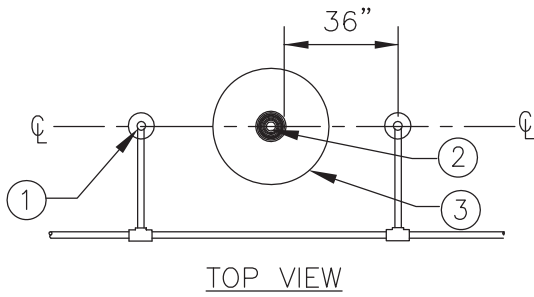

NOTE:
INSTALL 2 POP-UP
BUBBLERS PER TREE.

- ① 6" POP-UP SPRAY BUBBLER WITH 5 FT MPR NOZZLE. ADJUST NOZZLE RADIUS TO PREVENT DIRECT SPRAY ONTO TRUNK. INSTALL POP-UP SPRINKLER PER CITY STD DETAIL I-13
- ② BASE OF TREE
- ③ ROOT BALL
- ④ SPRINKLER RISER. INSTALL POP-UP SPRINKLER PER CITY STD DETAIL I-13
- ⑤ SCH. 40 PVC TEE OR ELBOW
- ⑥ LATERAL LINE

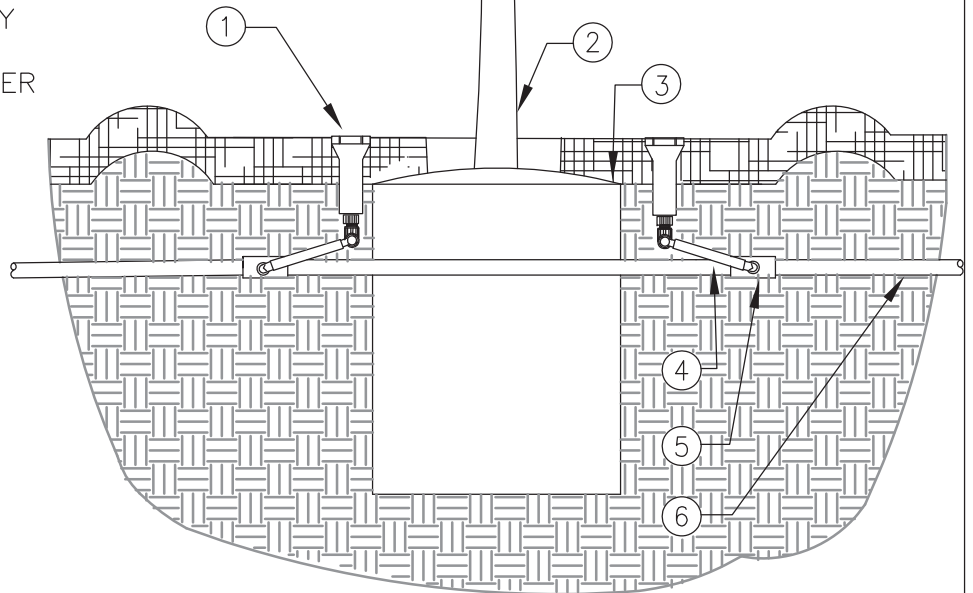

APPROVED _____

3/8/23

DRAFT

DATE



CITY OF
PITTSBURGH

NO.	DATE	REVISION

DRAWN BY:	CM
CHECKED BY:	MK
DATE:	2019-01-11
SCALE:	NTS

STANDARD DETAIL

POP-UP TREE BUBBLER - TURF
AREAS

SHEET 2 OF 2

I-14

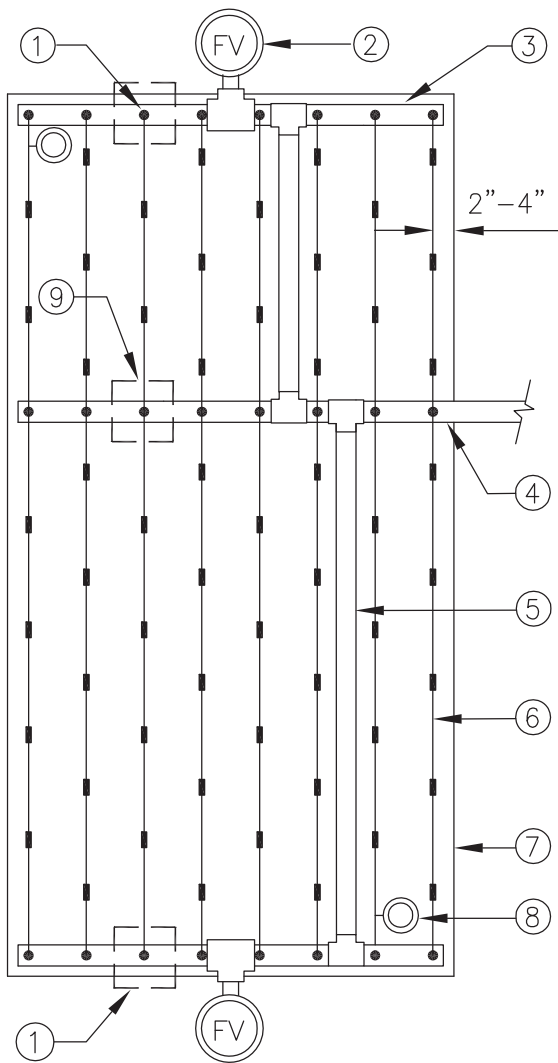

PLAN VIEW

- ① PVC TO DRIPLINE ELBOW CONNECTION. REFER TO INSET B
- ② FLUSH VALVE PLUMBED TO FLUSH MANIFOLD AT LOW POINT
- ③ 1" SCH. 40 PVC FLUSH MANIFOLD
- ④ PVC LATERAL LINE FROM VALVE. MINIMUM SIZE TO BE 1". SIZE AS FOLLOWS:
1" = 0-12 GPM
1.25" = 13-20 GPM
- ⑤ 1" PVC SUPPLY. EXTEND TO ENDS OF ZONE/EXHAUST HEADER
- ⑥ RAIN BIRD XFCV DRIPLINE
- ⑦ AREA PERIMETER
- ⑧ DRIPLINE OPERATION INDICATOR LOCATED AT THE ENDS OF EACH DRIPLINE ZONE. MIN. 2 PER VALVE
- ⑨ PVC TO DRIPLINE TEE CONNECTION. REFER TO INSET A
- ⑩ TWIST LOCK FITTING. TLF-TEE-0600 OR TLF-ELBW-0600
- ⑪ 1/2" POLYETHYLENE TUBING: RAIN BIRD XFD SERIES BLANK TUBING
- ⑫ TWIST LOCK FITTING: TLF-MPT6-0600
- ⑬ SCH 40 PVC TEE (SxSxT) WITH 1/2" FPT OUTLET

NOTE:

1. THE TOTAL LENGTH OF ALL INTERCONNECTED DRIP LINE OFF A SINGLE PVC SUPPLY LINE CONNECTION OR A SINGLE RUN OF DRIPLINE SHALL NOT EXCEED 300 FT
2. INSTALL DRIPLINE 2"-4" BELOW GRADE AND STAKE DOWN EVERY 4' OR AS REQUIRED

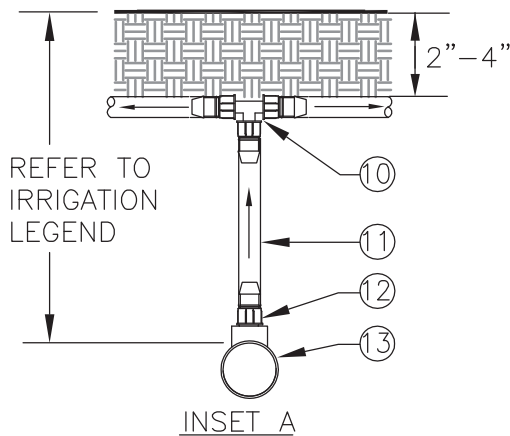

INSET A

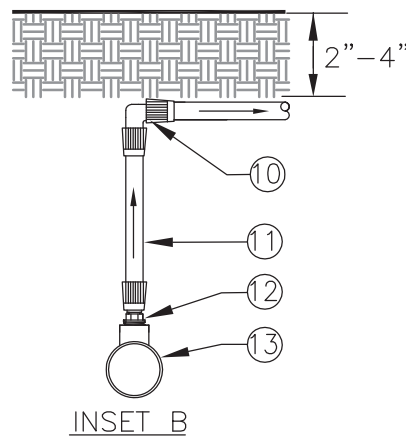

INSET B

APPROVED

3/8/23

DRAFT

DATE



CITY OF PITTSBURGH

NO.	DATE	REVISION	DRAWN BY:	CM
			CHECKED BY:	MK
			DATE:	2019-01-11
			SCALE:	NTS

STANDARD DETAIL

DRIPLINE - CENTER FEED

SHEET 1 OF 6

I-15

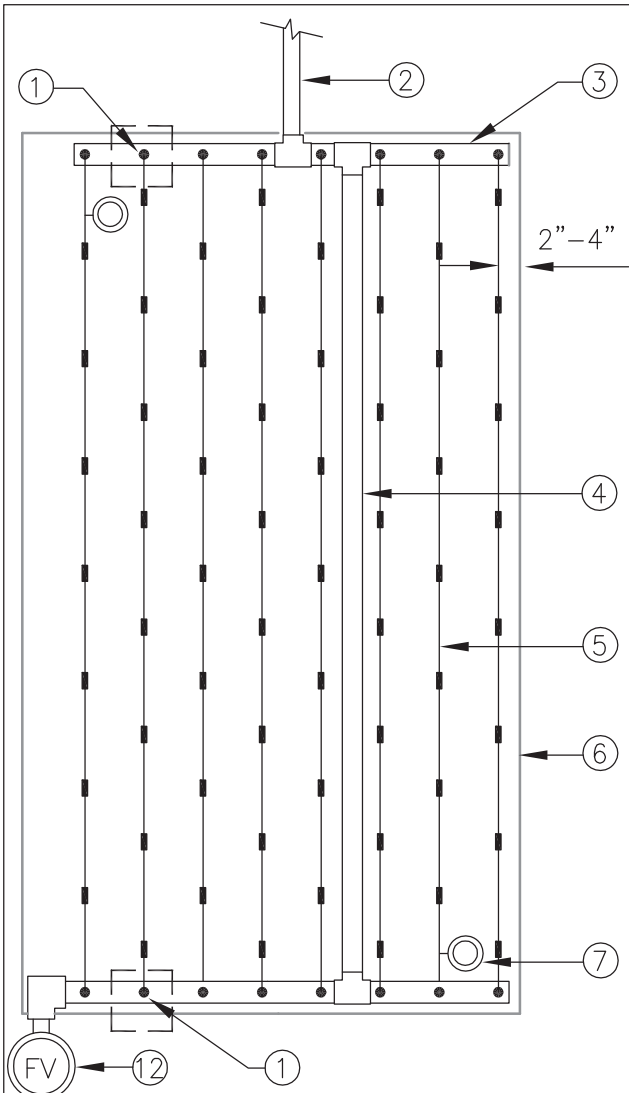

PLAN VIEW

- ① PVC TO DRIPLINE ELBOW CONNECTION. REFER TO INSET A
- ② PVC LATERAL LINE FROM VALVE. MINIMUM SIZE TO BE 1". SIZE AS FOLLOWS:
1" = 0-12 GPM
1.25" = 13-20 GPM
- ③ 1" SCH. 40 PVC FLUSH MANIFOLD
- ④ 1" PVC SUPPLY. EXTEND TO ENDS OF ZONE/EXHAUST HEADER
- ⑤ RAIN BIRD XFCV DRIPLINE
- ⑥ AREA PERIMETER
- ⑦ DRIPLINE OPERATION INDICATOR LOCATED AT THE ENDS OF EACH DRIPLINE ZONE. MIN. 2 PER VALVE
- ⑧ TWIST LOCK FITTING. TLF-ELBW-0600
- ⑨ 1/2" POLYETHYLENE TUBING: RAIN BIRD XFD SERIES BLANK TUBING
- ⑩ TWIST LOCK FITTING: TLF-MPT6-0600
- ⑪ SCH 40 PVC TEE (SxSxT) WITH 1/2" FPT OUTLET
- ⑫ FLUSH VALVE PLUMBED TO FLUSH MANIFOLD AT LOW POINT

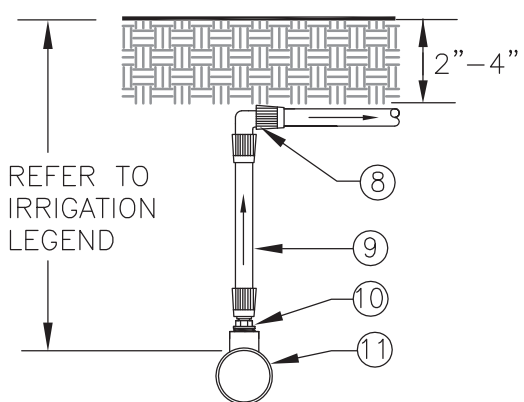

INSET A

- NOTE:
- 1. THE TOTAL LENGTH OF ALL INTERCONNECTED DRIP LINE OFF A SINGLE PVC SUPPLY LINE CONNECTION OR A SINGLE RUN OF DRIPLINE SHALL NOT EXCEED 300 FT
 - 2. INSTALL DRIPLINE 2"-4" BELOW GRADE AND STAKE DOWN EVERY 4' OR AS REQUIRED

APPROVED

3/8/23

DATE

DRAFT



NO.	DATE	REVISION	DRAWN BY:	CM
			CHECKED BY:	MK
			DATE:	2019-01-11
			SCALE:	NTS

STANDARD DETAIL

DRIPLINE - END FEED

SHEET 2 OF 6

I-15

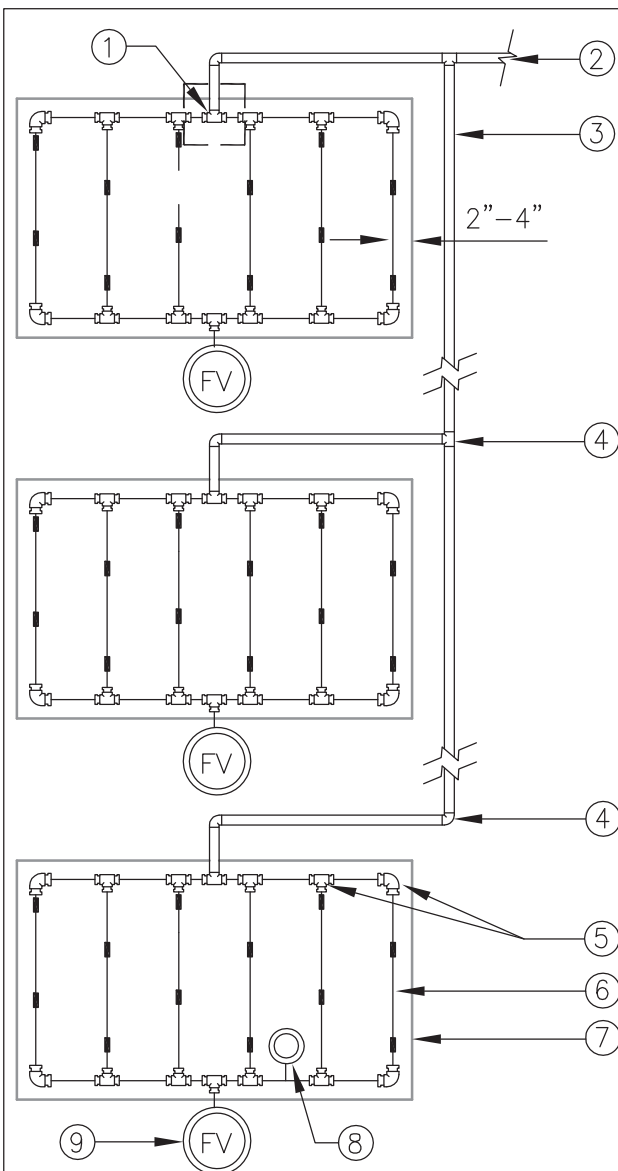

PLAN VIEW

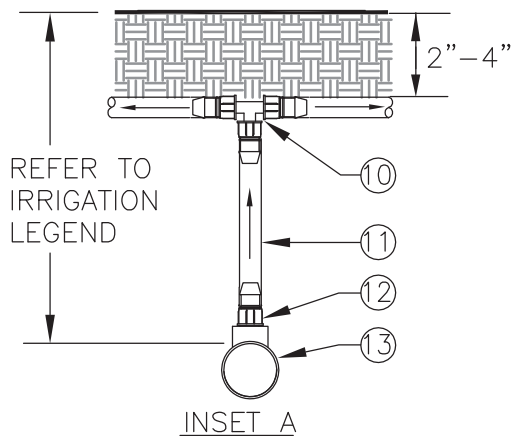

INSET A

- ① PVC TO DRIPLINE TEE CONNECTION. REFER TO INSET A
- ② PVC LATERAL LINE FROM VALVE. MINIMUM SIZE TO BE 1". SIZE AS FOLLOWS:
1" = 0-12 GPM
1.25" = 13-20 GPM
- ③ 1" PVC SUPPLY. EXTEND TO EACH ISLAND PLANTER
- ④ SCH. 40 PVC TEE OR ELBOW (SxSxS OR SxS)
- ④ 1" PVC SUPPLY. EXTEND TO ENDS OF ZONE/EXHAUST HEADER
- ⑤ TWIST LOCK FITTING. TLF-ELBW-0600 OR TLF-TEE-0600
- ⑥ RAIN BIRD XFCV DRIPLINE
- ⑦ AREA PERIMETER
- ⑧ DRIPLINE OPERATION INDICATOR LOCATED AT THE ENDS OF EACH DRIPLINE ZONE. MIN. 2 PER VALVE
- ⑨ FLUSH VALVE PLUMBED TO FLUSH MANIFOLD AT LOW POINT
- ⑩ TWIST LOCK FITTING. TLF-ELBW-0600 OR TLF-TEE0600
- ⑪ 1/2" POLYETHYLENE TUBING:
RAIN BIRD XFD SERIES BLANK TUBING
- ⑫ TWIST LOCK FITTING: TLF-MPT6-0600
- ⑬ SCH 40 PVC TEE (SxSxT) WITH 1/2" FPT OUTLET

NOTE:

- 1. THE TOTAL LENGTH OF ALL INTERCONNECTED DRIP LINE OFF A SINGLE PVC SUPPLY LINE CONNECTION OR A SINGLE RUN OF DRIPLINE SHALL NOT EXCEED 300 FT
- 2. INSTALL DRIPLINE 2"-4" BELOW GRADE AND STAKE DOWN EVERY 4' OR AS REQUIRED

APPROVED

3/8/23

DATE

DRAFT



CITY OF PITTSBURGH

NO.	DATE	REVISION	DRAWN BY:	CM
			CHECKED BY:	MK
			DATE:	2019-01-11
			SCALE:	NTS

STANDARD DETAIL

DRIPLINE - ISLAND LAYOUT

SHEET 3 OF 6

I-15

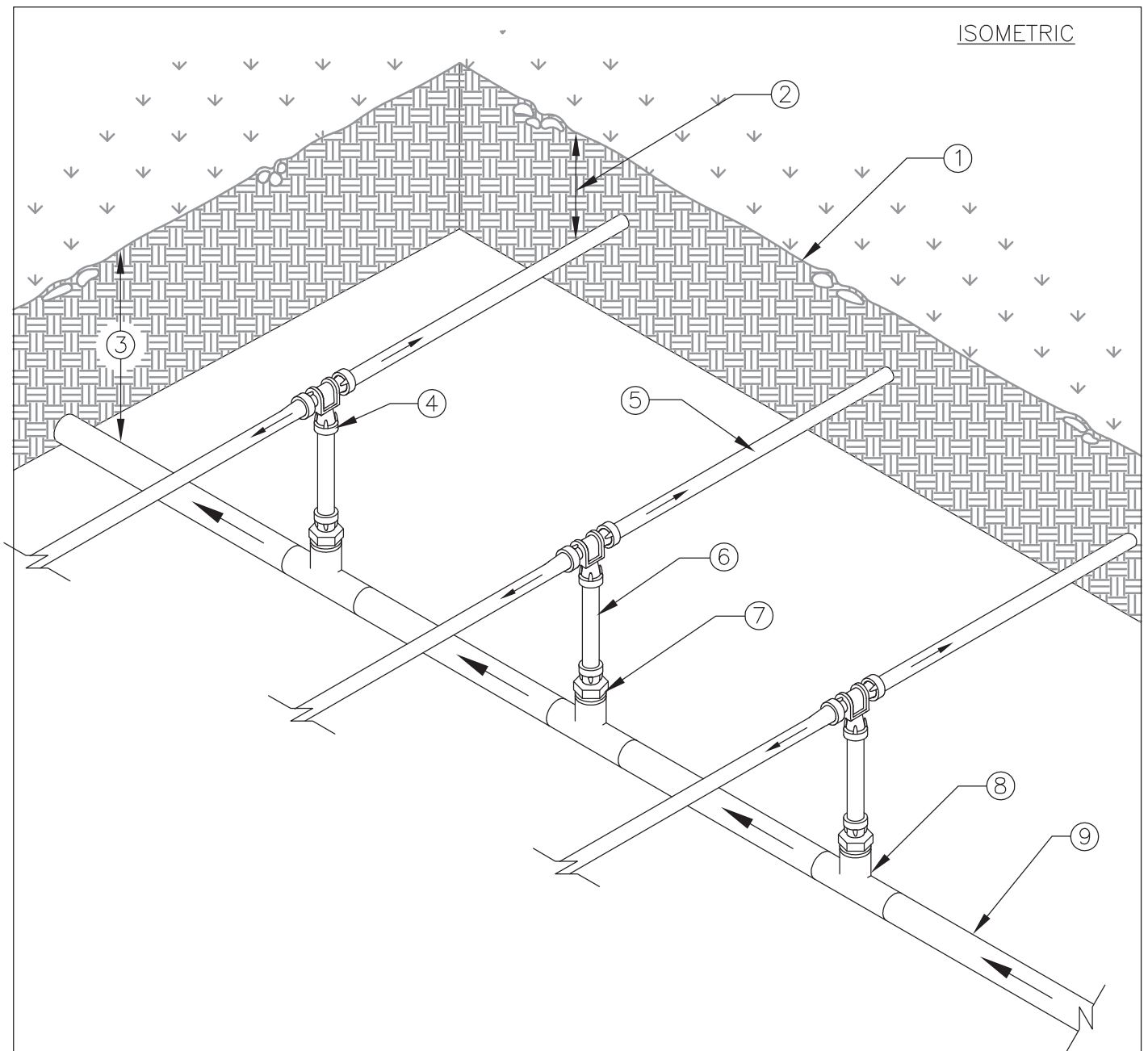

- ① FINISH GRADE
- ② DEPTH OF TUBING PER IRRIGATION LEGEND
- ③ DEPTH OF PVC LATERAL LINE PER IRRIGATION LEGEND
- ④ TWIST LOCK TEE FITTING. TLF-TEE-0600
- ⑤ RAIN BIRD XFCV DRIPLINE
- ⑥ 1/2" POLYETHYLENE TUBING: RAIN BIRD XFD SERIES BLANK TUBING
- ⑦ TWIST LOCK FITTING: TLF-MPT6-0600
- ⑧ SCH 40 PVC TEE WITH 1/2" FPT OUTLET
- ⑨ PVC LATERAL LINE FROM REMOTE CONTROL VALVE

APPROVED 

3/8/23

DRAFT

DATE



CITY OF PITTSBURGH

NO.	DATE	REVISION

DRAWN BY:	CM
CHECKED BY:	MK
DATE:	2019-01-11
SCALE:	NTS

STANDARD DETAIL

DRIPLINE - CENTER FEED MANIFOLD

SHEET 4 OF 6

I-15

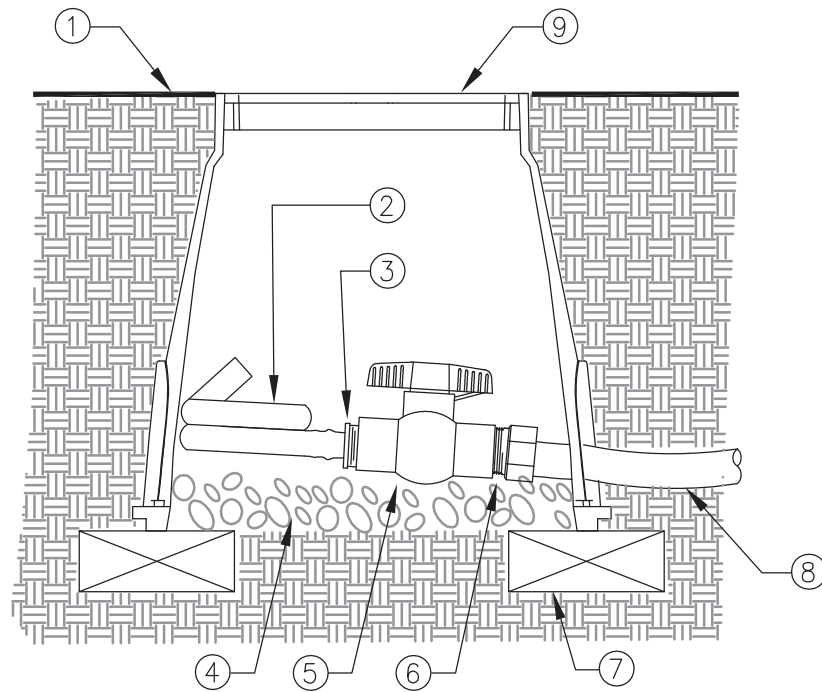

NOTE:

ALLOW A MINIMUM 18" OF DRIPLINE HOSE IN VALVE BOX IN ORDER TO DIRECT FLUSHED WATER OUTSIDE VALVE BOX

- ① FINISH GRADE
- ② 1/2" POLYETHYLENE TUBING:
RAIN BIRD XFD SERIES BLANK TUBING. MIN. 18" IN LENGTH
- ③ TWIST LOCK MALE ADAPTER. TLF-MPT6-0600
- ④ PEA GRAVEL SUMP (4" DEEP)
- ⑤ 1/2" SCH. 40 THREADED BALL VALVE
- ⑥ 1/2" SCH. 40 MALE ADAPTER
- ⑦ BRICK-2 TOTAL
- ⑧ 1/2" IPS PVC HOSE FROM DRIPLINE OR EXHAUST HEADER
- ⑨ 6" ROUND PLASTIC VALVE BOX

APPROVED

3/8/23

DRAFT

DATE



CITY OF
PITTSBURGH

NO.	DATE	REVISION	DRAWN BY:	CM
			CHECKED BY:	MK
			DATE:	2019-01-11
			SCALE:	NTS

STANDARD DETAIL

DRIPLINE - FLUSH POINT

SHEET 5 OF 6

I-15

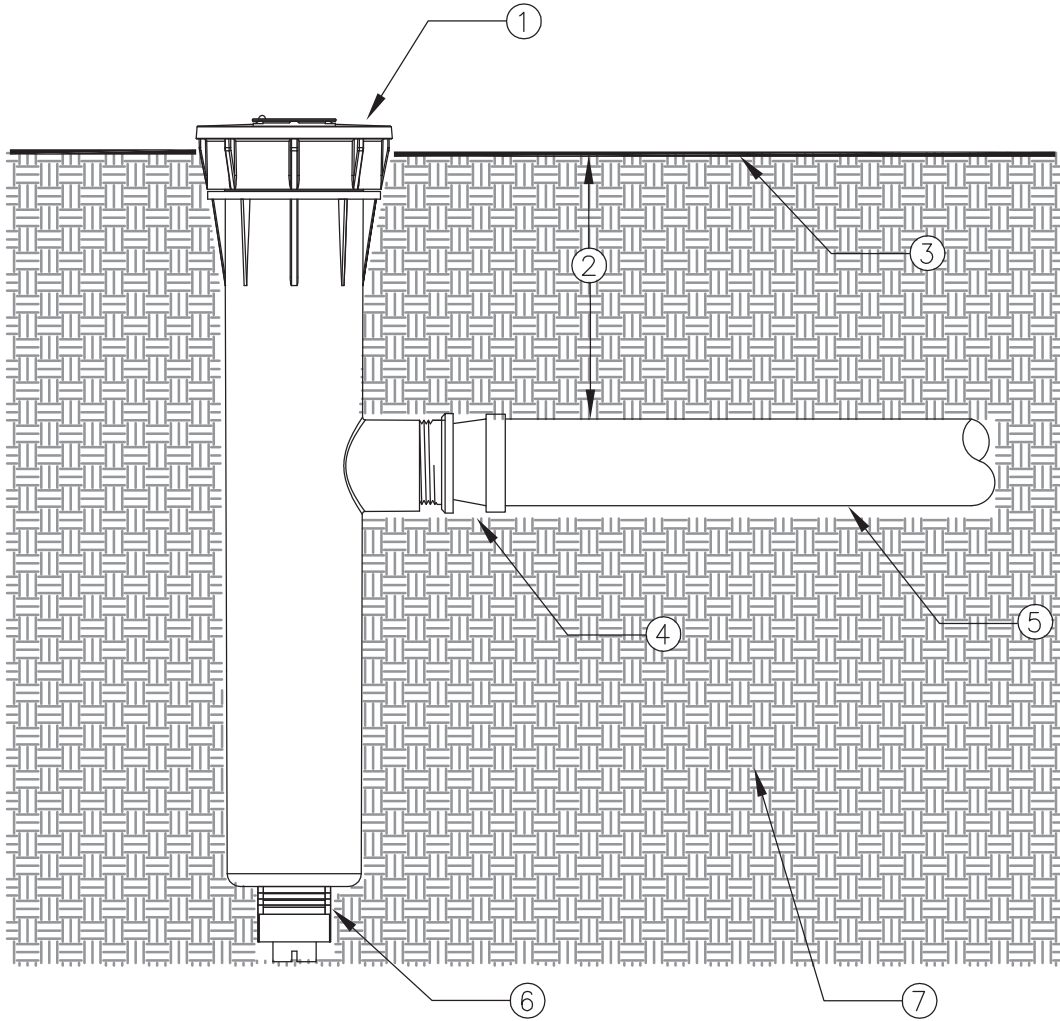

SECTION/ELEVATION

- ① RAIN BIRD 6" POP UP SPRINKLER WITH SIDE INLET (MODEL 1806-SI WITH 5' NOZZLE (MODEL 5Q) TURNED COMPLETELY OFF WITH ADJUSTMENT SCREW. SPRINKLER SHALL OPERATE AS THE DRIPLINE INDICATOR. USE A MINIMUM OF ONE PER ZONE AND LOCATED AT END OF ZONE
- ② DEPTH OF DRIPLINE. REFER TO IRRIGATION LEGEND
- ③ FINISH GRADE
- ④ RAIN BIRD TWIST LOCK MALE ADAPTER FITTING: TLF-MPT6-0600
- ⑤ DRIPLINE
- ⑥ KEEP PLUG IN SPRINKLER. ONLY USE SIDE INLET
- ⑦ SOIL BACKFILL

APPROVED

3/8/23

DRAFT

DATE



CITY OF
PITTSBURGH

NO.	DATE	REVISION

DRAWN BY:	CM
CHECKED BY:	MK
DATE:	2019-01-11
SCALE:	NTS

STANDARD DETAIL

DRIPLINE - OPERATION INDICATOR

SHEET 6 OF 6

I-15

NOTES:

1. ALL SIGNS MUST BE STAMPED "PROPERTY OF THE CITY OF PITTSBURG," AND DATED
2. LETTER STYLE, CITY LOGO, AND BORDER COLOR ARE REFLECTIVE WHITE AGAINST PURPLE, REFLECTIVE SHEETING
3. 1/4" WHITE BORDER OFFSET 1/4" FROM EDGE OF SIGN

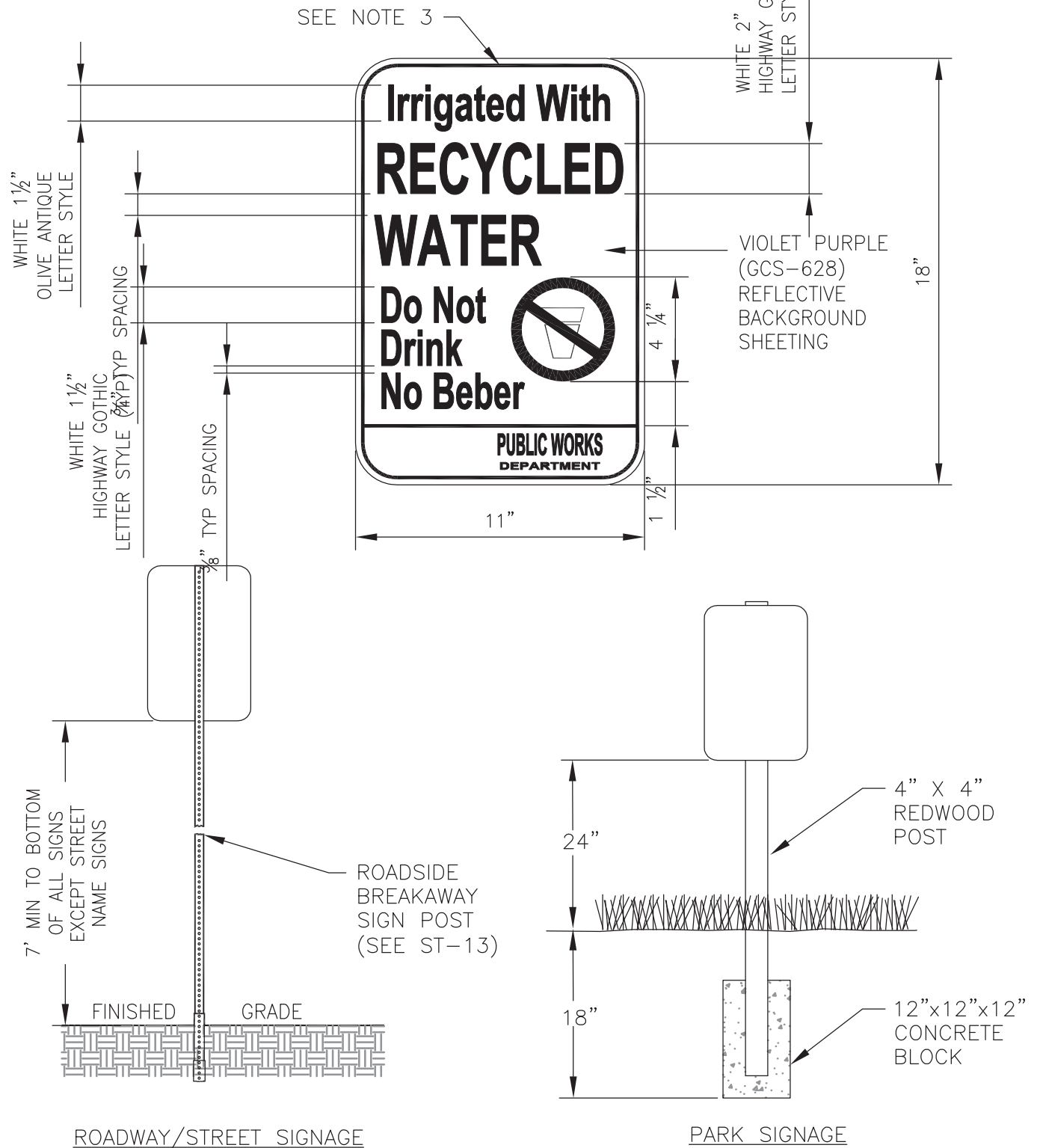

APPROVED

3/8/23

DATE

DRAFT



CITY OF PITTSBURG

NO.	DATE	REVISION

DRAWN BY:	CM
CHECKED BY:	MK
DATE:	2019-01-11
SCALE:	NTS

STANDARD DETAIL

RECYCLED WATER SIGN

SHEET 1 OF 1

I-16

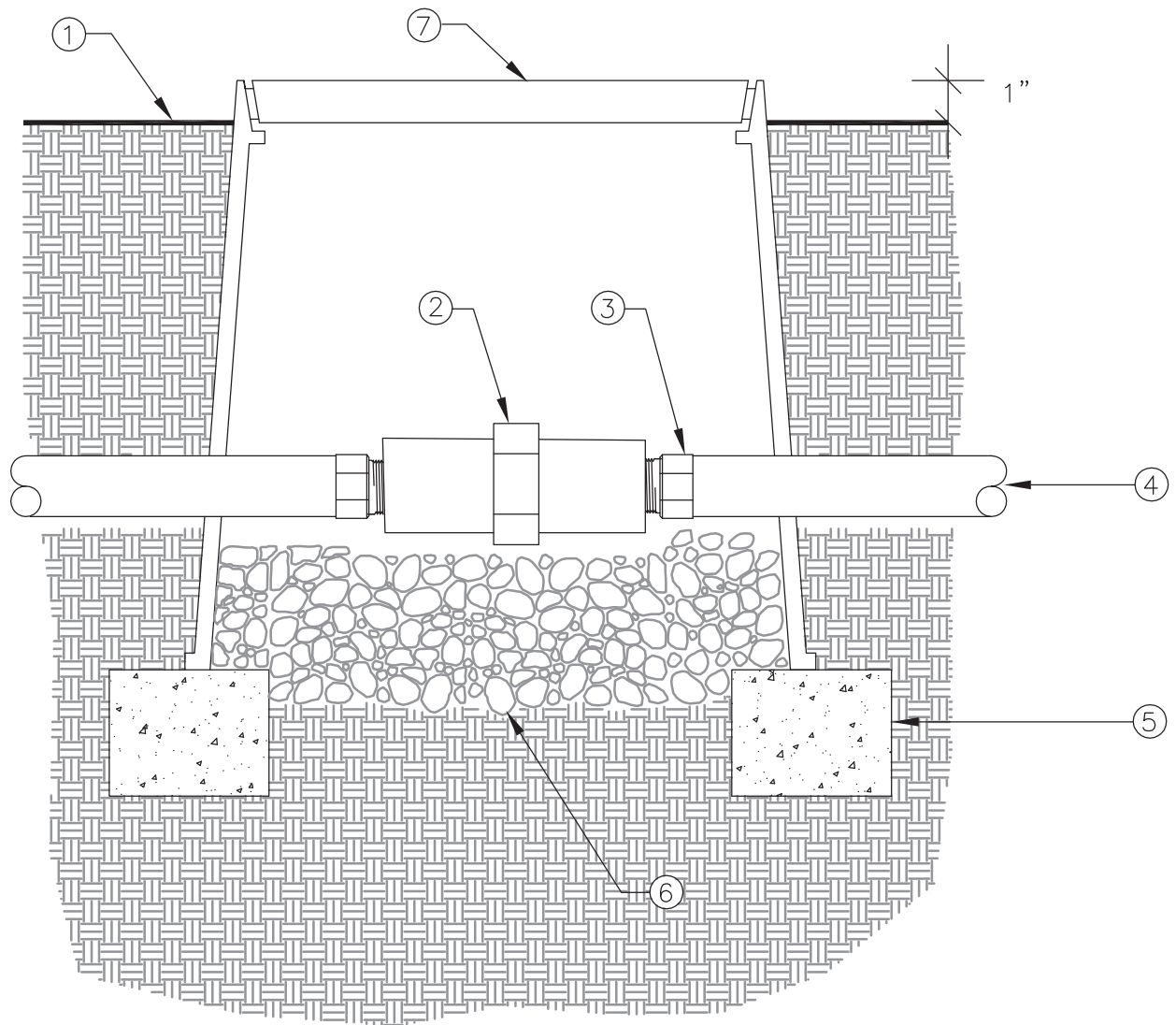

SECTION/ELEVATION

- ① FINISH GRADE
- ② INLINE SPRING OR SWING LOADED CHECK VALVE. MATCH SIZE OF LATERAL LINE
- ③ SCHEDULE 40 PVC MALE ADAPTER. 2 TOTAL
- ④ PVC LATERAL LINE
- ⑤ BRICK-2 TOTAL
- ⑥ PEA GRAVEL OR 3/4" DRAIN ROCK - 4" DEEP (NO SOIL IN VALVE BOX)
- ⑦ 10" ROUND VALVE BOX

APPROVED

3/8/23

DRAFT

DATE



CITY OF PITTSBURGH

NO.	DATE	REVISION	DRAWN BY:	CM
			CHECKED BY:	MK
			DATE:	2019-01-11
			SCALE:	NTS

STANDARD DETAIL

LATERAL LINE CHECK VALVE

SHEET 1 OF 1

I-17

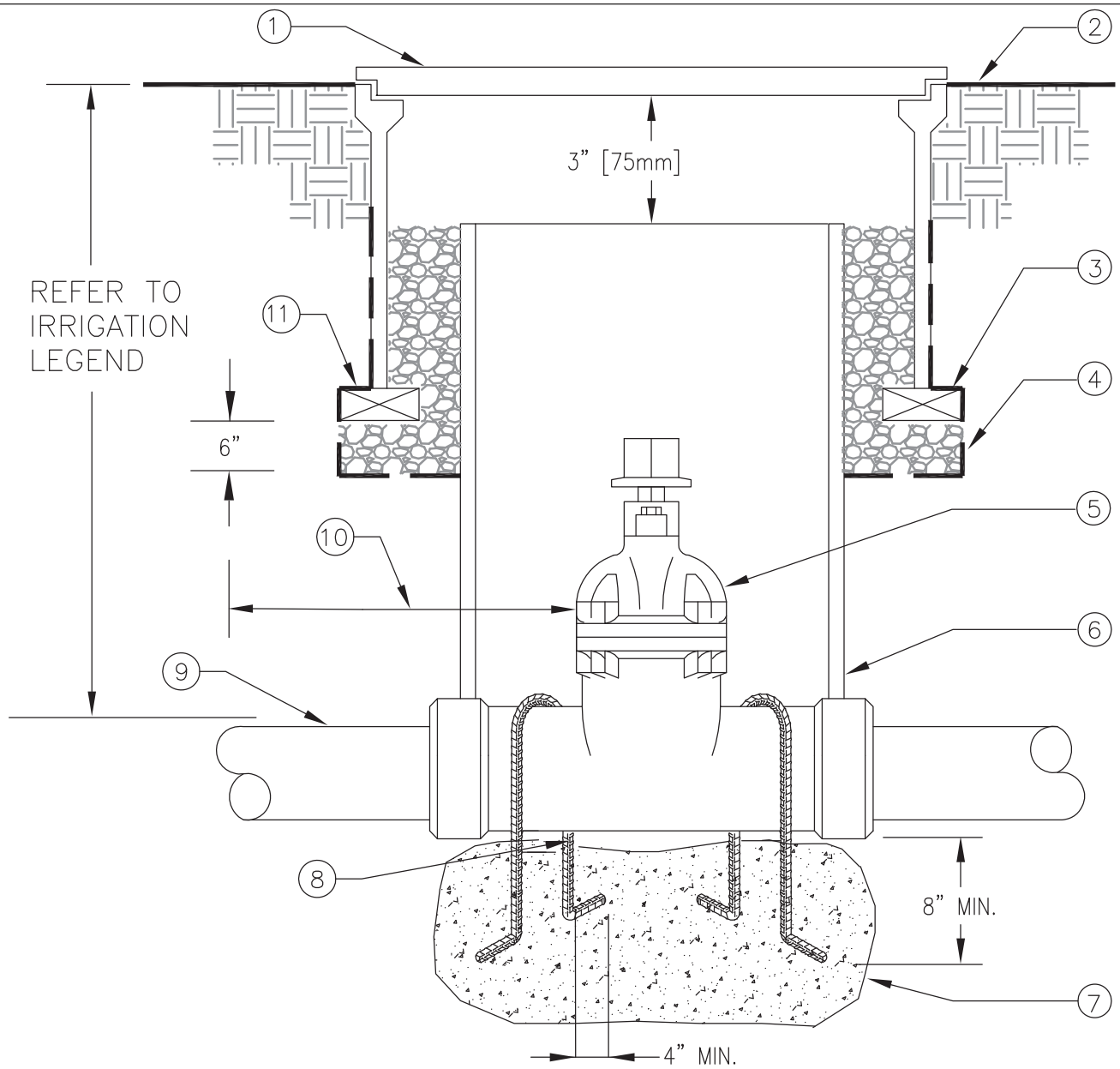

- ① 10" ROUND PLASTIC VALVE BOX WITH BOLT DOWN T-LID
- ② FINISH GRADE
- ③ BRICK—2 TOTAL
- ④ PEA GRAVEL OR 3/4" DRAIN ROCK — 4" DEEP BELOW VALVE (NO SOIL IN VALVE BOX)
- ⑤ GATE VALVE WITH 2" OPERATING NUT
- ⑥ 6" PVC PIPE. CUT OUT AROUND PIPE
- ⑦ CONCRETE THRUST BLOCK — 18" CUBE
- ⑧ #4 REBAR—BEND OVER VALVE BODY BEND EACH END
- ⑨ PVC MAIN LINE
- ⑩ PROVIDE A MINIMUM OF 10' BETWEEN GATE VALVE AND MAIN LINE TEE OR ELBOW
- ⑪ 19 GAUGE 1/2" SQUARE WIRE MESH. WRAP UP SIDE OF BOX

APPROVED  DATE 3/8/23

DRAFT

 CITY OF PITTSBURGH	NO.	DATE	REVISION	DRAWN BY: CM	STANDARD DETAIL GATE VALVE — 4" & LARGER	SHEET 1 OF 2 I-18
				CHECKED BY: MK		
				DATE: 2019-01-11		
				SCALE: NTS		

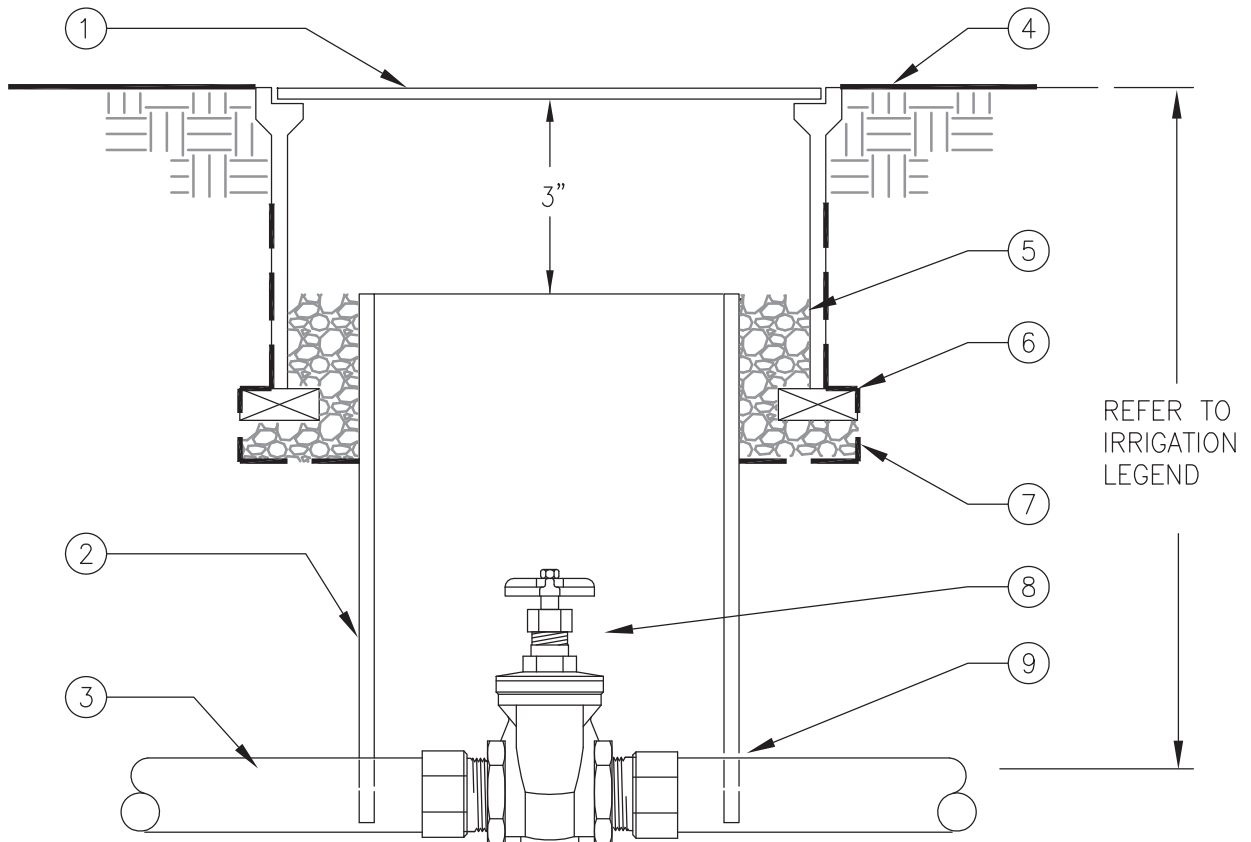

- ① 10" ROUND PLASTIC VALVE BOX WITH BOLT DOWN LID
- ② 8" CLASS 160 OR SCHEDULE 40 PVC PIPE (NOTCH TO FIT OVER MAIN LINE PIPE)
- ③ PVC MAIN LINE
- ④ FINISH GRADE
- ⑤ PEA GRAVEL OR 3/4" DRAIN ROCK - 4" DEEP (NO SOIL IN VALVE BOX)
- ⑥ BRICK-2 TOTAL
- ⑦ 19 GAUGE 1/2" SQUARE WIRE MESH
- ⑧ GATE VALVE WITH X-TOP HANDLE
- ⑨ MALE ADAPTER. REFER TO LEGEND FOR FITTING TYPE

APPROVED

3/8/23

DRAFT

DATE



CITY OF
PITTSBURG

NO.	DATE	REVISION	DRAWN BY:	CM
			CHECKED BY:	MK
			DATE:	2019-01-11
			SCALE:	NTS

STANDARD DETAIL

GATE VALVE - 3" & SMALLER

SHEET 2 OF 2

I-18

BROOKWATER
 IRRIGATION CONSULTANTS
 TWO CROW CANYON COURT, SUITE 100
 SAN RAMON, CALIFORNIA 94583
 TEL 925.855.0417 FAX 925.855.0357
 E-MAIL JANET@BROOKWATER.COM

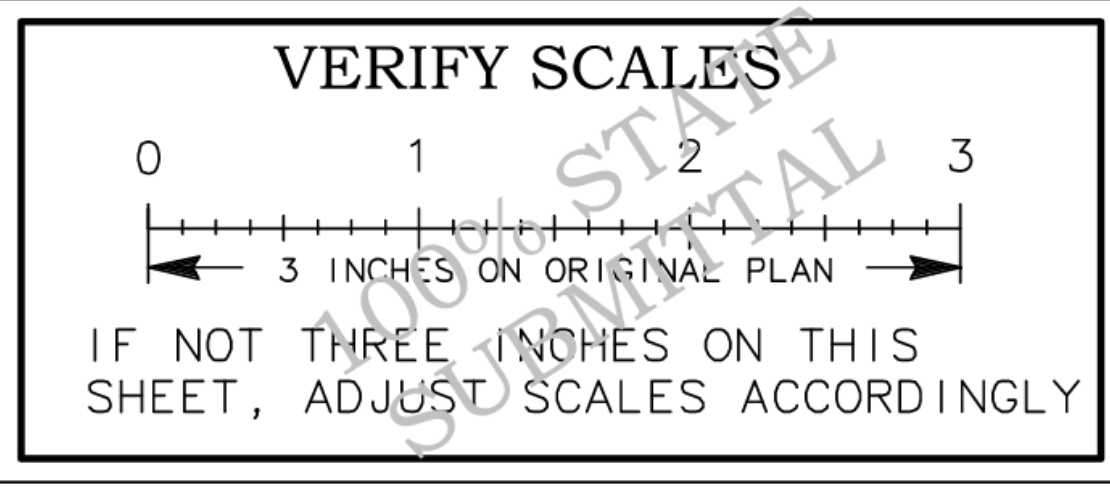

Dist	COUNTY	ROUTE	POST MILES TOTAL PROJECT	SHEET No.	TOTAL SHEETS
04	CC	04	23.0-23.4	55	79

REGISTERED CIVIL ENGINEER DATE _____
 PLANS APPROVAL DATE _____
 THE STATE OF CALIFORNIA OR ITS OFFICERS OR AGENTS SHALL NOT BE RESPONSIBLE FOR THE ACCURACY OR COMPLETENESS OF SCANNED COPIES OF THIS PLAN SHEET.



CITY OF PITTSBURG
 65 CIVIC AVENUE
 PITTSBURG, CA 94565

- LEGEND:**
- SUB-SURFACE DRIP LINE (FOR BIORETENTION STRIP). NETAFIM TLCV6-12025. 2" COVER (12" EMITTER SPACING, 0.92 GPH PER EMITTER)
 - + + + ROCK MULCH, 3" DEPTH

DESIGNED BY DANVE JOHNSON
 CHECKED BY JOHN SAMUELSON
 DATE 1/9/2024
 REVISIONS: 1/9/2024

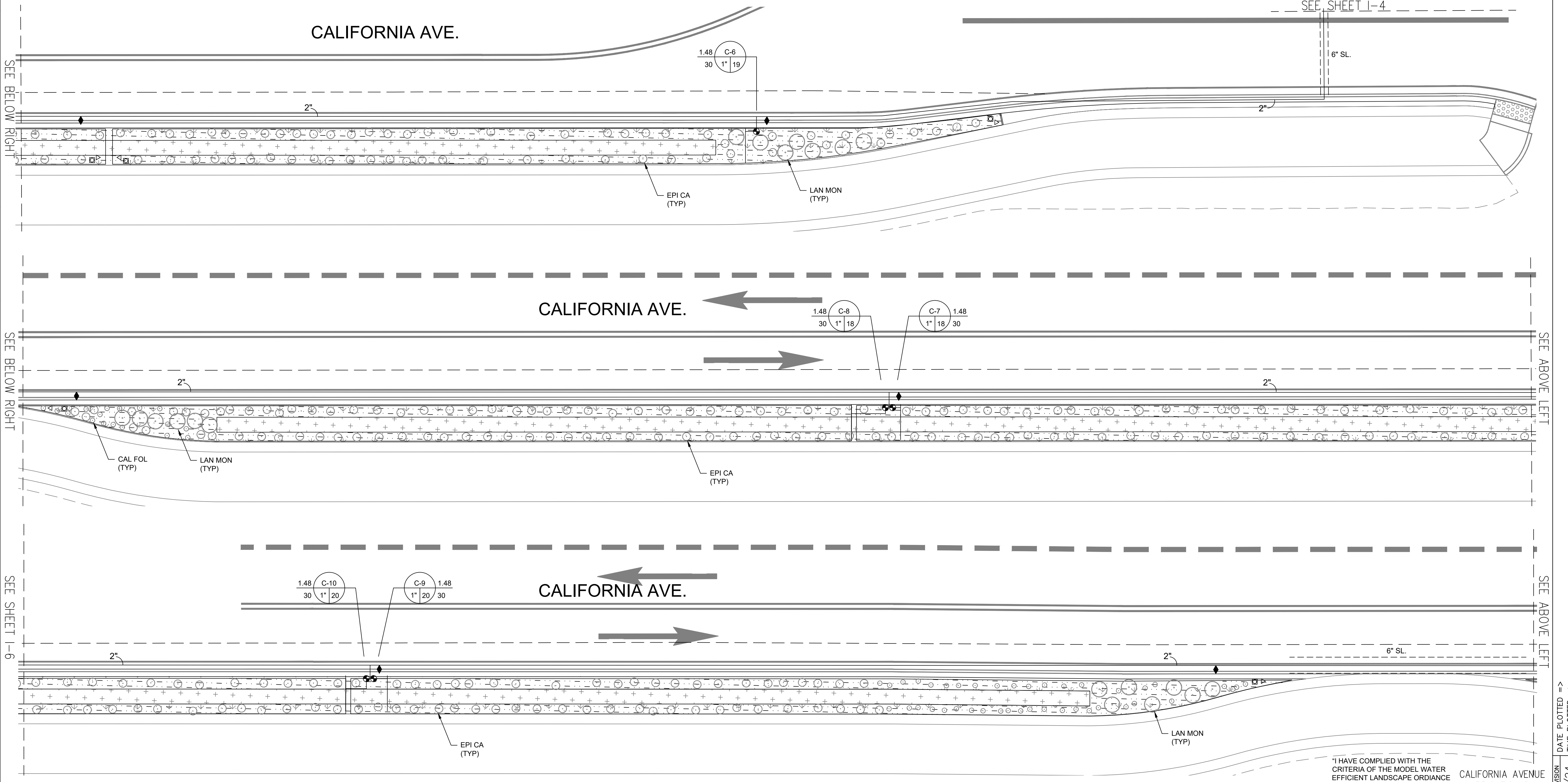

"I HAVE COMPLIED WITH THE CRITERIA OF THE MODEL WATER EFFICIENT LANDSCAPE ORDINANCE AND HAVE APPLIED THEM FOR THE EFFICIENT USE OF WATER IN THE IRRIGATION DESIGN PLAN."
 CALIFORNIA AVENUE IRRIGATION PLAN 1-5
 DATE PLOTTED => 1/9/24
 TIME PLOTTED =>

STATE OF CALIFORNIA - DEPARTMENT OF TRANSPORTATION
Caltrans
 FUNCTIONAL SUPERVISOR
 DESIGNED BY
 CHECKED BY
 DATE
 1/9/2024
 1/9/2024
 REVISED BY
 DATE REVISED

BROOKWATER
 IRRIGATION CONSULTANTS
 TWO CROW CANYON COURT, SUITE 100
 SAN RAMON, CALIFORNIA 94583
 TEL. 925.855.0417 FAX 925.855.0357
 E-MAIL JANET@BROOKWATER.COM

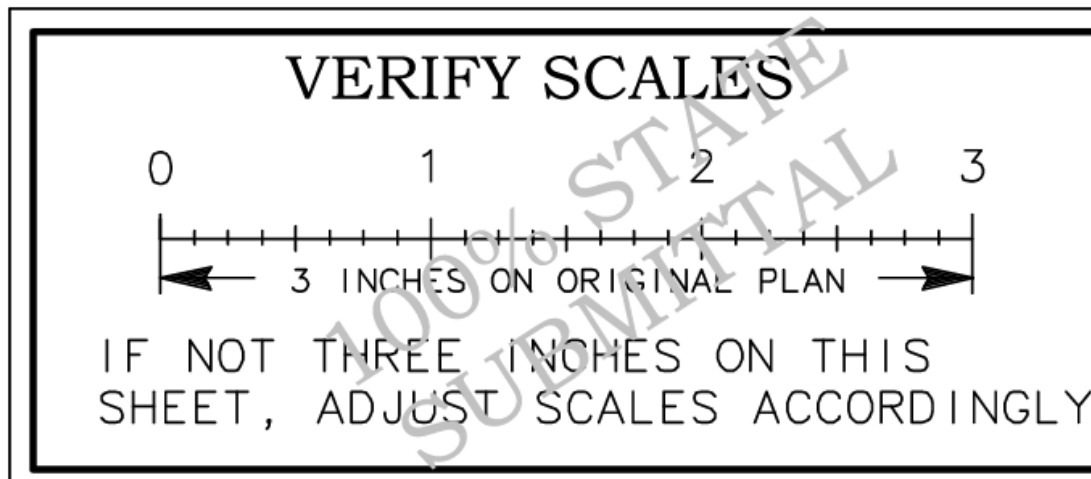

LEGEND:

- SUB-SURFACE DRIP LINE (FOR BIORETENTION STRIP). NETAFIM TLCV6-12025. 2" COVER (12" EMITTER SPACING, 0.92 GPH PER EMITTER)
- ROCK MULCH, 3" DEPTH

Dist	COUNTY	ROUTE	POST MILES TOTAL PROJECT	SHEET No.	TOTAL SHEETS
04	CC	04	23.0-23.4	55	79

REGISTERED CIVIL ENGINEER _____ DATE _____

PLANS APPROVAL DATE _____

THE STATE OF CALIFORNIA OR ITS OFFICERS OR AGENTS SHALL NOT BE RESPONSIBLE FOR THE ACCURACY OR COMPLETENESS OF SCANNED COPIES OF THIS PLAN SHEET.

CITY OF PITTSBURG
 65 CIVIC AVENUE
 PITTSBURG, CA 94565

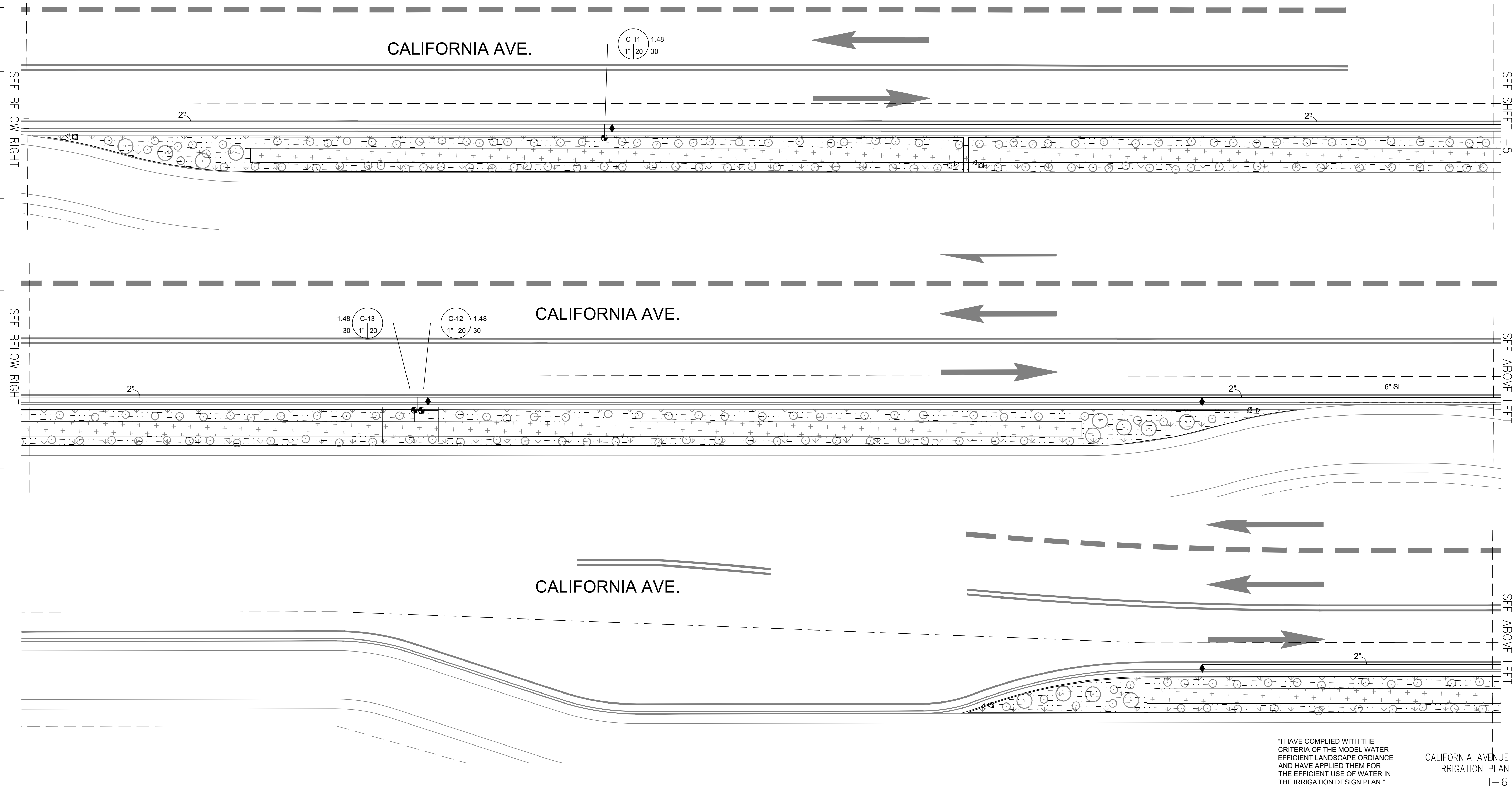

"I HAVE COMPLIED WITH THE CRITERIA OF THE MODEL WATER EFFICIENT LANDSCAPE ORDINANCE AND HAVE APPLIED THEM FOR THE EFFICIENT USE OF WATER IN THE IRRIGATION DESIGN PLAN."

CALIFORNIA AVENUE
 IRRIGATION PLAN
 I-6

DATE PLOTTED =>
 LAST REVISION