

**TRAFFIC & LIGHTING NOTES**

The purpose of these Traffic & Lighting Notes is to serve as the basis for design of fixed lighting for roadways, bike ways, pedestrian ways and outside parking lots. The following standard practice deals entirely with lighting and does not give advice on construction practices or methods.

It is neither intended as, nor does it establish a legal standard for roadway lighting systems. Its purpose is to provide recommended practices for designing new roadway lighting systems, and it is not intended to be applied to existing lighting systems until such systems are redesigned or modified.

In general, the lighting requirements shall be as described in the Illuminating Engineering Society of North America, RP-8 Report (IESNA, RP-8). When the IESNA publishes lighting requirements specifically for Light Emitting Diode (LED) lighting, the new LED requirements shall be utilized.

The lighting system of a specific road section should accommodate the visual needs of night traffic (vehicular and pedestrian) and be expressed in terms clearly understandable by lighting designers, traffic engineers and City of Pittsburg engineering department personnel.

The visual environmental needs along the roadway are described in the IESNA, RP-8 report in terms of pavement luminance, luminance uniformity and disability veiling glare provided by the system light sources.

The design of a roadway lighting system involves consideration of visibility, economics, aesthetics and environmental conditions as well as appropriate equipment and material.

The design shall generally follow these steps:

1. Determination of roadway classification and abutting land uses along the specific road section to be lighted.
2. Selection of the level and uniformity of pavement luminance for roadway and/or land use.
3. Selection of luminaires and light sources as indicated in City of Pittsburg Standard Detail T-5.
4. Calculation of pole spacing for the various luminaire/lamp type combinations allowed in City of Pittsburg Standard Detail T-5 based on the luminance values selected for the roadway to be lighted.

Determination of roadway classification and abutting land use, level and uniformity of illumination shall be determined from the IESNA, RP-8 report.

The lighting designer shall submit to the City, lighting calculations from an approved lighting software program, that clearly indicate the Average Luminance and Average/Minimum Luminance Uniformity ratio of the roadway surface along the desired roadway or within the project area. Lighting programs may be "AGI-32", or approved equal.



APPROVED \_\_\_\_\_

**3/8/23**

DRAFT

DATE

 CITY OF PITTSBURG	NO.	DATE	REVISION	DRAWN BY:	STANDARD DETAIL  TRAFFIC & LIGHTING NOTES	SHEET 1 OF 1  T-1
	1	2011-04-06	UPDATED STD DETAIL	CHECKED BY: MK		
				DATE: 2019-01-11		
				SCALE: NONE		

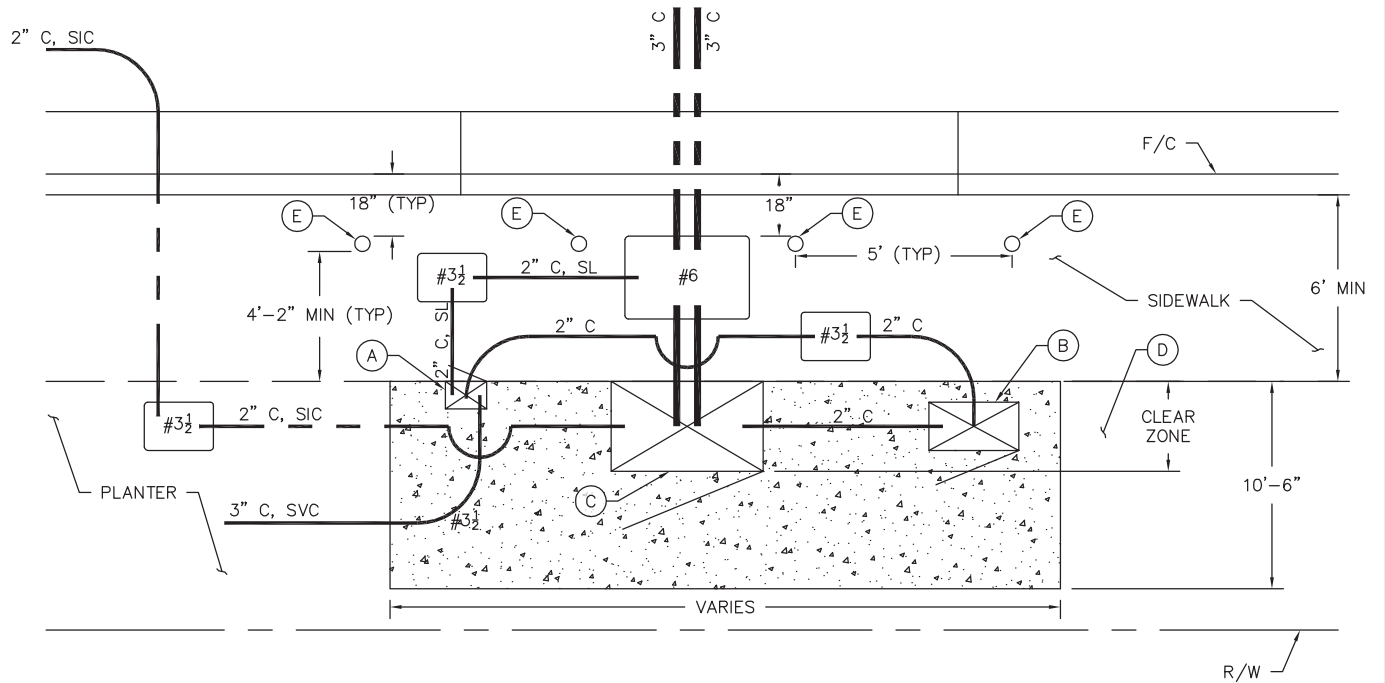

PLAN VIEW  
SCALE: NTS

- (A) TYPE III-AF SERVICE EQUIPMENT ENCLOSURE
- (B) UNINTERRUPTIBLE POWER SUPPLY (UPS)
- (C) TYPE "P" CONTROLLER CABINET PER CALTRANS STANDARD PLAN ES-3A (3'-8½" WIDE x 2'-2" LONG x 4'-7" TALL)
- (D) NO JOINT TRENCH FACILITIES IN CLEAR ZONE
- (E) INSTALL FIXED BOLLARD PER CITY STANDARD DETAIL L-8

ABBREVIATIONS

- C CONDUIT
- F/C FACE OF CURB
- R/W RIGHT-OF-WAY
- SVC SERVICE
- SIC SIGNAL INTERCONNECT
- SL STREET LIGHT
- # CALTRANS PULL BOX SIZE

APPROVED

3/8/23

DATE

DRAFT



CITY OF  
PITTSBURG

NO.	DATE	REVISION	DRAWN BY:	JM
1	2019-01-11	ADDED BOLLARDS	CHECKED BY:	MK
			DATE:	2019-01-11
			SCALE:	NTS

STANDARD DETAIL  
TRAFFIC SIGNAL INSTALLATION  
CONTROLLER ASSEMBLY & ELECTRIC  
SERVICE CONCEPTUAL LAYOUT

SHEET 1 OF 2

T-2

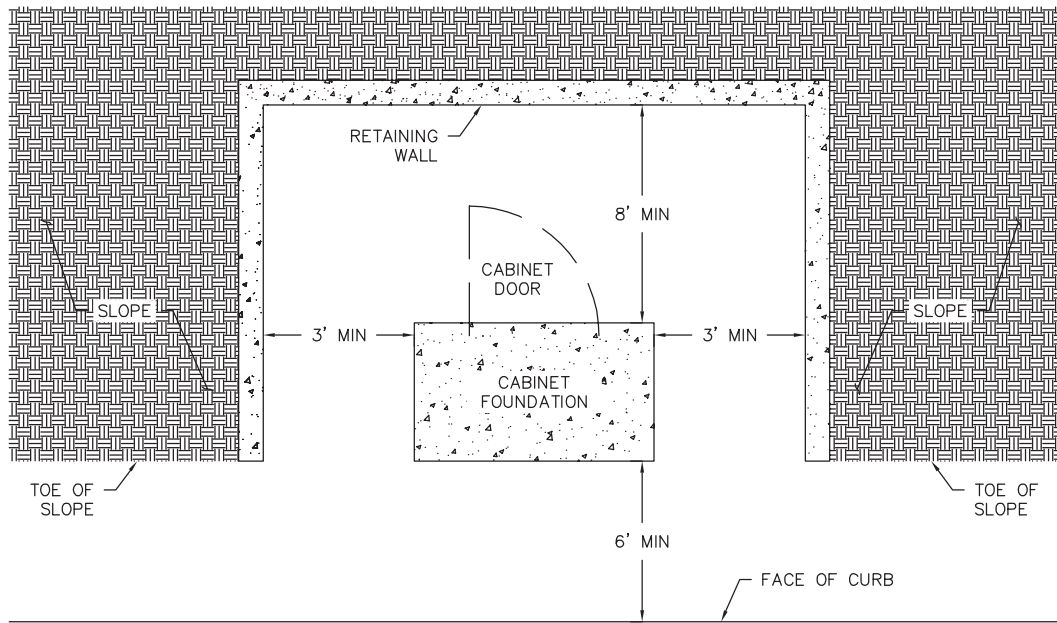

PLAN VIEW  
SCALE: NTS

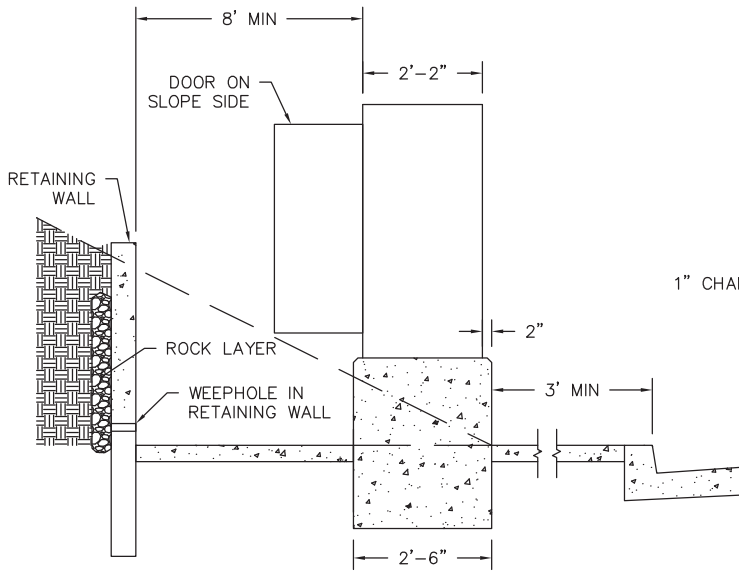

SIDE VIEW  
SCALE: NTS

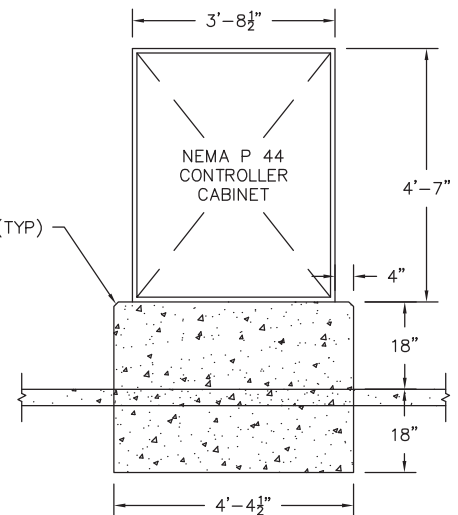

FRONT VIEW  
SCALE: NTS

PCC FOUNDATION FOR TYPE P CABINET  
TOE OF SLOPE LOCATION

APPROVED 

3/8/23

DRAFT

DATE



CITY OF  
PITTSBURGH

NO.	DATE	REVISION	DRAWN BY:	JM
1	2019-01-11	ADDED RETAINING WALL, DOOR ON SLOPE SIDE	CHECKED BY:	MK
			DATE:	2019-01-11
			SCALE:	NTS

STANDARD DETAIL  
TRAFFIC SIGNAL INSTALLATION  
CONTROLLER CABINET FOUNDATION  
AT SLOPE LOCATIONS

SHEET 2 OF 2

T-2

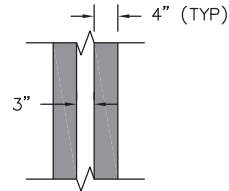
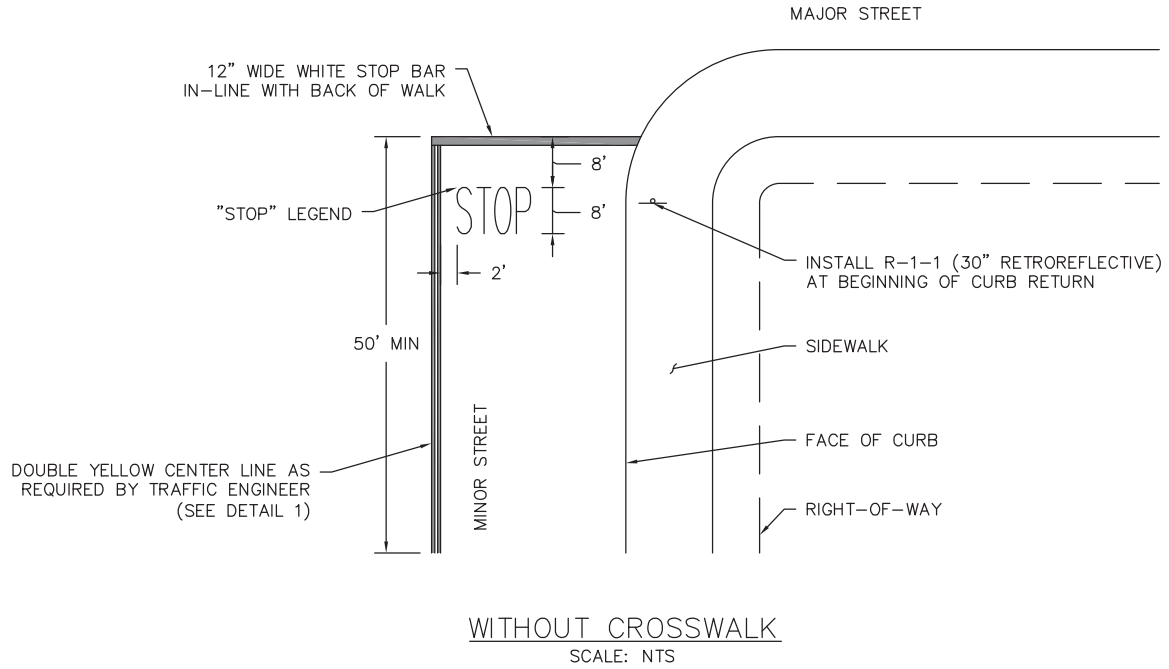

1 CENTER LINE STRIPING DETAIL

NOTES

1. TRAFFIC STRIPING PAVEMENT MARKINGS SHALL BE REFLECTORIZED THERMOPLASTIC AND SHALL CONFORM TO THE CURRENT CALTRANS STANDARD SPECIFICATIONS.
2. STOP BAR LOCATION OTHER THAN INDICATED SHALL REQUIRE APPROVAL AND SHALL BE ALLOWED ONLY WHERE INTERSECTION GEOMETRY OR SIGHT DISTANCE WARRANT IT.

LEGEND



THERMOPLASTIC PAVEMENT MARKING

APPROVED 

3/8/23

DRAFT

DATE



CITY OF  
PITTSBURG

NO.	DATE	REVISION	DRAWN BY:	AW
1	2019-01-11	SIGN LOCATION	CHECKED BY:	MK
			DATE:	2019-01-11
			SCALE:	NTS

STANDARD DETAIL

STOP BAR

SHEET 1 OF 2

T-3

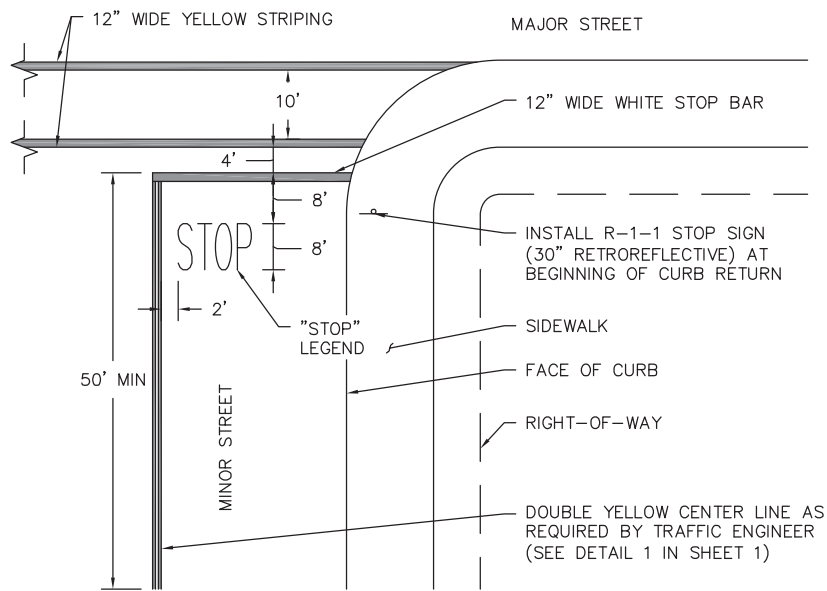

AT SCHOOL CROSSWALK  
SCALE: NTS

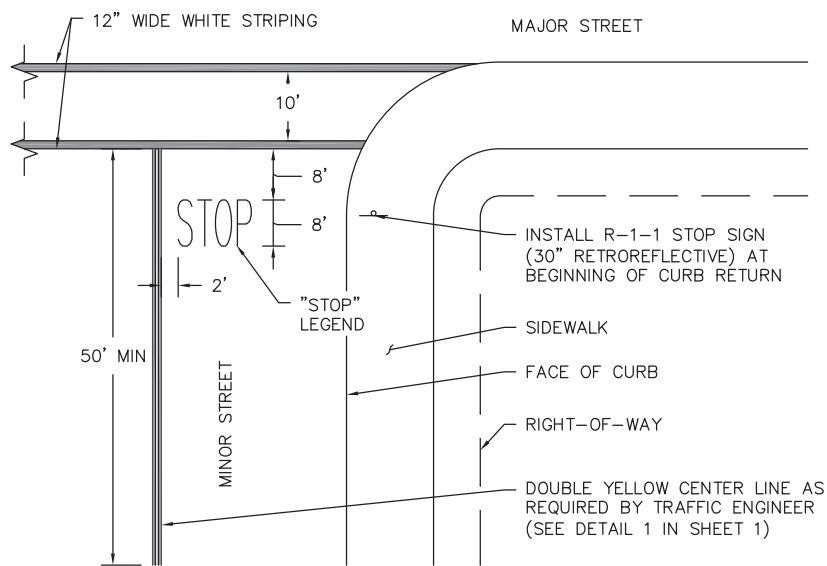

AT NON-SCHOOL CROSSWALK  
SCALE: NTS

LEGEND

 THERMOPLASTIC PAVEMENT MARKING

NOTES

1. TRAFFIC STRIPING PAVEMENT MARKINGS SHALL BE REFLECTORIZED THERMOPLASTIC AND SHALL CONFORM TO THE CURRENT CALTRANS STANDARD SPECIFICATIONS.
2. STOP BAR LOCATION OTHER THAN INDICATED SHALL REQUIRE APPROVAL AND SHALL BE ALLOWED ONLY WHERE INTERSECTION GEOMETRY OR SIGHT DISTANCE WARRANT IT.

APPROVED \_\_\_\_\_



3/8/23

DATE

DRAFT



CITY OF  
PITTSBURG

NO.	DATE	REVISION	DRAWN BY:	AW
			CHECKED BY:	MK
			DATE:	2019-01-11
			SCALE:	NTS

STANDARD DETAIL

STOP BAR

SHEET 2 OF 2

T-3

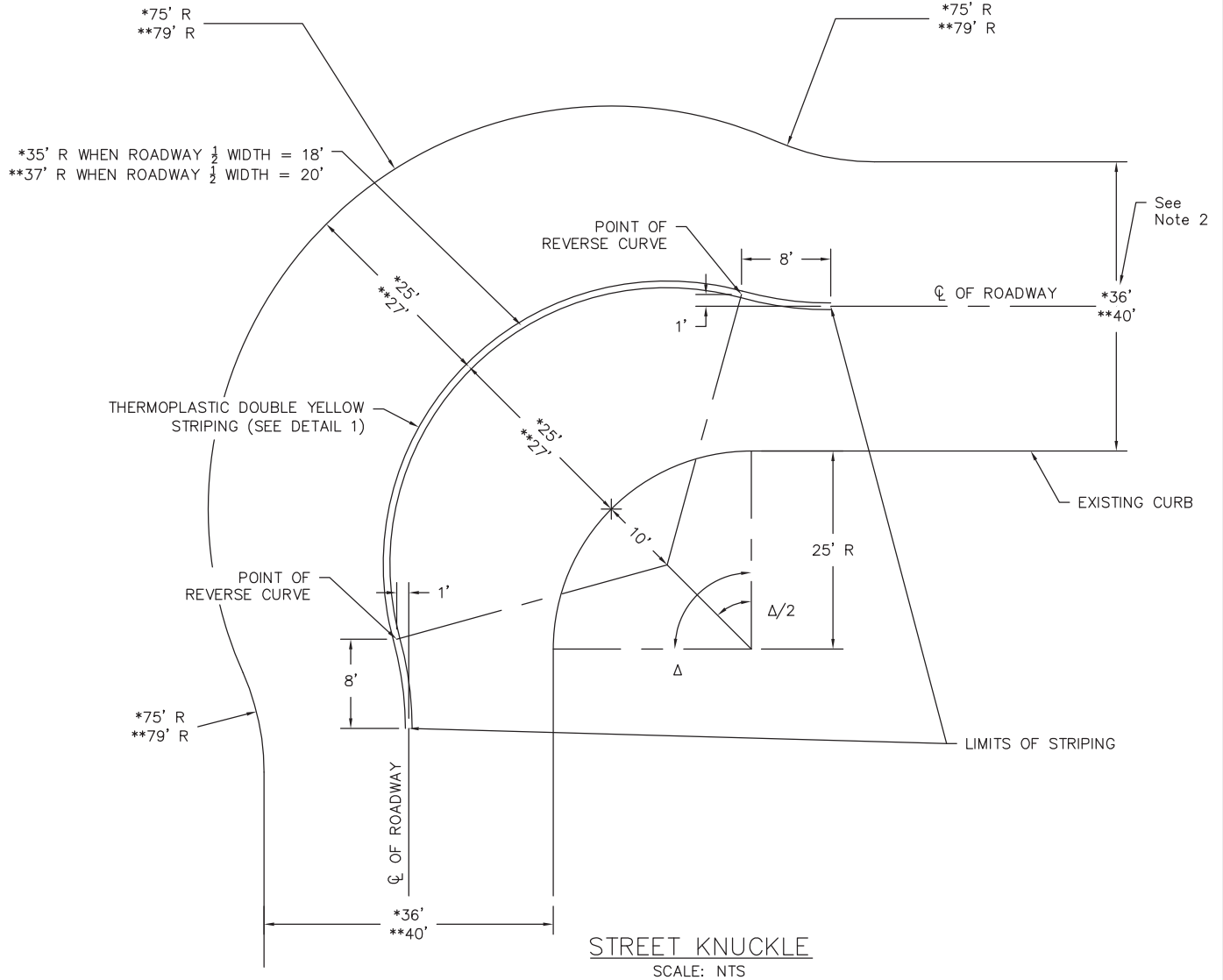

**STREET KNUCKLE**  
SCALE: NTS

**NOTES**

1. THIS STRIPING TREATMENT SHALL BE USED ONLY AT LOCATIONS APPROVED BY CITY ENGINEER.
2. "\*" DENOTES DIMENSIONS FOR LOCAL RESIDENTIAL STREET. "\*\*\*" DENOTES DIMENSIONS FOR MINOR COLLECTOR RESIDENTIAL STREET.

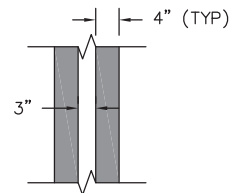

1  
—  
CENTER LINE STRIPING DETAIL

APPROVED  3/8/23  
DATE

DRAFT

 CITY OF PITTSBURGH	NO.	DATE	REVISION	DRAWN BY:	AW	STANDARD DETAIL  STREET KNUCKLE	SHEET 1 OF 1  T-4
	1	2019-01-11	CENTERLINE STRIPING	CHECKED BY:	MK		
				DATE:	2019-01-11		
				SCALE:	NTS		

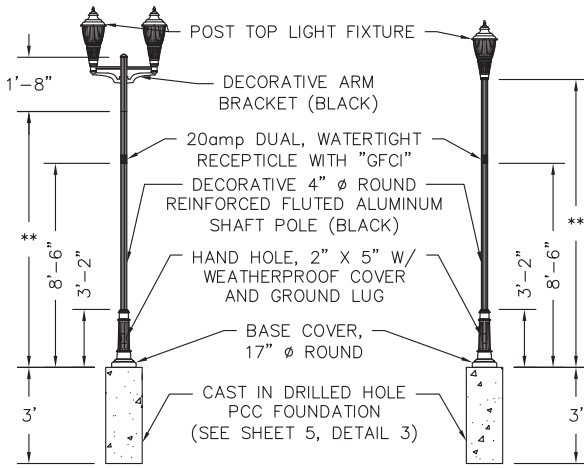

**DECORATIVE LIGHTING**  
TWIN FIXTURE AND SINGLE FIXTURE

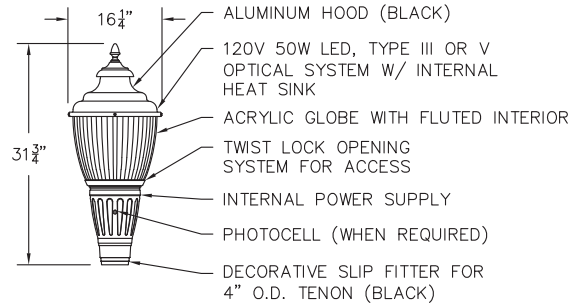

**DECORATIVE "ACORN" LIGHT FIXTURE**  
("CYCLONE LIGHTING" PRESTIGE SERIES POST TOP SHOWN)

**NOTES**

1. ALL POLE HARDWARE NUTS/BOLTS/SCREWS SHALL BE STAINLESS STEEL. FOUNDATION MOUNTING BOLTS/NUTS/WASHERS SHALL BE GALVANIZED.
2. A No. 5 PULLBOX SHALL BE INSTALLED AT EACH LIGHT POLE. PULLBOX LID SHALL HAVE "LIGHTING" STAMPED IN LID.
3. A TWIST LOCK PHOTOCELL SHALL BE INSTALLED IN EACH FIXTURE FOR UN-METERED ELECTRICAL SERVICE INSTALLATIONS.
4. A TWIST LOCK PHOTOCELL SHALL BE INSTALLED IN SERVICE ASSEMBLY FOR METERED ELECTRICAL SERVICE INSTALLATIONS.
5. EACH LIGHT FIXTURE SHALL BE FUSED.
6. CITY-APPROVED DECORATIVE LIGHTING PARTS (OR APPROVED EQUALS) TO BE USED. SEE TABLE 1 FOR LIST OF CITY-APPROVED LIGHTING PARTS. SEE SHEET 6 FOR LIGHTING PARTS SPECIFICATIONS.
7. STEEL TENON BASE ANCHORAGE SHALL BE USED IN TWIN-FIXTURE DECORATIVE LIGHTING POLE WITH POLE HEIGHT GREATER THAN 10' AND/OR WITH BANNER ATTACHED.

TABLE 1: CITY-APPROVED DECORATIVE LIGHTING PARTS		
POST TOP LIGHT FIXTURE	WITHIN "OLD TOWN" BOUNDARY*	"CYCLONE LIGHTING" (PRESTIGE SERIES) CY13T4-VS3ARP-5-50W-3K-120-EV1-DCP-F2AP-PTDR-SQ-CP1-BK-TX
	OUTSIDE "OLD TOWN" BOUNDARY*	"CYCLONE LIGHTING" (PRESTIGE SERIES) CY13T4-VS3AR-5-50W-4K-120-EV1-DCP-F2AP-PTDR-SQ-CP1-BK-TX
POLE	SINGLE FIXTURE	"CYCLONE LIGHTING" PD12-**-GFC2-BK-TX
	TWIN FIXTURE	"CYCLONE LIGHTING" PD12-**-T12-GFC2-BK-TX
MOUNTING ARM BRACKET	TWIN FIXTURE	"CYCLONE LIGHTING" CP2408-C2-T12-BK-TX
BASE COVER		"CYCLONE LIGHTING" BD41-BK-TX
BANNER BRACKET		"CYCLONE LIGHTING" BA2-4-24-A-P-D2-BK-TX

\* "OLD TOWN" BOUNDARY: ALL STREETS (BOTH SIDES) WITHIN THE PERIMETER OF AND INCLUDING; BLACK DIAMOND STREET, E. THIRD STREET, CUMBERLAND STREET AND E. TENTH STREET.

\*\* POLE HEIGHT TO BE DETERMINED BY ENGINEER

APPROVED

3/8/23

DATE

DRAFT



NO.	DATE	REVISION	DRAWN BY:
1	2019-01-11	PARTS LIST	TJM
			CHECKED BY: MK
			DATE: 2019-01-11
			SCALE: NTS

STANDARD DETAIL  
DECORATIVE STREET LIGHTING

SHEET 1 OF 6

T-5

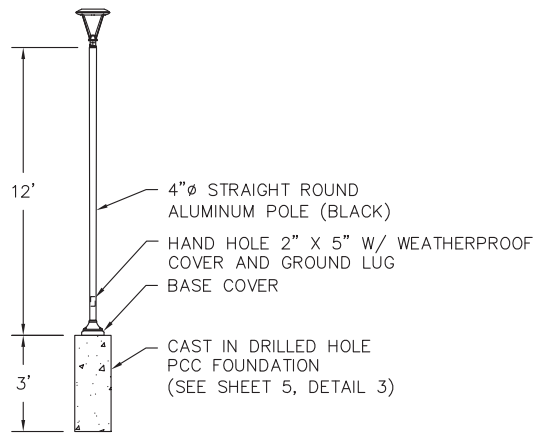

PARK/PATHWAY LIGHTING  
SINGLE FIXTURE

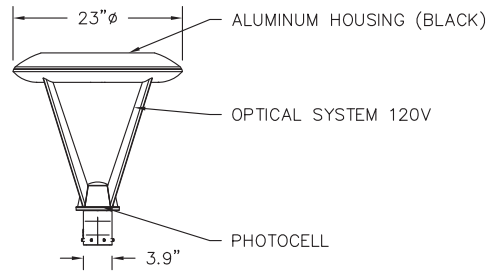

PARK/PATHWAY LIGHT FIXTURE  
("CREE" EDGE SERIES LED SHOWN)

NOTES

1. ALL POLE HARDWARE NUTS/BOLTS/SCREWS SHALL BE STAINLESS STEEL. FOUNDATION MOUNTING BOLTS/NUTS/WASHERS SHALL BE GALVANIZED.
2. A No. 5 PULLBOX SHALL BE INSTALLED AT EACH LIGHT POLE. PULLBOX LID SHALL HAVE "LIGHTING" STAMPED IN LID.
3. A PHOTOCELL SHALL BE INSTALLED IN EACH FIXTURE FOR UN-METERED ELECTRICAL SERVICE INSTALLATIONS.
4. A PHOTOCELL SHALL BE INSTALLED IN SERVICE ASSEMBLY FOR METERED ELECTRICAL SERVICE INSTALLATIONS.
5. EACH LIGHT FIXTURE SHALL BE FUSED.
6. CITY-APPROVED PARK/PATHWAY LIGHTING PARTS (OR APPROVED EQUALS) TO BE USED. SEE TABLE 2 FOR LIST OF CITY-APPROVED LIGHTING PARTS. SEE SHEET 6 FOR LIGHTING PARTS SPECIFICATIONS.

TABLE 2: CITY-APPROVED PARK/PATHWAY LIGHTING PARTS	
LIGHT FIXTURE	"CREE" (EDGE SERIES) ARE-EDR-5M-R3-06-E-UL-BK-40K-525-P
POLE	"CYCLONE LIGHTING" PA40-12-TN32-BK-TX-R30
BASE COVER	"CYCLONE LIGHTING" BD11-BK-TX

APPROVED

3/8/23

DATE

DRAFT



CITY OF PITTSBURGH

NO.	DATE	REVISION	DRAWN BY:	TJM
1	2019-01-11	PARTS LIST	CHECKED BY:	MK
			DATE:	2019-01-11
			SCALE:	NTS

STANDARD DETAIL

PARK/PATHWAY LIGHTING

SHEET 2 OF 6

T-5



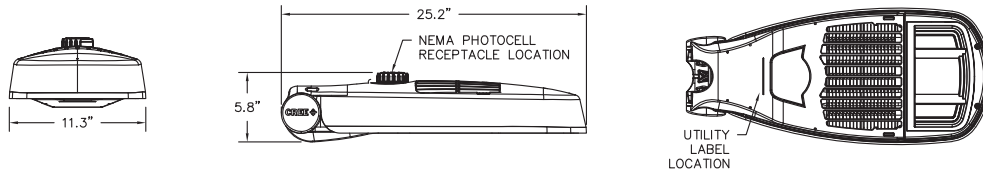

STANDARD COBRA HEAD STREET LIGHT FIXTURE  
("CREE" RSW SERIES LED SHOWN)

NOTES

1. ALL POLE HARDWARE NUTS/BOLTS/SCREWS SHALL BE STAINLESS STEEL. MOUNTING BOLTS/NUTS SHALL BE GALVANIZED.
2. A PULLBOX SHALL BE INSTALLED AT EACH LIGHT POLE.
3. A PHOTOCELL SHALL BE INSTALLED ON EACH FIXTURE.
4. EACH LIGHT FIXTURE SHALL BE FUSED.
5. CONDUIT SHALL HAVE A MINIMUM COVER OF 24 INCHES.
6. USE 8' LUMINAIRE ARM FOR ROADWAYS LESS THAN 40' IN WIDTH AND 15' LUMINAIRE ARM FOR ROADWAYS 40' OR MORE IN WIDTH.
7. A PHOTOCELL SHALL BE INSTALLED IN EACH FIXTURE FOR UN-METERED ELECTRICAL SERVICE INSTALLATIONS.
8. A PHOTOCELL SHALL BE INSTALLED IN SERVICE ASSEMBLY FOR METERED ELECTRICAL SERVICE INSTALLATIONS.
9. CITY-APPROVED STANDARD STREET LIGHTING PARTS (OR APPROVED EQUALS) TO BE USED. SEE TABLE 3 FOR LIST OF CITY-APPROVED LIGHTING PARTS. SEE SHEET 6 FOR LIGHTING PARTS SPECIFICATIONS.

TABLE 3: CITY-APPROVED STANDARD STREET LIGHTING PARTS	
LIGHT FIXTURE	"CREE" (RSW SERIES, MEDIUM) RSWL-A-HT-3ME-14L-40K7-UL-GY-N-Q
POLE	"HAPCO" ALUMINUM POLE AND LUMINAIRE ARM (SEE SHEET 4)

APPROVED \_\_\_\_\_

**3/8/23**

DRAFT

DATE



CITY OF PITTSBURGH

NO.	DATE	REVISION	DRAWN BY:	AW
1	2019-01-11	PARTS LIST	CHECKED BY:	MK
			DATE:	2019-01-11
			SCALE:	NTS

STANDARD DETAIL

STANDARD STREET LIGHTING

SHEET 3 OF 6

T-5

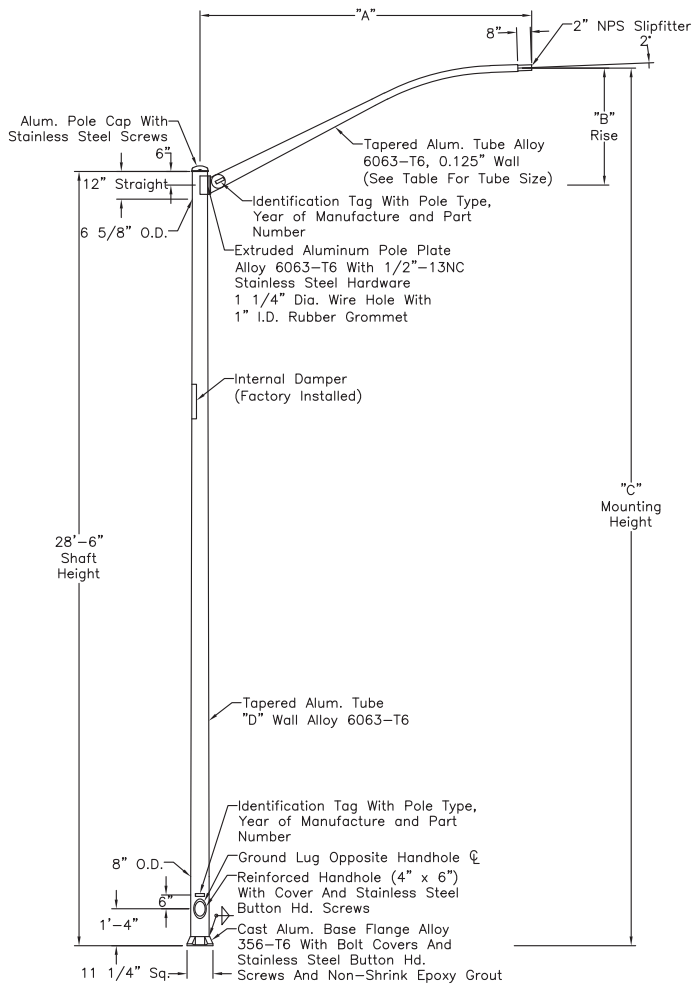

**POLE AND LUMINAIRE ARM**  
("HAPCO" B101150 SHOWN)

Item No.	"A"	"B"	Bracket Member Size	"C"	"D"
101150-008	8"	2'-6"	5" x 3" x .156" Wall	32'-0"	.188"
101150-015	15"	4'-9"	6" x 3" x .188" Wall	34'-3"	.250"

**LUMINAIRE ARM TABLE**

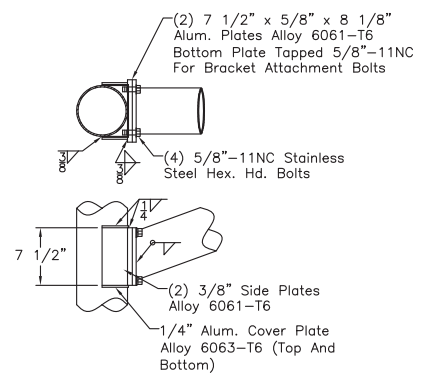

**BRACKET ATTACHMENT DETAIL**

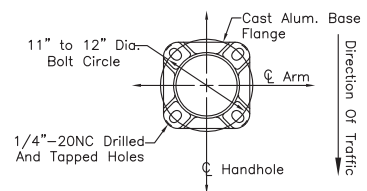

**BASE PLATE DETAIL**

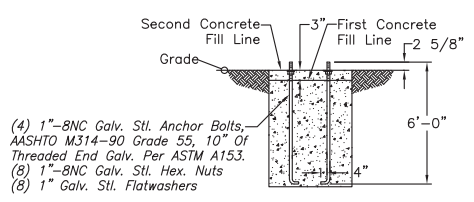

- (4) 1"-8NC Galv. Stl. Anchor Bolts, AASHTO M314-90 Grade 55, 10" Of Threaded End Galv. Per ASTM A153.
- (8) 1"-8NC Galv. Stl. Hex. Nuts
- (8) 1" Galv. Stl. Flatwashers

**FOUNDATION DETAIL**

*[Handwritten Signature]*

APPROVED

3/8/23

DRAFT



NO.	DATE	REVISION	DRAWN BY:	AW
1	2019-01-11	PARTS LIST	CHECKED BY:	MK
			DATE:	2019-01-11
			SCALE:	NTS

STANDARD DETAIL  
STANDARD STREET LIGHTING

DATE  
SHEET 4 OF 6  
T-5

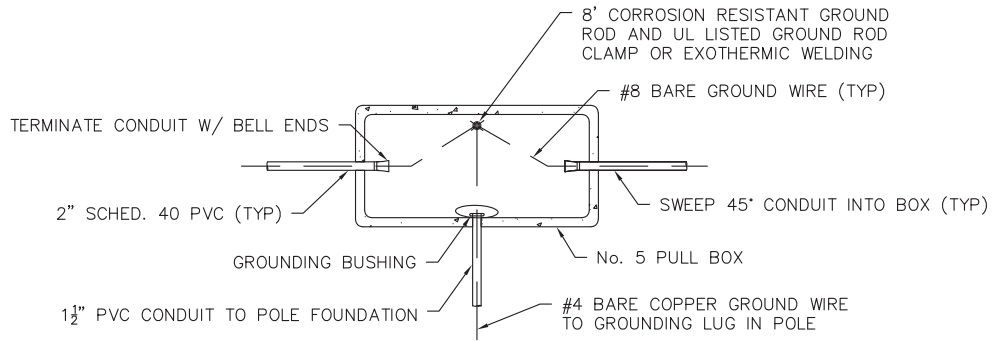

1 PULLBOX INSTALLATION  
FOR ALL STREET LIGHTING

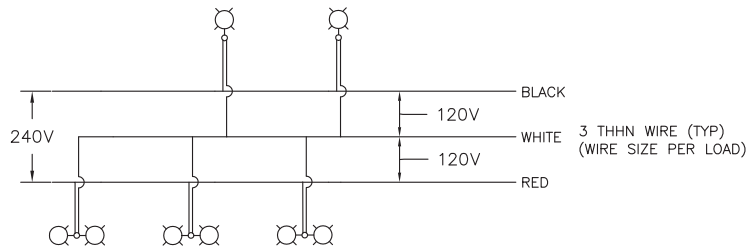

2 WIRING DIAGRAM  
FOR CIRCUITS W/ STANDARD STREET LIGHTING  
120/240 VOLT ELECTRIC SERVICE

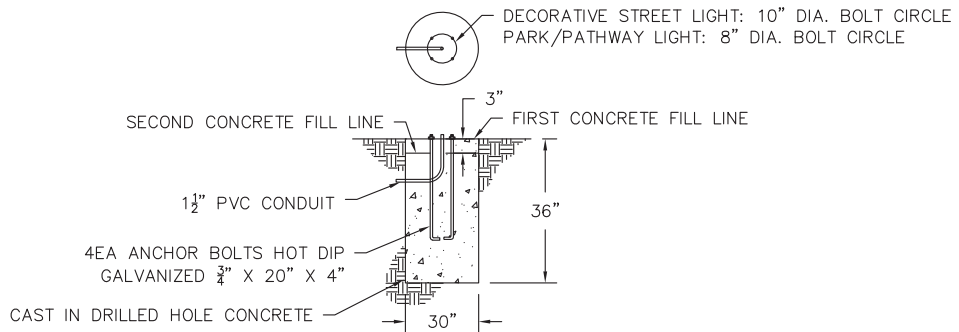

3 STREET LIGHT FOUNDATION  
FOR DECORATIVE AND PARK/PATHWAY LIGHTING

APPROVED

3/8/23

DATE

DRAFT



CITY OF  
PITTSBURG

NO.	DATE	REVISION	DRAWN BY:	TJM
1	2019-01-11	PARTS LIST	CHECKED BY:	MK
			DATE:	2019-01-11
			SCALE:	NTS

STANDARD DETAIL

LIGHTING DETAILS

SHEET 5 OF 6

T-5

DECORATIVE LIGHTING PARTS:

POST TOP LIGHT FIXTURE:

CY13T4 "CYCLONE LIGHTING" PRESTIGE SERIES POST TOP, ALUMINUM HOOD  
 -VS3ARP GLOBE: ACRYLIC (A), RIBBED (R), POND (P)  
 -SKY-5 OPTICS: TYPE V (5)  
 -50W WATTAGE: 50W  
 -3K / 4K CORRELATED COLOR TEMPERATURE (CCT), WITHIN OLD TOWN: 3,000K (3K) OUTSIDE OLD TOWN: 4,000K (4K)  
 -120 / 240 VOLTAGE: 120V OR 240V  
 -EV1 FITTER STYLE  
 -DCP OPTION: CUPOLA, SAME COLOR AS LUMINAIRE  
 -F2AP FINIAL STYLE  
 -PTDR OPTION: DIMMABLE (7-PIN) PHOTOCELL RECEPTACLE  
 -SQ-CP1 OPTION: SQUARE HEAD BOLTS  
 -BK-TX HOUSING COLOR: BLACK, TEXTURED POWDER COAT

MOUNTING ARM BRACKET: (FOR TWIN-FIXTURE ONLY)

CP2408 "CYCLONE LIGHTING" TWIN-FIXTURE MOUNTING ARM, ALUMINUM, 4" Ø TENON FOR LUMINAIRES CONFIGURATION: DOUBLE FIXTURES AT 180°  
 -C2 OPTION: MOUNTING ATTACHMENT FOR 4" Ø FLUTED POLE  
 -BK-TX COLOR: BLACK, TEXTURED POWDER COAT

POLE: (SEE NOTE 1)

PD12 "CYCLONE LIGHTING" POLE, 4" Ø FLUTED, ALUMINUM  
 -10 - 16 HEIGHT (IN FEET)  
 -TB4 ANCHORAGE: STEEL TENON BASE, 4' TALL (SEE NOTE 2)  
 -T12 OPTION: (FOR TWIN-FIXTURE ONLY) MOUNTING ATTACHMENT FOR MOUNTING ARM BRACKET  
 -GFIC2 OPTION: DUPLEX RECEPTACLE, GROUND FAULT CURRENT INTERRUPTER, 125 VAC (20A)  
 -BK-TX COLOR: BLACK, TEXTURED POWDER COAT

BASE COVER:

BD41 "CYCLONE LIGHTING" BASE COVER, ALUMINUM, 17" Ø, 39.5" HEIGHT  
 -BK-TX COLOR: BLACK, TEXTURED POWDER COAT

BANNER BRACKET: (OPTIONAL)

BA2 "CYCLONE LIGHTING" BANNER ARMS, ALUMINUM, 1" Ø RODS, REMOVABLE  
 -4 POLE DIAMETER (IN INCHES)  
 -24 BANNER LENGTH (IN INCHES)  
 -A-P FINIAL: ALUMINUM (A), PAINTED (P)  
 -D2 ARM CONFIGURATION: DOUBLE BANNER, TOP AND BOTTOM ARMS  
 -BK-TX COLOR: BLACK, TEXTURED POWDER COAT

NOTES

- IF POLE ANCHORAGE IS NOT SPECIFIED, ANCHORAGE SHALL BE ANCHOR PLATE.
- STEEL TENON BASE (-TB4) ANCHORAGE SHALL BE USED IN TWIN-FIXTURE DECORATIVE LIGHTING POLE WITH POLE HEIGHT GREATER THAN 10' AND/OR WITH BANNER ATTACHED.

PARK/PATHWAY LIGHTING PARTS:

LIGHT FIXTURE:

ARE-EDR "CREE" EDGE SERIES  
 -5M OPTICS: TYPE V MEDIUM (5M)  
 -R3 MOUNTING: SPIDER, CENTER TENON, 2 3/8" TO 3" O.D.  
 -06 LED COUNT (x10): 60 LEDs (06)  
 -E SERIES  
 -UL VOLTAGE: UNIVERSAL 120-277V  
 -BK COLOR: BLACK  
 -40K COLOR TEMPERATURE: 4,000K  
 -525 DRIVE CURRENT (IN mA)  
 -P OPTION: PHOTOCELL

POLE: (SEE NOTE 1)

PA40 "CYCLONE LIGHTING" POLE, 4" Ø STRAIGHT, ALUMINUM  
 -12 HEIGHT (IN FEET)  
 -TN32 OPTION: POST TOP TENON, 3" Ø, 2" HEIGHT  
 -BK-TX COLOR: BLACK, TEXTURED POWDER COAT  
 -R30 REDUCER: 3" Ø

BASE COVER:

BD11 "CYCLONE LIGHTING" BASE COVER, 15" Ø, 9.5" HEIGHT  
 -BK-TX COLOR: BLACK, TEXTURED POWDER COAT

STANDARD STREET LIGHTING PARTS:

LIGHT FIXTURE:

RSWM "CREE" RSW SERIES, MEDIUM VERSION  
 -A MOUNTING: HORIZONTAL TENON  
 -HT OPTICS: TYPE iii MEDIUM (3ME)  
 -3ME LUMEN PACKAGE: 9,050 LUMENS  
 -9L CCT AND CRI: 4,000K (40K), 70 CRI (7)  
 -40K7 VOLTAGE: UNIVERSAL 120-277V  
 -UL COLOR: GRAY (GY)  
 -GY RECEPTACLE: NEMA 7-PIN PHOTOCELL  
 -N OPTION: FIELD-ADJUSTABLE LUMEN OUTPUT  
 -Q

POLE: SEE SHEET 4



APPROVED \_\_\_\_\_

3/8/23

DATE

DRAFT



CITY OF PITTSBURGH

NO.	DATE	REVISION	DRAWN BY:
			CHECKED BY: MK
			DATE: 2019-01-11
			SCALE: NONE

STANDARD DETAIL

LIGHTING PARTS SPECIFICATIONS

SHEET 6 OF 6

T-5

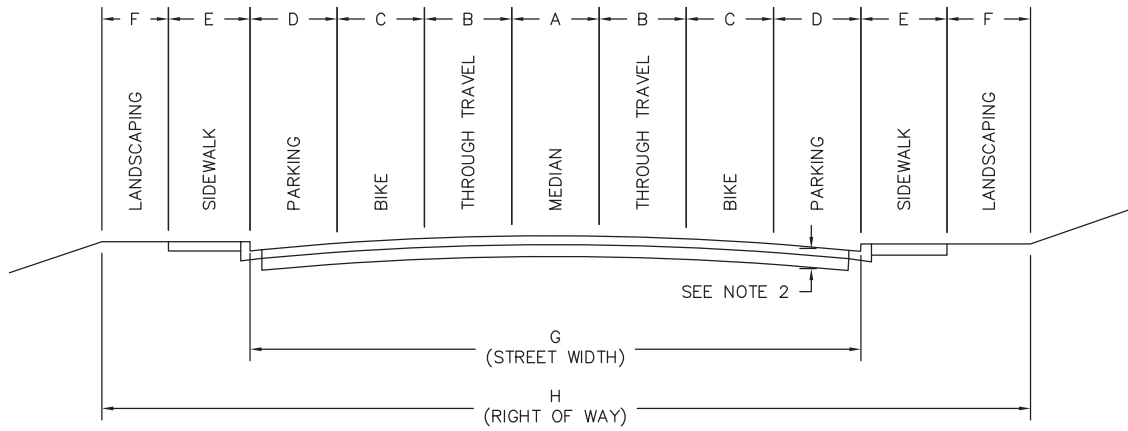

TYPICAL STREET SECTION  
SCALE: NTS

NOTES

1. SEE SHEET 2 FOR WIDTHS.
2. STRUCTURAL SECTION BASED ON R-VALUE. 3" MINIMUM AC DEPTH.

APPROVED \_\_\_\_\_

**3/8/23**

DRAFT

DATE



CITY OF  
PITTSBURG

NO.	DATE	REVISION	DRAWN BY:	JR
			CHECKED BY:	MK
			DATE:	2019-01-11
			SCALE:	NTS

STANDARD DETAIL

TYPICAL STREET SECTION

SHEET 1 OF 2

T-6

Street Classification	ADT <sup>1</sup> (vehicles per day)	Minimum Traffic Index (T.I.)	Minimum Design Speed (mph)	Maximum Grade (%)	Widths (feet)								
					A	B	C	D	E	F	G	H	
					Median Lane <sup>8</sup>	Through Travel Lanes <sup>9</sup>	Bike Lanes/ Shoulders <sup>9</sup>	Parking Lanes <sup>9</sup>	Sidewalks or Landscaping <sup>2,9</sup>	Landscaping or Sidewalks <sup>2,9</sup>	Street <sup>10</sup>	Right-of-Way <sup>11</sup>	
Residential	Private Driveway (serving 2 or more parcels) <sup>3,5</sup>	<40		20	15		7					14	14
	Private Roadway <sup>4,5</sup>	40 to 1000		20	15		10					20	20
	Cul-de-Sac <sup>4</sup>	<200	4.0	20	15		10		8	6		36	48
	Local	< 1000	4.5	30	12		10		8	6		36	48
	Minor Collector	1000 to 3000	6.0	30	11		12		8	6		40	52
	Major Collector (without abutter's rights)	3001 to 5000	7.0	40	9		12	6		5	6	36	58
	Major Collector (with abutter's rights)	3001 to 5000	7.0	40	9	12	12	5	8	6	5	62	84
	Arterial	>5000	8.0	55	7	16	24	8		10	10	80	120
Non-Residential	Local	<1000	7.0	30	8		12		8	10	5	40	70
	Collector	1000 to 5000	8.0	40	8		12	5	9	10	5	52	82
	Major Arterial	>5000	9.5	55	7	16	25	8		10	10	82	122
Hillside	Private Driveway (serving 2 or more parcels) <sup>3,5,6</sup>	<40		20	17		7					14	14
	Private Roadway <sup>4,5,8</sup>	40 to 1000		20	16		10					20	20
	Cul-de-Sac <sup>4,6,7</sup>	<200	4.0	25	15		10		6	5		32	42
	Local <sup>6,7</sup>	< 1000	4.5	25	14		10		6	5		32	42
	Minor Collector <sup>6,7</sup>	1000 to 3000	6.0	30	12		11		7	5		36	46
	Major Collector (without abutter's rights) <sup>6</sup>	3001 to 5000	7.0	30	11		11	5		5	6	32	54
	Major Collector (with abutter's rights) <sup>6,7</sup>	3001 to 5000	7.0	30	11	11	11	4	8	6	5	57	79
	Arterial <sup>6</sup>	>5000	8.0	40	8	16	24	6		5	6	76	98

- (1) Projected Average Daily Traffic. Using current Institute of Transportation Engineer's (ITE) trip generation rates.
- (2) Sidewalk located adjacent to curb when ADT ≤ 5000 vpd or where abutter's rights have been relinquished, otherwise landscaping located between curb and sidewalk.
- (3) Maximum length of Private Driveway = 150 feet.
- (4) Maximum length of Public or Private Cul-de-Sac/Dead End street = 700 feet.
- (5) Private access to multiple parcels must be approved by the City Engineer
- (6) Hillside Development Standards apply above 500 foot elevation.
- (7) Parking lane and sidewalk may be eliminated on one side of street where grading does not allow development.
- (8) 11' or 12' = painted median; 16' = raised median
- (9) Both sides
- (10) Face of curb / Edge of pavement to Face of curb / Edge of pavement. A+2B+2C+2D
- (11) P.U.E.'s and slope grading not included. A+2B+2C+2D+2E+2F

3/8/23



APPROVED

DRAFT	REVISION	DATE	DRAWN BY:	CHECKED BY:	DATE:	SCALE:
	1	2019-01-11	MK	MK	2019-01-11	NONE
CITY OF PITTSBURGH		STANDARD DETAIL		TYPICAL STREET SECTION		DATE
				SHEET 2 OF 2		T-6



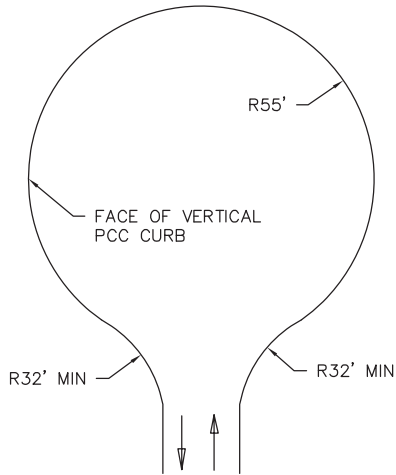

CUL-DE-SAC  
SCALE: NTS

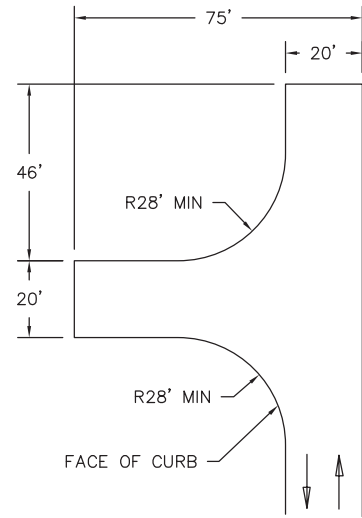

SHUNT  
SCALE: NTS

NOTES

1. CUL-DE-SAC MUST BE USED UNLESS T-TURN OR SHUNT IS APPROVED BY THE CITY ENGINEER

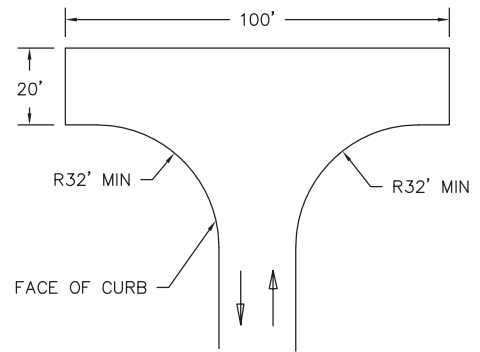

T-TURN  
SCALE: NTS

APPROVED

3/8/23

DRAFT

DATE



CITY OF  
PITTSBURG

NO.	DATE	REVISION	DRAWN BY:	JR
			CHECKED BY:	MK
			DATE:	2019-01-11
			SCALE:	NTS

STANDARD DETAIL

CUL-DE-SAC AND TURNAROUNDS

SHEET 1 OF 1

T-7

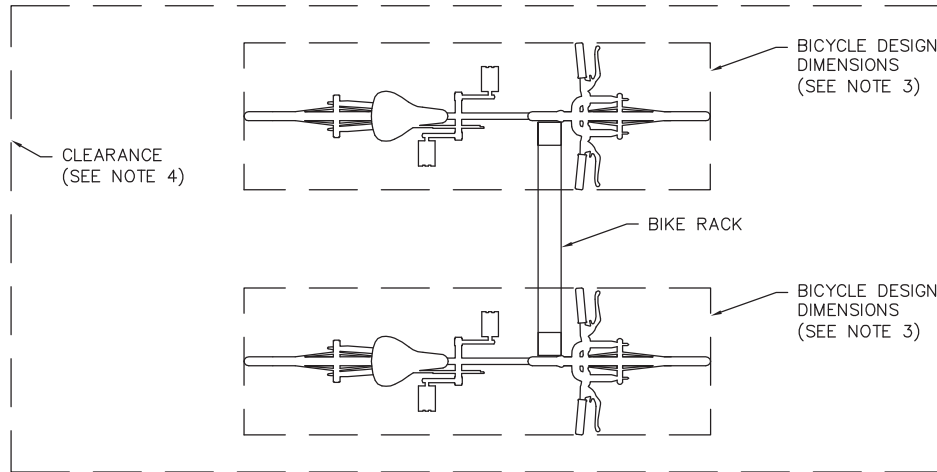
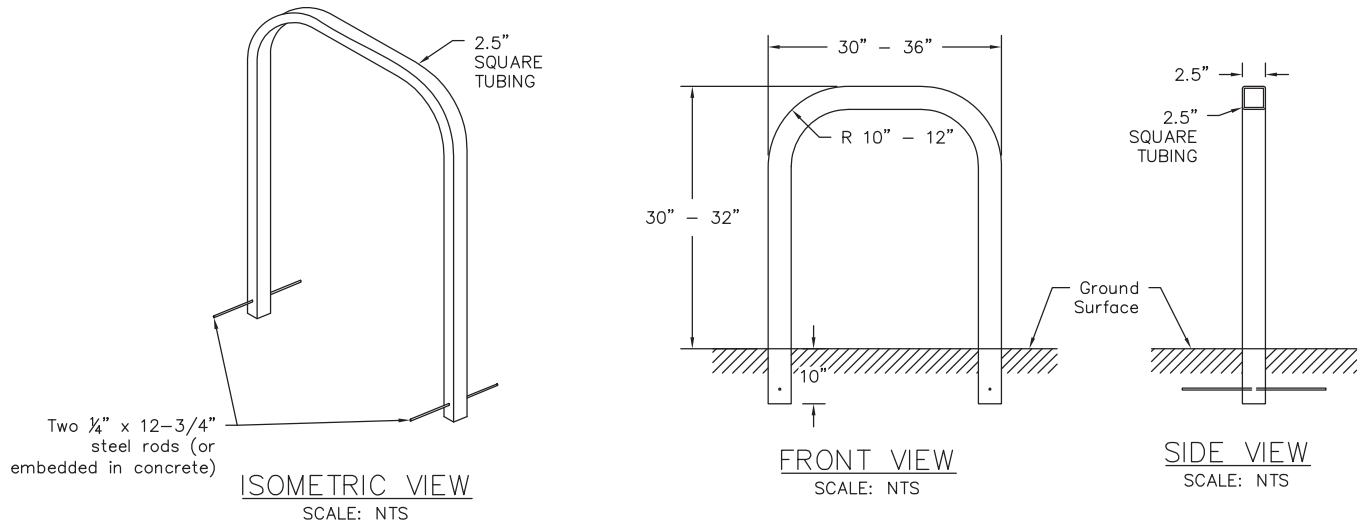

**INVERTED-U BIKE RACK**  
TWO BICYCLES PER RACK

**NOTES**

1. BIKE RACK TO BE GALVANIZED, PAINTED, OR POWDER COATED TO MATCH SURROUNDING IMPROVEMENTS.
2. BIKE RACKS SHOULD BE LOCATED TO MAXIMIZE VISIBILITY, NOT OBSTRUCT PEDESTRIAN TRAFFIC OR FIRE HYDRANTS, AND AS CLOSE AS PRACTICAL TO BUILDING ENTRANCES.
3. BICYCLE DESIGN DIMENSIONS ARE 72" X 24" IN PLAN VIEW. ADDITIONAL CLEARANCE REQUIRED FOR MANEUVERING IS 48" LONGITUDINALLY AND 24" TRANSVERSELY.
4. FOOTPRINT OF BIKE RACK WITH TWO BICYCLES AND REQUIRED CLEARANCES IS 120" X 72".
5. MINIMUM SPACING BETWEEN BIKE RACKS IS 30".
6. MINIMUM STREET SETBACK IS 36".

APPROVED

3/8/23

DATE

DRAFT



CITY OF PITTSBURGH

NO.	DATE	REVISION	DRAWN BY:	AW
1	2019-01-11	UPDATED STD DETAIL	CHECKED BY:	MK
			DATE:	2019-01-11
			SCALE:	NTS

STANDARD DETAIL

BIKE RACK

SHEET 1 OF 1

T-9



## TEMPORARY TRAFFIC CONTROL PLAN (TTCP) CHECKLIST

No traffic control may be implemented on City streets without City approval.

This checklist is provided to assist Developers and Contractors in developing acceptable Temporary Traffic Control Plans (TTCP's) for encroachments onto City right-of-way. Please refer to the California Manual of Uniform Traffic Control Devices (MUTCD), Part 6: Temporary Traffic Control, for basic information on preparing TTCP's and typical TTCP examples ([www.dot.ca.gov/hq/traffops/signtech/mutcdsupp/ca\\_mutcd.htm](http://www.dot.ca.gov/hq/traffops/signtech/mutcdsupp/ca_mutcd.htm)).

Contractor is responsible for inspecting any approved traffic detour routes to insure adequate horizontal and vertical clearances are maintained from obstructions (e.g., poles and overhanging tree limbs).

### Lane Closures

- Except for emergencies or unless otherwise specified:
  - No lane closures will be allowed on weekdays from 6:00 AM to 8:30 AM, or from 3:30 PM to 6:00 PM.
  - Two-lane closures and lane closures with reversible control will not be allowed on weekdays before 9:00 AM, or after 3:00 PM.

### Road Closures

- Except for emergencies or unless otherwise specified:
- Full road closures may only be used when no other types of temporary traffic control are feasible for the work involved.
- Detour routes and notification plans must be submitted to the City at least two weeks in advance.
- The road closure(s) must be limited in duration and area as practicable.

### Construction Activity

- Show the exact location of the work zone and how it is to be protected (e.g., cones, barricades, k-rail) during construction.
- Show construction schedule, work hours, and all times TTCP will be in effect.
- Include details on construction activity and equipment being used within street right-of-way. Specify how the work area will be protected at night (e.g., trench plates).
- If work is to be done in phases, submit separate TTCP's for each phase of work.
- All detour signs must be removed or covered when detour is not in effect.
- Traffic Control Devices
- Every roadside sign on the TTCP should include the MUTCD sign number, dimension and description.

APPROVED \_\_\_\_\_



**3/8/23**

DRAFT

DATE

 CITY OF PITTSBURGH	NO.	DATE	REVISION	DRAWN BY:	STANDARD DETAIL  TEMPORARY TRAFFIC CONTROL PLAN CHECKLIST	SHEET 1 OF 2  T-10
				CHECKED BY: MK		
				DATE: 2019-01-11		
				SCALE: NONE		

**TEMPORARY TRAFFIC CONTROL PLAN (TTCP) CHECKLIST (CONT'D)**

- A Flashing Arrow Sign/Board (FAS) must be used for all lane/street closures, and for lane/street detours on the following streets. (Include size, panel display and exact location on the TTCP).
  - Railroad Avenue/Kirker Pass Road
  - Bailey Road
  - Somersville Road
  - Loveridge Road
  - West/East Leland Road
  - Buchanan Road
  - Power Avenue
  - San Marco Boulevard
  - Harbor Street
  - North Parkside Drive
  - Willow Pass Road
  - Pittsburg–Antioch Highway
  - California Avenue
  - Century Boulevard
  - West/East Tenth Street
- Flaggers should be identified where required and their position shown on the TTCP.
- Show dimensions and locations of all channelizing devices, warning lights, flag trees, and portable barriers on the TTCP. All devices must comply with California MUTCD.

Traffic Signal Operation and Equipment

- Include location of all traffic signals and traffic signal detection devices within the traffic control area.
- If special signal timing is required in the TTCP, specify all changes and their effects. This includes changing signal operations to flashing red, recall or fixed time.

Pedestrian/Bicycle Safety

- Pedestrians and bicyclists must have a safe route to walk/ride through and/or around the work area wherever practicable.
- Show all pedestrian/bicycle entries, detours, paths and exits on the TTCP.
- Clearly show description and location of all traffic control devices, including fences and barricades, within the pedestrian’s/bicyclists safe route to walk/ride on the TTCP.

Parking Restrictions

- Parking restrictions must be clearly posted a minimum of 48 hours before work begins. Their implementation will be at the expense of the contractor/developer.
- All legal parking areas must be maintained unless signs are posted. Access to legally parked vehicles’ doors and storage areas must also be maintained.
- Parking restrictions must be limited in time as practicable. Restrictions may only be used when there are no other types of traffic control feasible for the work involved, and parking demand can be reasonably accommodated.

Please contact the Traffic Engineering Division at (925) 252–4930 for any questions related to TTCP’s, including closures, traffic signal operations, and temporary “No Parking” signs.

Please allow five (5) working days for the City to review the TTCP. Once the TTCP is approved it must be available for inspection on–site at all times. Should City staff on the job site find potential hazards with an approved TTCP, City may require changes to the TTCP to maintain safety.

APPROVED  3/8/23  
DATE

DRAFT

 CITY OF PITTSBURG	NO.	DATE	REVISION	DRAWN BY:	STANDARD DETAIL  TEMPORARY TRAFFIC CONTROL PLAN CHECKLIST	SHEET 2 OF 2	
	1	2019–01–11	ADDED SAN MARCO BLVD	CHECKED BY: MK		DATE: 2019–01–11	T–10
				DATE: 2019–01–11			
				SCALE: NONE			

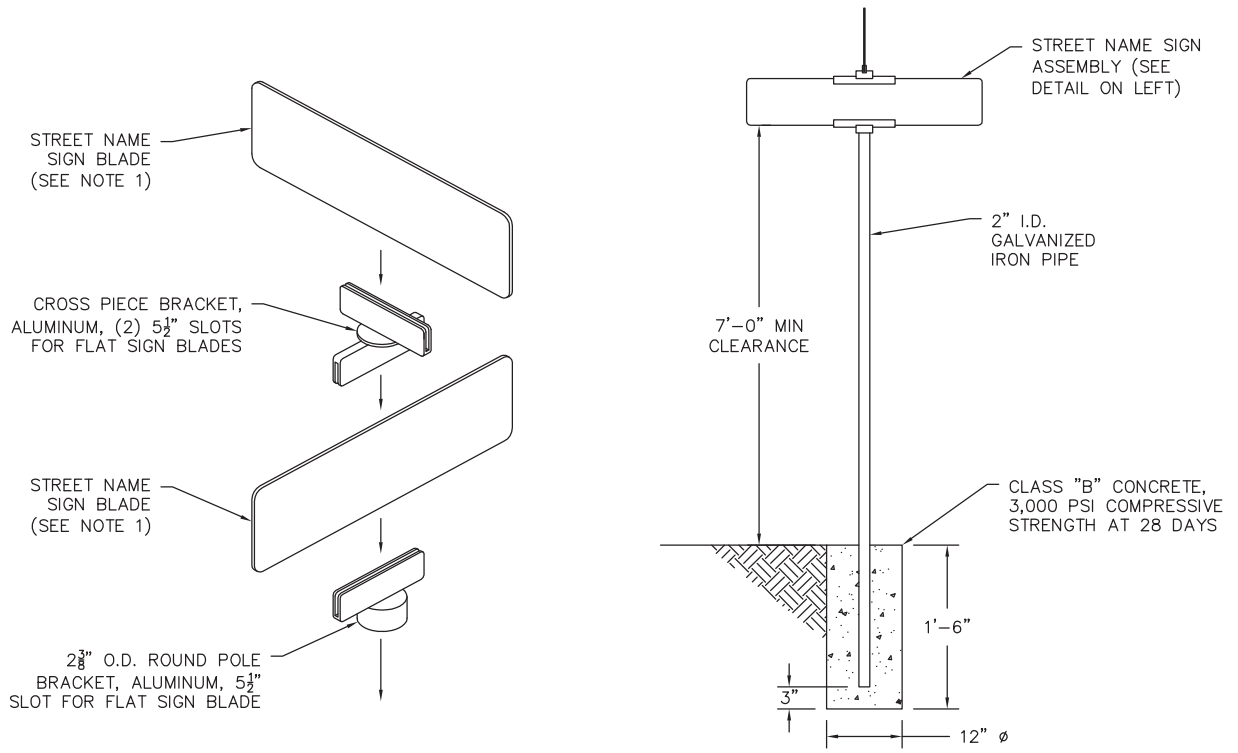

STREET NAME SIGN ASSEMBLY

POLE & FOOTING DETAIL

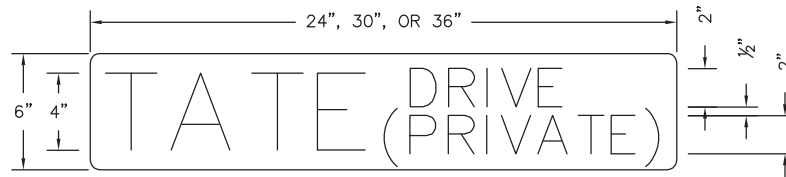

PRIVATE STREET LETTERING

(SEE NOTE 4)

NOTES

1. STREET NAME SIGN BLADE SHALL BE MADE ON FLAT ALUMINUM PLATE WITH A THICKNESS OF 0.080" AND DOUBLE-FACED. SIGN FIELD TO BE GREEN, HIGH-INTENSITY PRISMATIC (HIP) SHEETING AND SHALL ALLOW 1" (MIN) MARGIN AROUND LETTERING. LETTERING TO BE 4" UPPERCASE, WHITE, GOTHIC (SEE NOTE 4).
2. CITY-APPROVED STREET NAME SIGN PARTS (OR APPROVED EQUALS) TO BE USED. SEE TABLE 1 FOR LIST OF CITY-APPROVED PARTS.
3. STANDARDS SHALL BE 2" I.D. GALVANIZED IRON PIPE.
4. LETTERING ON "PRIVATE STREET" SIGNS SHALL HAVE 4" LETTER HEIGHT FOR NAME AND 2" LETTER HEIGHT FOR SUFFIX (LANE, COURT, ETC.) AND THE WORD "PRIVATE". "PRIVATE" SHALL BE PARENTHEZIZED.
5. PROPERTY OWNER(S) ON A "PRIVATE STREET" SHALL BE RESPONSIBLE FOR PROPER MAINTENANCE OF THE PRIVATE STREET SIGN. IT SHALL BE MOUNTED WITHIN THE PRIVATE RIGHT OF WAY.

TABLE 1: CITY-APPROVED STREET NAME SIGN PARTS	
POLE BRACKET	"TAPCO" 2 3/8" OD ROUND POLE BRACKET, 5 1/2" FLAT SLOT, UNPAINTED (P/N: 037-00022)
CROSS PIECE BRACKET	"TAPCO" CROSS PIECE BRACKET, 5 1/2" FLAT SLOT, UNPAINTED (P/N: 037-00021)

APPROVED  DATE 3/8/23

DRAFT

 CITY OF PITTSBURGH	NO.	DATE	REVISION	DRAWN BY: AW	STANDARD DETAIL  STREET NAME SIGN	SHEET 1 OF 1  T-11
				CHECKED BY: MK		
				DATE: 2019-01-11		
				SCALE: NTS		

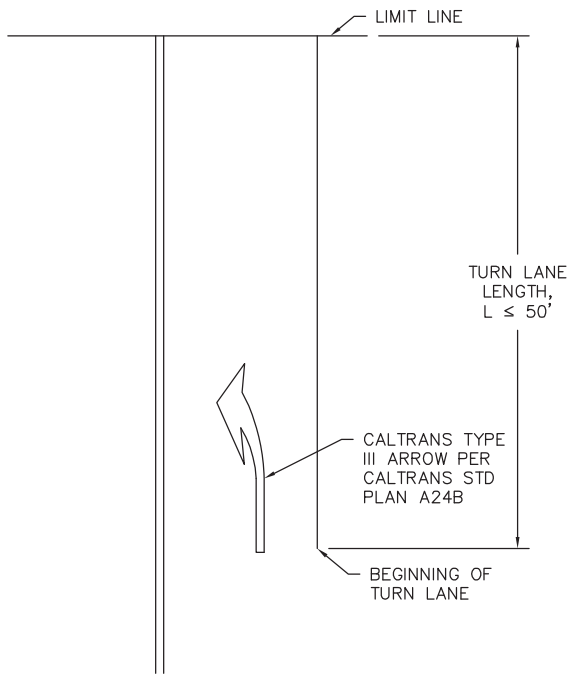

TURN LANE ( $L \leq 50'$ )  
(LEFT TURN LANE SHOWN)

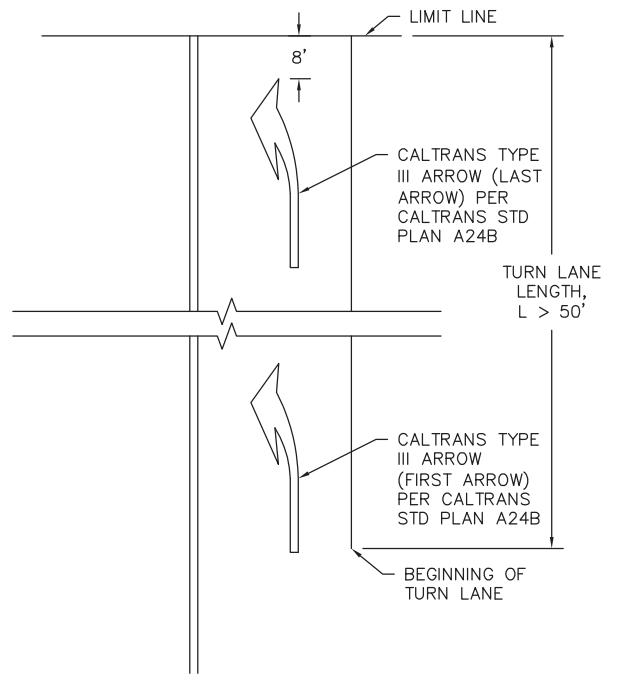

TURN LANE ( $L > 50'$ )  
(LEFT TURN LANE SHOWN)

**NOTES**

1. TURN ARROW PAVEMENT MARKINGS SHALL BE THERMOPLASTIC.
2. SEE TABLE 1 FOR NUMBER OF ARROWS TO BE INSTALLED PER TURN LANE.
3. THE FIRST ARROW SHALL BE PLACED AT THE BEGINNING OF THE TURN LANE. IF APPLICABLE, THE LAST ARROW SHALL BE PLACED 8' BACK FROM THE LIMIT LINE. ANY ADDITIONAL ARROWS SHALL BE SPACED EVENLY BETWEEN THE FIRST ARROW AND LAST ARROW.

TURN LANE LENGTH, L	NUMBER OF TURN ARROWS
1' - 50'	1
51' - 100'	2
101' - 150'	3
151' - 200'	4
...	...
L	roundUp(L/50')

APPROVED

3/8/23

DRAFT

DATE



CITY OF PITTSBURGH

NO.	DATE	REVISION	DRAWN BY:	AW
			CHECKED BY:	MK
			DATE:	2019-01-11
			SCALE:	NTS

STANDARD DETAIL

TURN ARROW LAYOUT

SHEET 1 OF 1

T-12

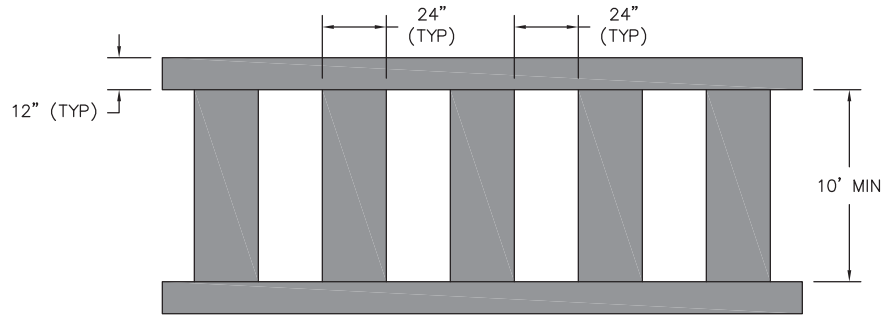

LADDER CROSSWALK

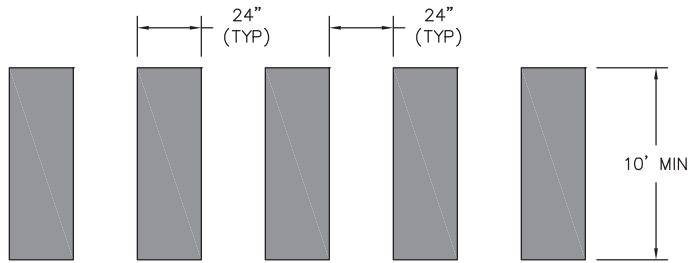

CONTINENTAL CROSSWALK

LEGEND

 THERMOPLASTIC PAVEMENT MARKING

APPROVED 

3/8/23

DRAFT

DATE



CITY OF PITTSBURGH

NO.	DATE	REVISION	DRAWN BY:	AW
			CHECKED BY:	MK
			DATE:	2019-01-11
			SCALE:	NTS

STANDARD DETAIL  
HIGH VISIBILITY CROSSWALKS

SHEET 1 OF 1

T-13

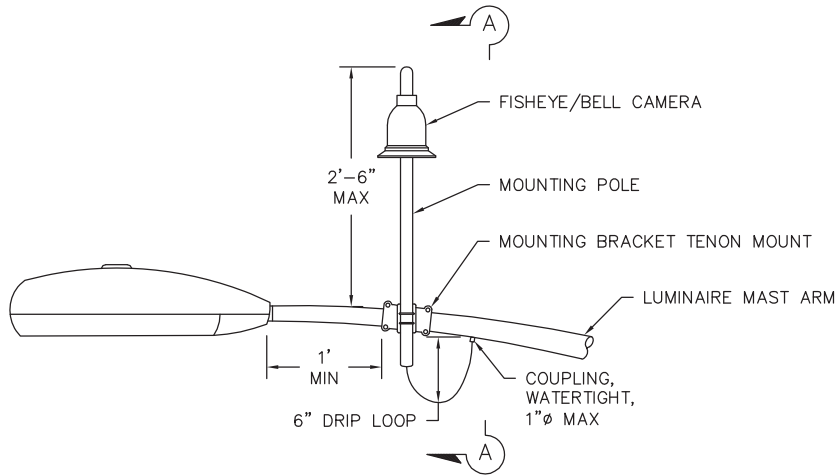

**LUMINAIRE MAST ARM MOUNT**  
("GRIDSMART" BELL CAMERA SHOWN)

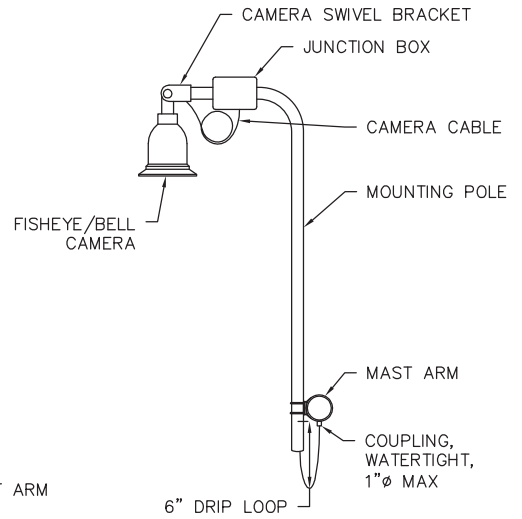

**SECTION A-A**  
("GRIDSMART" BELL CAMERA SHOWN)

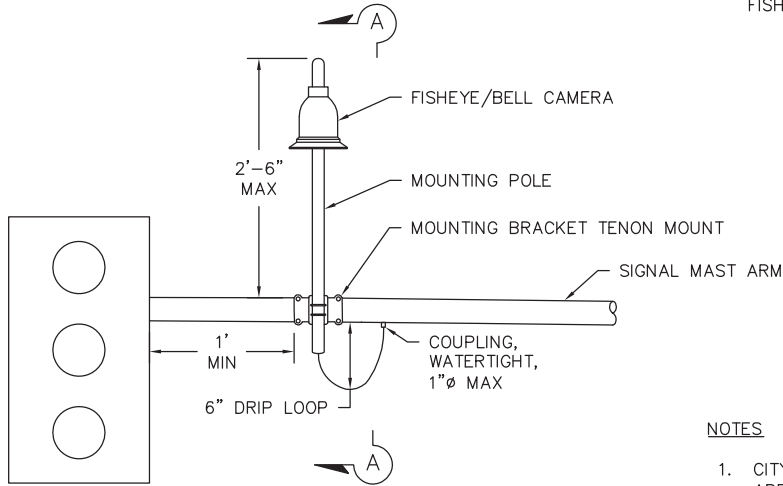

**SIGNAL MAST ARM MOUNT**  
("GRIDSMART" BELL CAMERA SHOWN)

**NOTES**

1. CITY-APPROVED VIDEO DETECTION SYSTEM (OR APPROVED EQUAL) TO BE USED. SEE TABLE 1.
2. VIDEO DETECTION SYSTEM TO BE INSTALLED PER MANUFACTURER SPECIFICATIONS.

**TABLE 1: CITY-APPROVED VIDEO DETECTION SYSTEM PARTS**

CAMERA	"GRIDSMART" FISHEYE CAMERA (P/N: GS-3-CAM)
PROCESSING UNIT	"GRIDSMART" GS2 PROCESSOR (P/N: GS-3-GS2)
CAMERA MOUNTING BRACKET	"GRIDSMART" SWIVEL BRACKET CAMERA MOUNTING HARDWARE W/ JUNCTION BOX & CONNECTOR (P/N: GS-3-SMC)
ARM POLE	"GRIDSMART" CAMERA MOUNTING ARM POLE (90'), 58"/34" (P/N: GS-3-A58/A34)
ARM POLE MOUNT CLAMP	"GRIDSMART" STANDARD TENON MOUNT CLAMP (P/N: GS-3-TEN) "SKYBRACKET" STANDARD TENON MOUNT CLAMP (P/N: SB-TM-SCK) "ASTRO-BRAC" STANDARD TENON MOUNT CLAMP (P/N: AB-3010)
ARM POLE	"GRIDSMART" CAMERA MOUNTING ARM POLE (90'), 58"/34" (P/N: GS-3-A58/A34)

APPROVED

3/8/23

DRAFT

DATE



CITY OF PITTSBURGH

NO.	DATE	REVISION	DRAWN BY:	AW
			CHECKED BY:	MK
			DATE:	2019-01-11
			SCALE:	NTS

STANDARD DETAIL

VIDEO DETECTION SYSTEM

SHEET 1 OF 1

T-14

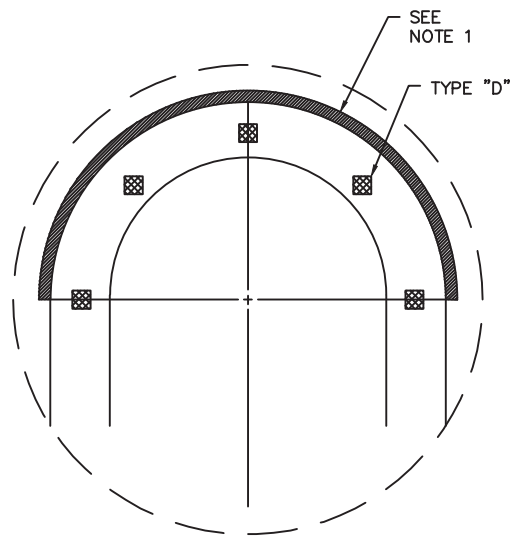
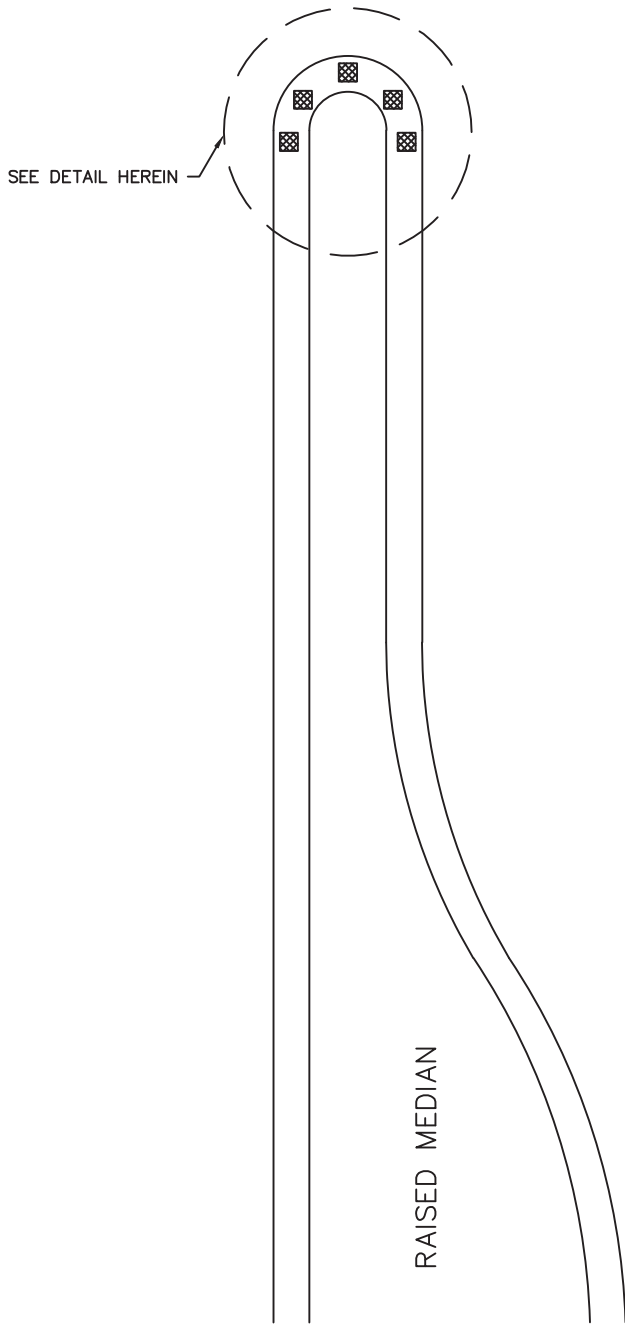

MEDIAN NOSE DETAIL

**NOTES**

1. PAINT MEDIAN NOSE WITH YELLOW TRAFFIC PAINT.
2. INSTALL R4-7 SIGN AND TYPE "N" OBJECT MARKER ON TELES PAR POST. IF MEDIAN IS LESS THAN 2' WIDE, INSTALL FLEXIBLE VERTICAL TYPE "K" MARKER.
3. INSTALL YELLOW REFLECTIVE PAVEMENT MARKERS ON TOP OF SURFACE OF MEDIAN CURB NOSE AT 2' ON CENTER SPACING (MINIMUM 5 MARKERS). PLACE SURFACE MARKER'S REFLECTIVE SURFACE FACING ON COMING TRAFFIC.

**LEGEND**

☒ — TYPE "D" TWO-WAY YELLOW REFLECTIVE MARKER (HIGH INTENSITY)

APPROVED  3/8/23  
DATE

 CITY OF PITTSBURGH	NO.	DATE	REVISION	DRAWN BY: RL	STANDARD DETAIL  RAISED PAVEMENT MARKERS	SHEET 1 OF 1  T-15
				CHECKED BY: SA		
				DATE: 2022-07-05		
				SCALE: NTS		